

THIS DRAWING IS UNPUBLISHED. RELEASED FOR PUBLICATION, 19 .  
 © COPYRIGHT 19 BY AMP INCORPORATED. ALL INTERNATIONAL RIGHTS RESERVED.

LOC		DIST		P		F		ZONE		LTR		REVISIONS		DATE	APPD
DF	XO									G		REV PER 0H14-0112-04	CT	1-14-05	DE

1. PARTS PACKAGED UNASSEMBLED
- △ 6.35 [.250] MAXIMUM PANEL THICKNESS
3. CRIMP TOOL: 69311-1
4. SEE I.S. 1833

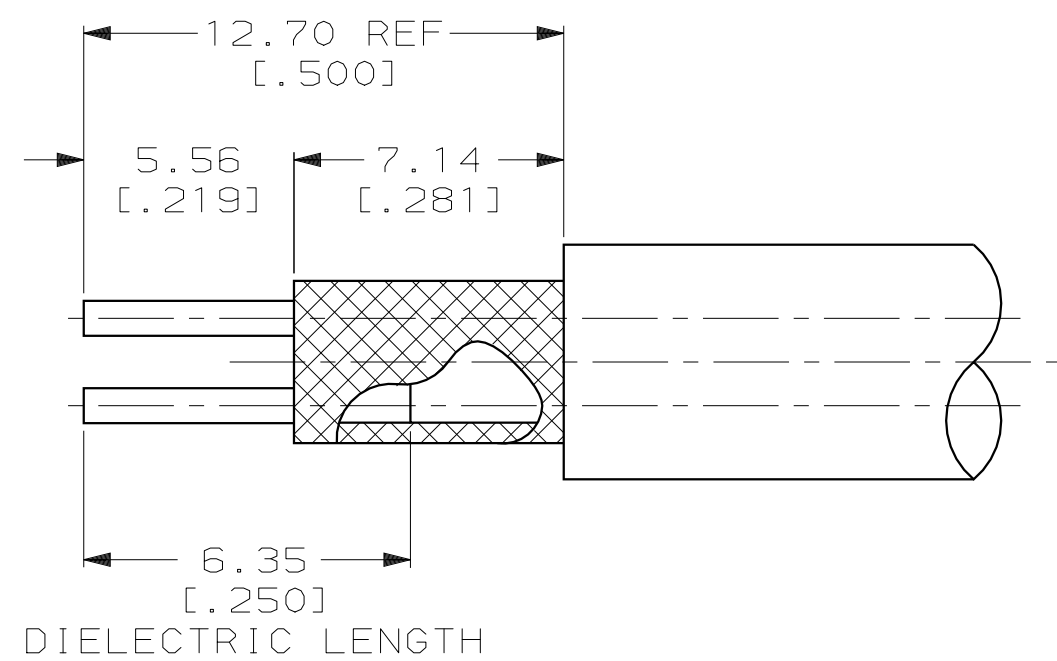

RECOMMENDED STRIP LENGTH

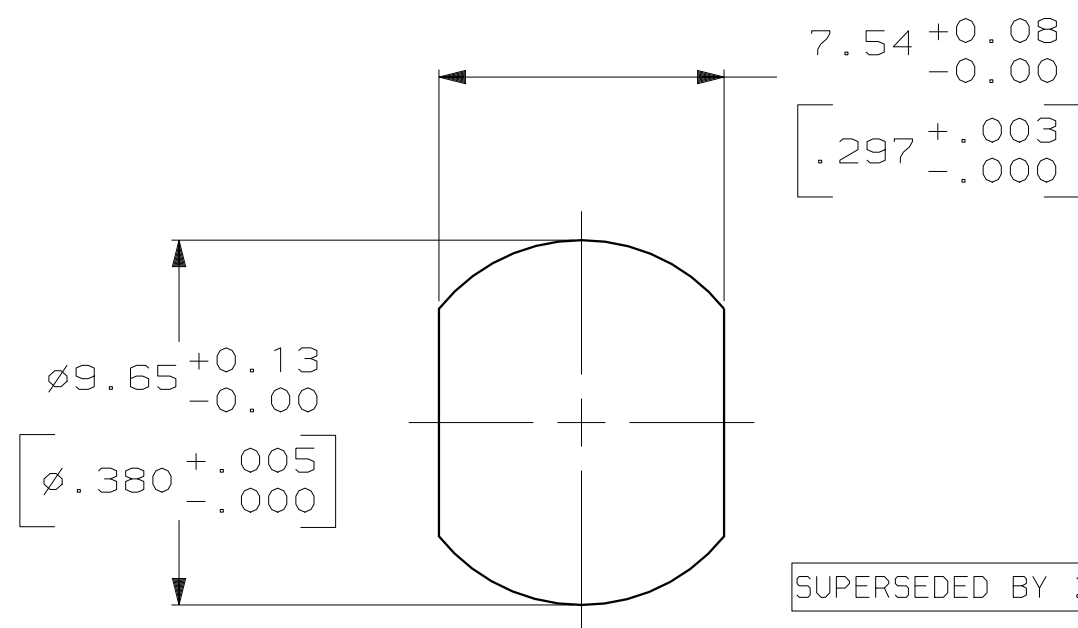

△ RECOMMENDED PANEL CUTOUT

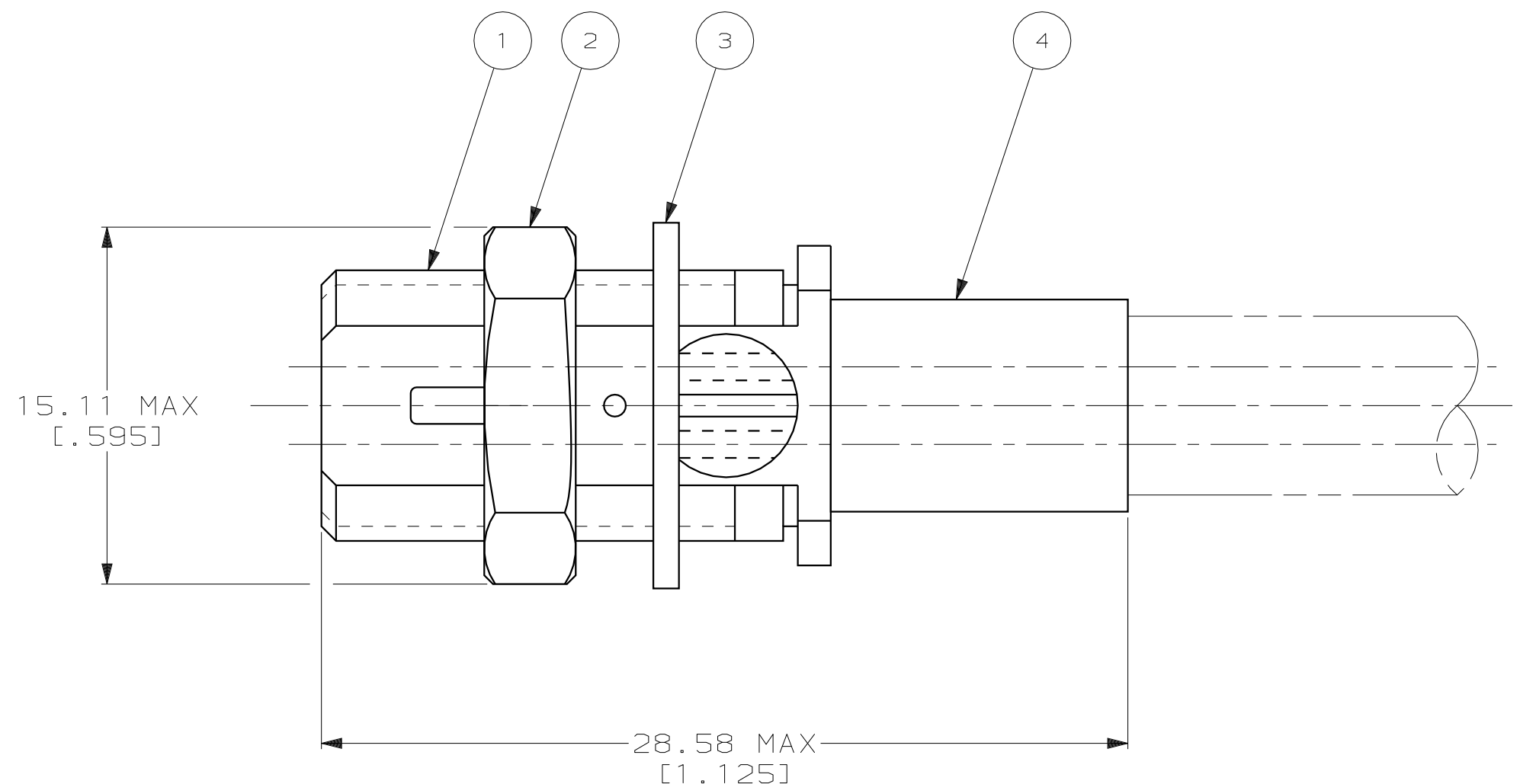

SUPERSEDED BY 2-329941-3	BELDEN 8451, 8641 & 8761	329056	1-329492-1	1-330249-1	2-330245-4	225689-4
	RG-108/U, 108A/U AND BELDEN 8759	1-329960-1	1-329492-1	1-330249-1	2-330245-3	225689-2
SUPERSEDED BY 2-329941-1	BELDEN 8737	1-329960-1	1-329492-1	1-330249-1	2-330245-4	225689-1
CABLE SIZE	④ FERRULE QTY=1	③ LOCKWASHER QTY=1	② NUT QTY=1	① RECEPTACLE ASSEMBLY QTY=1	PART NUMBER	

DO NOT SCALE PRINT. UNLESS SPECIFIED DIMENSIONS IN mm [INCHES] TOLERANCES ON :		DR 06-25-91 B.SCOTT		AMP AMP Incorporated Harrisburg, PA 17105-3608	
2 PLC DEC ± 0.41 [.016]	3 PLC DEC ± -	CHK 02/05/93 G.MICHAEL	APPD 02/05/93 G.MICHAEL	NAME	
ANGLES ± -	MATERIAL -	APPD 02/05/93 J.DAVIS	PRODUCT SPEC -	RECEPTACLE, THREADED, TWIN SERIES	
FINISH -	APPLICATION SPEC -	WEIGHT -	SCALE 5:1	SIZE C	CAGE CODE 00779
				DRAWING NO	225689
				SHEET	1 OF 1