

Digi-Key

Issue No. : C97-113

Date of Issue : Mar. 4, 1997

Classification : New Changed Revised

PRODUCT SPECIFICATION FOR INFORMATION

Product Description : Ceramic disc capacitor

Customers Part Number :

Product Part Number : ECKATS00000 (TYPE TS)

Applications : CONSUMER TYPE ELECTRIC EQUIPMENT

For other applications contact our person singed below.

Term of Validity : Mar. 3. 2002 from the date of issue

CUSTOMER USE ONLY	
This was certainly received by us. 1(one)copy is being returned to you.	Receipt Record # :
	Date of Recpt :
	Received by :
	Title :
	Dept :

Matsushita Electronic Components Co., Ltd.
Ceramics Division
〒571 1006 Kadoma, Osaka, Japan
Tel : Osaka(06) 908-1101(Rep.)
Fax : Osaka(06) 908-7735

Prepared by Ceramic capacitor section	
Contact Person :	<u>J. Fohgo</u>
Title :	Engineer
Authorized by :	<u>N. Suda</u>
Title :	Manager

- This product has not been manufactured with any ozone depleting chemical controlled under the Montreal Protocol.
- All the materials used in this part contain no brominated materials of PBBOs or PBBs as the flame-retardant.
- All the materials used in this part are registered material under the Law Concerning the Examination and Regulation of Manufacture, etc. of Chemical Substances.

1. Scope

This specification applies to the Notabilia of Ceramic Disc Capacitors Type TS.

Caution for Safety

Ceramic Capacitors may fail in a short-circuit mode (or an open-circuit mode) when subjected to severe conditions of electrical and/or environmental stresses beyond their specified ratings in the specification, resulting in burnout or glowing in the worst case.

Following precautions for circuit design and handling shall be taken into your major consideration.

2. Important practices which shall be observed for safety

2.1 Circuit Design

2.1.1 Check of operating conditions and rated performance

- Check the operating conditions and environmental conditions and then use the product within the rated performance which is defined in the specifications of the capacitor.

If the operating conditions do not conform to specified items, consult our company by showing the conditions. If the capacitors are used under operating conditions out of the specifications, deterioration of performance may occur, resulting in short circuit, open circuit, glowing and flaming in the worst case.

- If trouble of the capacitors may affect human life such as in aeronautical equipment, space equipment, and medical equipment, contact our business section before use.

2.1.2 Operating temperature

- Use the capacitors within the temperature range which is specified in the specifications.

2.1.3 Operating voltage

- Do not apply a voltage exceeding the rated voltage to the capacitors.

When the rated voltage of the capacitor is shown by the nominal AC line voltage, a voltage higher than the rated voltage by the fluctuation of the AC line voltage may be permitted.

CERAMICS DIVISION
MATSUSHITA ELECTRONIC COMPONENTS CO., LTD.
KADOMA, OSAKA, JAPAN

APPROVAL



CHECK

DESIGN

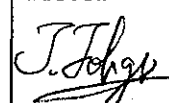

2.1.4 Restriction on operating location

- Do not use or/and store the capacitors under following environmental conditions;

(1) A location in the following environmental (weather) conditions

- a. To be exposed directly to water or salt water,
- b. Under conditions of dew formation,
- c. Under conditions of corrosive atmosphere such as hydrogen sulfide, sulfurous acid, chlorine and ammonia.

(2) A location where the conditions of vibration or shock exceed the specified range of the specifications.

2.2 Mounting and Processing

2.2.1 Plastic molding

- If another plastic molding is applied to the capacitors by your option, investigate a influence on reliability of the capacitors in your equipment. Some plastic molding may damage the capacitors with the stress by thermal expansion or shrinkage, or deteriorate the performance of capacitors with cracked gas or reaction gas from resin, or deteriorate the humidity resistance of capacitors.

2.3 Test

2.3.1 AC dielectric withstanding test

- Perform AC dielectric withstanding test for the noise suppression capacitors in AC primary circuit, under the specified conditions(voltage, time, and wave form).

Some test equipment may deform the wave form of applied voltage and apply a voltage of peak value more than $\sqrt{2}$ times of rms value, resulting in dielectric breakdown of the capacitors.

- The AC test voltage shall be applied gradually from 0 volt to the specified test voltage after the capacitor terminals are connected securely to the test equipment. When the specified voltage is applied directly for some reasons, apply it in the zero cross start method.

If the voltage is applied directly from equipment which does not use the zero cross start method, an abnormal voltage higher than the specified voltage may be generated, resulting in dielectric breakdown of the capacitors.

3. General practices which should be observed for safety

3.1 Mounting and Processing

3.1.1 Design of printed circuit board

- Prepare proper intervals of the holes for the capacitors in the printed circuit board.

3.1.2 Adjustment of mounting equipment

- When mounting capacitors by using automated assembly equipment, adjust the positioning of the equipment and replace the cutter periodically so that excessive force or shock is not applied to the capacitors in the process of chucking of the capacitors, pushing-up of the body, and lead clinching.
For adjustment of positioning of mounting equipment, see the dimensional tolerance of the capacitors in the specifications.

3.1.3 Soldering

(1) Soldering fluxes

The content of halogen in the flux should be 0.1 wt% or less.
(0.1 wt% is the percentage converted to chlorine.)

(2) Soldering

Perform soldering under the conditions specified in the specifications.
Do not dip the body of the capacitors in the solder when soldering.

(3) Cleaning

When using water-soluble soldering fluxes, clean sufficiently.
If the capacitors are cleaned with the printed circuit board,
check the influence on quality by cleaning under actual conditions.

3.2 Storage

- Do not store the capacitors under high temperature or high humidity. Store them indoors under a temperature less than 40°C and humidity of less than 75%.
Use them within one year. If the capacitors are stored long time (longer than one year), check the soldering performance before use.
- Avoid being exposed to direct sunlight and dew formation.

4. Notabilia for Safety Regulations

4.1 Application of type designation of safety capacitors

- When applying the safety capacitors in your equipment to a certification body, apply the type name and the nominal capacitance in pF instead of the part number.
In case of ECKATS222ME for example, "Type TS, 2200pF" should be applied.
(Note: The part number such as ECKATS222ME is not registered to certification bodies.)

4.2 Condition of enclosure of equipment for UL-Standard

- As nonconductive parts, such as cracked parts of outer coating, of a capacitor may be expelled during the discharge test(2) specified in common specification, applicable condition of capacitor in equipment is restricted in recognition by UL.
The intended end-use of the capacitor shall be in an appliance employing an enclosure having openings shown in the following condition (1) or (2).

- (1) The projected area of any opening in the top, back, sides, or front of the enclosure of the overall appliance, onto a plane perpendicular to a line passing through the center of the opening and the central axis of the capacitor does not exceed 0.20 square inch (1.3 cm²), or

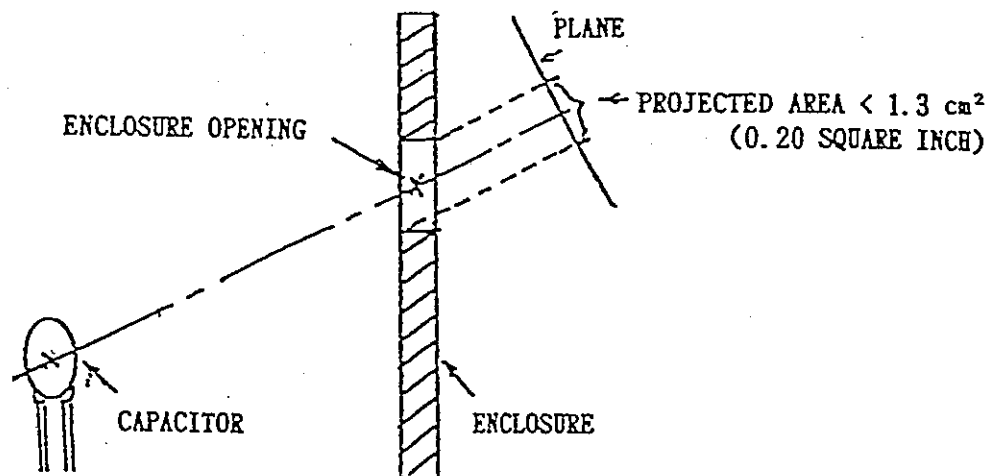

- (2) The minor dimension of the projected area is not more than 3/8 inch (9.5mm).

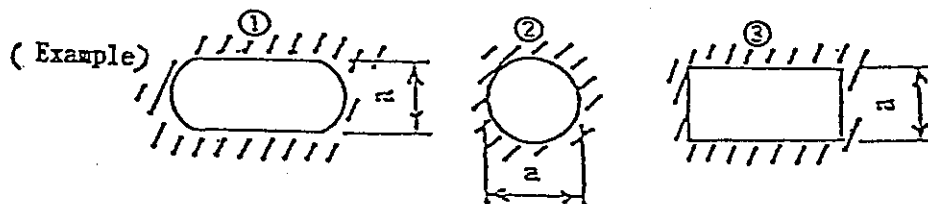

$$a < 9.5 \text{ mm (3/8 INCH)}$$

5. Notice

- If trouble occurs because of use of the capacitors under conditions exceeding those specified in the specifications, we cannot assume the responsibility for the trouble.

REVISION / REMARKS

1. Scope

This specification applies to Type TS Ceramic Disc Capacitors (Kinked Long Lead Type) which are recognized by certification body.

No-specified issues in this specification are shown in the common specification (151S-SCK-GSP-TS01E).

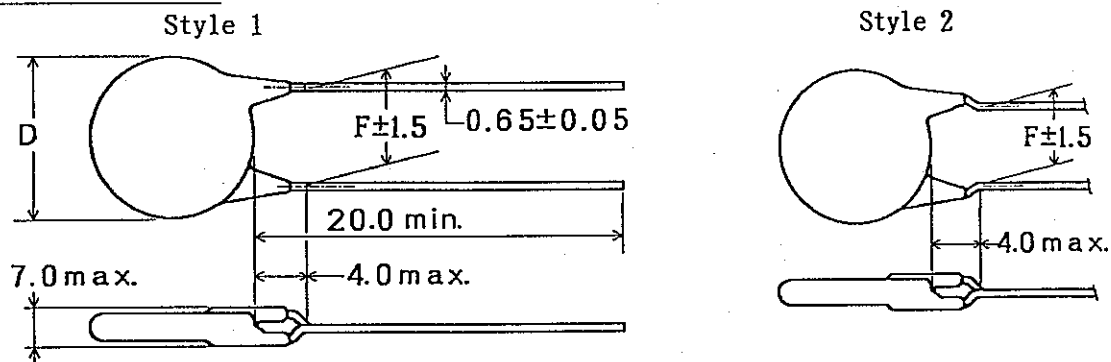
2. Style and Dimensions

Other dimensions same as Style 1.

3. Standard Products

unit : (mm)

Customer Part. No.	Matsushita Part No.	Nominal Cap. (pF)	Cap. Tol. (%)	Temp. Char.	Style	Dimension(mm)	
						D	F
	ECKATS101□B	100	±10 or ±20	B	1	7.0±1.0	7.5
	ECKATS221□B	220	±10 or ±20	B	1	7.0±1.0	7.5
	ECKATS471□B	470	±10 or ±20	B	1	7.0±1.0	7.5
	ECKATS102ME	1000	±20	E	1	7.0±1.0	7.5
	ECKATS152ME	1500	±20	E	1	8.0±1.0	7.5
	ECKATS222ME	2200	±20	E	1	9.0±1.0	7.5
	ECKATS332ME	3300	±20	E	2	11.5±1.0	7.5
	ECKATS472ME	4700	±20	E	1	14.0±1.0	10.0
	ECKATS472MF	4700	±20	F	2	11.5±1.0	7.5
	ECKATS103MF	10000	±20	F	1	16.0±1.5	10.0
	ECKATS472ME6	4700	±20	E	2	14.0±1.0	7.5
	ECKATS103MF6	10000	±20	F	2	16.0±1.5	7.5

Note 1: □ --- Capacitance Tolerance Code K(±10%) or M(±20%)

2: Suffix Code "6" are indicated for change in lead space(Dim."F") 10.0 ⇔ 7.5mm

Revisions/Remarks

CERAMICS DIVISION
MATSUSHITA ELECTRONIC COMPONENTS CO.,LTD
KADOMA, OSAKA, JAPAN

Approval

[Signature]

Check

Design

[Signature]

1. Scope

This specification applies to Ceramic Disc Capacitors Type TS which are recognized by safety certification body.

In case of discrepancy conflict between individual specification and this specification, the individual specification shall govern.

2. Related Standards

- IEC Pub. 384-14 2nd. Ed. (EN132400) : Fixed capacitors for electromagnetic interference suppression and connection to the supply mains(Sub-class Y2 and X1)
- BS EN 60065:1994 (BS 415:1994) : Sub-clauses 9.3.5, 13.1 and 14.2
- UL1414 : Across-the-Line, Antenna-Coupling and Line-by-pass Capacitors for Radio and Television type appliances.
- CSA C22.2 No. 1 : 6.12 Antenna and Line Isolation Capacitors
10 Across-the-Line Capacitors

3. Explanation of Part Numbers

(Example)

E C K A T S 3 3 2 M E
(1) (2) (3) (4) (5) (6) (7)

(1) Common code -----

Code	Class of Capacitors
E C K	Class 2 (Hi-K)

(2) Lead Style or Taping -----

Code	Style
A	Kinked long lead type
E	Kinked short lead type
N	Kinked lead taping type
Others	See the individual specification

(3) Type of Capacitors -----

Code	Type
T S	Type TS

(4) Rated Capacitance -----

The first tow digits are significant figures of capacitance and third one denotes number of following zeros.

Code(Ex.)	Rated Capacitance
1 0 1	100pF
2 2 2	2200pF
4 7 2	4700pF

Revisions/Remarks

CERAMICS DIVISION
MATSUSHITA ELECTRONIC COMPONENTS CO.,LTD
KADOMA. OSAKA. JAPAN

Approval

Check

Design



CERAMIC DISC CAPACITOR SPECIFICATION

No. 151S-SCK-GSP-TS01E

SUBJECT

Common specification for Cermic Disc Capacitors Type TS

Page 10 - 2

Date Jan.10.1997

(5) Capacitance Tolerance -----

Code	Capacitance Tolerance
K	±10%
M	±20%

(6) Temperature Characteristics -----

Code	Temp.Characteristics
B	Char. B
E	Char. E
F	Char. F

(7) Suffix ----- See the individual specification.

4. Certification Standards and Certificate Numbers

Certificat -ion Body	Standard No.	Certificate Numbers	Details of Certification			Operating Temp. Range
			Sub-Class	Rated Volt.	Test Volt.	
BSI	BS EN 60065:1994 BS EN132400:1995	8035	Y2	250VAC	1500VAC	-25~ +125°C
			X1	250VAC	1075VDC	
VDE	EN 132 400 :1994	94647	Y2	250VAC	1500VAC	-25~ +125°C
			X1	250VAC	1075VDC	
		94646	Y2	250VAC	1500VAC	-25~ +125°C
			X1	250VAC	1075VDC	
		94648	Y2	250VAC	1500VAC	-25~ +125°C
			X1	250VAC	1075VDC	
SEV	EN 132 400 :1994	96.1 10369.06	Y2	250VAC	1500VAC	-25~ +125°C
			X1	250VAC	1075VDC	
SEMKO	EN 132 400 :1994	9618031 01	Y2	250VAC	1500VAC	-25~ +125°C
			X1	250VAC	1075VDC	
FIMKO	EN 132 400 :1994	192031-01	Y2	250VAC	1500VAC	-25~ +125°C
			X1	250VAC	1075VDC	
NEMKO	EN 132 400 :1994	P96102354	Y2	250VAC	1500VAC	-25~ +125°C
			X1	250VAC	1075VDC	
DEMKO	EN 132 400 :1994	305880	Y2	250VAC	1500VAC	-25~ +125°C
			X1	250VAC	1075VDC	
UL	UL1414	E62674		250VAC	1500VAC	-25 ~ +85°C
CSA	CSA C22.2 No.1	LR58064-12		250VAC	1500VAC	-25 ~ +85°C
Electrical Appliance and Material Control Low in Japan			Applicable			

Revisions/Remarks

5. Markings









(1) Matsushita's Trade Mark : 

(2) Type Designation : TS

(3) Sub-Class according to EN132400 : Y2 X1

(4) Rated Voltage and nature of supply : 250~

(5) Rated Capacitance : 3 digit code

(6) Approved mark VDE:  , SEV:  , SEMKO:  , FIMKO:  ,
 NEMKO:  , DEMKO:  , UL:  , CSA: 

(7) BSI Standard mark : BS415

(8) Plant Code : H

(9) Date code : $\begin{matrix} \circ & \circ \\ \swarrow & \searrow \\ \text{Manufacture month} \\ \text{(Jan.:1, Feb.:2, Mar.:3, Apr.:4, May :5, June:6,} \\ \text{July:7, Aug.:8, Sep.:9, Oct.:0, Nov.:N, Dec.:D)} \\ \swarrow & \searrow \\ \text{Manufacture year (1997:7, 1998:8, 1999:9, 2000:0 \dots)} \end{matrix}$

Marking Example

(Front Side)

(Back Side)

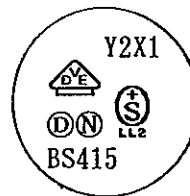
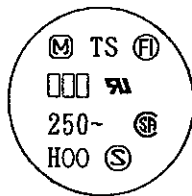

(note)

$\square\square\square$ ---capacitance
 00 ----date code

Revisions/Remarks

CLASSIFICATION		No. 151S-SCK-GSP-TS01E
CERAMIC DISC CAPACITOR SPECIFICATION		Page 10 - 4
SUBJECT		Date Jan.10.1997
Common specification for Cermic Disc Capacitors Type TS		

6. Operating Temperature Range
 -25 to +125 °C (-25 to +85 °C for UL and CSA)

7. Performance
 The performance and test method shall be Table 1.

8. Test Conditions
 The test and measurement shall be made under the standard test conditions (temperature of 15 to 35°C, relative humidity of 45 to 75 %, and atmospheric pressure of 86 to 106 kPa) unless other specified.
 However, when uncertainty occurs in the judgment or especially required, test and measurement shall be made under the judgment conditions (temperature of 20±2 °C, relative humidity of 60 to 70%, and atmospheric pressure of 86 to 106 kPa).

9. Structure, Shape and Dimensions
 The capacitor is of such construction that the capacitor element composed of a disc type ceramic dielectric and electrodes are securely connected with the lead terminals, electrically and mechanically, and that the capacitor element is protected by a resin which has external insulation, humidity resistance and durability to the highest operating temperature.
 The lead terminals are appropriately treated for easy soldering.
 The details of structure and materials are shown in sub-clause 10.
 Shape and Dimensions are shown in individual specifications.

Table 1

No.	Item	Requirement	Test Method
1	Appearance and Dimensions	Without damage of visual examination and within dimension in individual specification.	Dimensions shall be checked by using such measuring instruments as slide caliper or micrometer.
2	Markings	Shall be easily legible.	Shall be examined by visual checked or observe under a magnifying glass.
3	Voltage Proof Between Terminals	No breakdown or flashover.	The AC test voltage (50Hz or 60Hz) shall be raised from 0 V to the 2600VAC at a rate not exceeding 150V/sec. and shall be kept for 1 minute.

Revisions/Remarks

Table 1 (Continuation)

No.	Item		Requirement	Test Method	
3	Voltage Proof (Continuation)	Between Terminals and Enclosure	No breakdown or flashover.	The AC test voltage shall be applied between the leads and the metal foil which is wound on the body of the capacitor. The distance between the bottom of leads and metal foil shall be 2.6mm. The test voltage shall be raised according to above condition of "Between Terminals".	
4	Insulation Resistance	Between Terminals	10000M Ω min.	Measurement Voltage : 500VDC Test Time : 60 \pm 5sec.	
		Between Terminals and Enclosure	6000M Ω min.		
5	Capacitance		Within specified tolerance.	Measuring Frequency : 1kHz \pm 20% Measuring Voltage : 1.0 \pm 0.2Vrms Measuring Temperature : 20°C	
6	Dissipation Factor(tan δ)		0.025 max.		
7	Temperature Characteristics		T. C.	Measuring Temperature Range : -25 to 85°C Reference Temperature : 20°C	
			B		\pm 10%max.
			E		+20, -55% max.
			F		+30, -80% max.
8	Lead Strength	Lead Pull Test	Without damage.	A static load of 10N shall be applied to the terminal in the axial direction for 10 \pm 1 sec.	
		Lead Bend Test	Without damage.	A static load of 5N shall be applied to the terminal in the axial direction. The capacitor shall be inclined through an angle 90', and be returned to its initial position, and then be repeated once more to the opposite direction.	
9	Vibration Test	Appearance	Without distinct damage	Vibration Frequency : 10-55-10Hz for 1 minute. Amplitude : 1.5 mm Operating Time : Shall be applied for a period 2 hours in each of 3 mutually perpendicular directions.	
		Capacitance	Within specified tolerance.		
		Dissipation Factor	0.025 max.		

Revisions/Remarks

Table 1 (Continuation)

No	Item		Requirement	Test Method	
10	Solderability		A new uniform coating of solder shall cover a minimum $\frac{3}{4}$ of the surface of leads.	Flax : Rosin and Ethyl alcohol composition (25wt%) Temperature of solder : $235 \pm 5^\circ\text{C}$ Time of immersion : 2 ± 0.5 sec. Speed of immersion : 25 ± 5 mm/sec. Location of immersion : Upto 4 mm from root of lead.	
11	Solder Heat(1)	Appearance	Without distinct damage.	Flax : Rosin and Ethyl alcohol composition(25wt%) Temperature of solder : $260 \pm 5^\circ\text{C}$ Time of immersion : 10 ± 1 sec. Location of immersion : After inserted into heat shant boad, upto 1.5 to 2.0 mm from root of lead.	
		Capacitance Change	$\pm 10\%$ max.		
12	Solder Heat(2)	Appearance	Without distinct damage.	Flax : Rosin and Ethyl alcohol composition(25wt%) Temperature of solder : $350 \pm 10^\circ\text{C}$ Time of immersion : 3.5 ± 0.5 sec. Location of immersion : Upto 4 mm from root of lead. After testing, the capacitors shall be subjected to the room temperature for a period 24 hours, and then shall be measured.	
		Capacitance Change	T. C.		Cap. Cange
			B		$\pm 5\%$ max.
			E		$\pm 15\%$ max.
F	$\pm 20\%$ max.				
	Voltage Proof	Shall meet to No. 3			
13	Solvent Resistance		The marking shall be legible.	Kind of solvent : Isopropyl alcohol Time of immersion : 5.0 ± 0.5 min. After removal from the solvent, the marking area shall be rubbed with cotton wool. Ten strokes shall be applied over the marking area with a force $5 \pm 0.5\text{N}/\text{cm}^2$ and a rate of about two stroks per second.	
14	Damp Heat	Appearance	Without distinct damage	Temperature : $40 \pm 2^\circ\text{C}$ Humidity : 90 to 95% RH Test Hours : 500 +24/0 hours After testing, the capacitors shall be subjected to the room temperature (15 to 35°C) for a period of 1 to 2 hours and shall be measured.	
		Capacitance Change	$\pm 15\%$ max.		
		Insulation Resistance	3000 M Ω min.		
		Voltage Proof	Shall meet to No. 3		

Revisions/Remarks

Table 1 (Continuation)

No.	Item	Requirement	Test Method
15	Damp Heat Load	Appearance Without distinct damage	Temperature : 40 ± 2 °C Humidity : 90 to 95% RH Test Hours : 500 +24/0 hours Test Voltage : Rated Voltage (250VAC) After testing, the capacitor shall be subjected to the room temperature (15 to 35°C) for a period of 1 to 2 hours and shall be measured.
	Capacitance Change	$\pm 15\%$ max.	
	Insulation Resistance	3000M Ω min.	
	Voltage Proof	Shall meet to No.3	
16	Impulse Voltage Test	Shall be no permanent breakdown or flashover. Regular impulse wave form shall be shown by the monitor for the during impulse test.	Shall be subjected to 3 impulses as shown below. This test is to be carried out as a sequence with the Endurance Test(1).

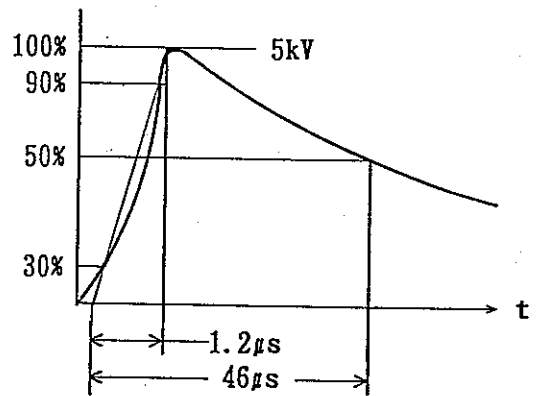

Impulse Voltage Test Circuit

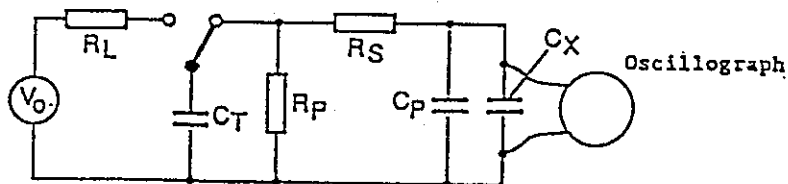

Cx : Capacitor under test	100 to 3900pF	4700 to 12000pF
CT : Charging capacitor	0.25 μ F	0.25 μ F
Cp : Parallel capacitor	7800pF	7800pF
Rs : Series resistor	62 Ω	45 Ω
RP : Parallel resistor	234 Ω	234 Ω
RL : Loading resistor		
Uo : DC voltage source		

Revisions/Remarks

Table 1 (Continuation)

No.	Item	Requirement	Test Method	
17	Endurance Test	Apperance	Without distinct damage. This test shall be started after Impulse Voltage Test of No.16. Temperature : 125 ±3 °C Humidity : 50%RH max. Test Hours : 1000 hours Test Voltage : 425VAC With the voltage raise to 1000VAC for a period of 1/10 seconds once an hour.	
	(Related by IEC384 -14 sub-clause 4.14)	Capacitance Change		±20% max.
		Insulation Resistance		3000MΩ min.
		Voltage Proof		Shall meet to No.3
18	Discharge Test (1)	Apperance	Without distinct damage. The test capacitor (Ct) shall be subjected to 50 discharges at a maximum rate of 12 times/minute, from a 1000pF capacitor chaged to 10kVDC. as shown in the circuit below.	
		Voltage Proof Voltage		Shall meet to No.3
19	Discharge Test (2)	No glow or flame on the cheese-cloth wound on capacitor body.	The test capacitors (Cx) shall be subjected to four discharges from a dump capacitor (Cd) charged to a voltage value(Vdc), within an interval of 5 seconds between successive discharges. The test capacitor shall be subjected to Vac during the test and for 30 seconds after the test.	

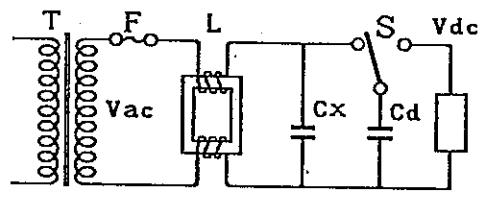
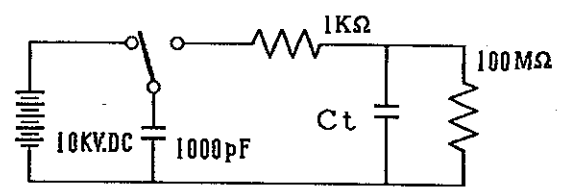

Vac= 240VAC

$$Vdc = 5 \times \frac{Cd+Cx}{Cd} \text{ (kV)}$$

Cx(tested Capacitors)	Cd
100pF to 0.005μF	0.005μF
0.0051μF to 0.05μF	0.05μF

Revisions/Remarks

Table 1 (Continuation)

No	Item	Requirement	Test Method
20	Enclosure Test	Capacitors shall not continue to flame for 15 seconds after the first and second applications, and not more than 60 seconds after the third application.	Capacitor shall be subjected to three 15 seconds application of a test flame. The test flame is to be a 19 mm high flame from a 9.5 mm diameter tirril burner with the airports of the burner closed.
21	Passive Flammability Test	Capacitors shall not continue to flame for 30 seconds after the application.	Capacitor shall be subjected to 20 seconds application of a test flame. The test flame is to be a 12 mm high flame from a 0.5±0.1 mm inner diameter and 0.5 mm max. outer diameter burner.
22	Active Flammability Test	The cheese cloth around the capacitor shall not burn with a flame.	The test capacitors (Cx) shall be subjected to 20 discharges from a tank capacitor (Ct), charged to a voltage that, when discharged, places Ui across the capacitor under test (Cx). The interval between successive discharges shall be 5 seconds. The test capacitor shall be individually wrapped of cheese cloth.

Typical circuit for pulse loading

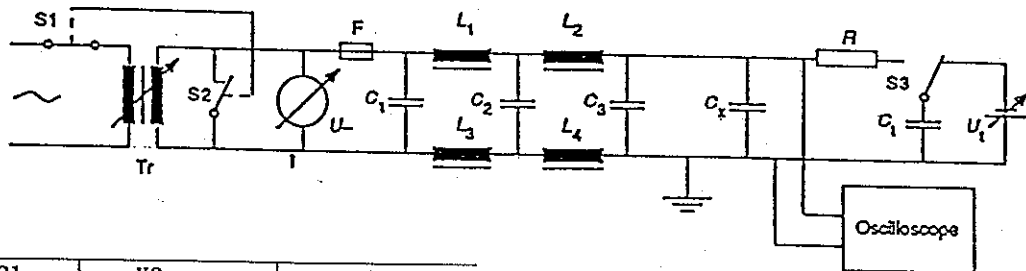

Sub-Class	Y2	X1
U~	AC250V±5%	
Ui	5kV +7, -0 %	4kV +7, -0 %
C1, C2	filter capacitor 1μF±10%	
C3	capacitor 0.033μF±5%/10kV	
Cx	capacitor under test	
Ct	tank capacitor 3μF±5%/10kV	
L1-L4	choke 1.5mH±20%/16A	
R	resistor 100 Ω±2%	

Hi-voltage pulse wave

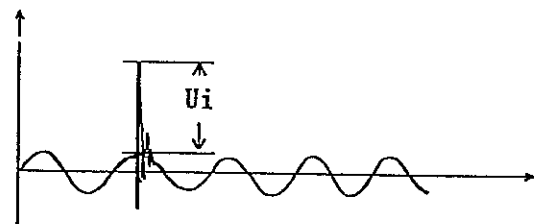

Revisions/Remarks

CLASSIFICATION

CERAMIC DISC CAPACITOR SPECIFICATION

No. 151S-SCK-GSP-TS01E

SUBJECT

Common specification for Cermic Disc Capacitors Type TS

PAGE 10 - 10

DATE Jan. 10. 1997

10 Construction and Materials

Construction

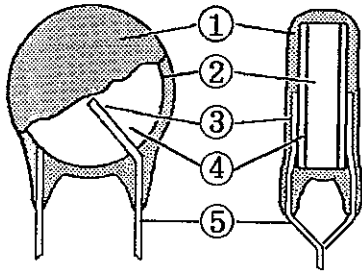

Materials

No.	Name	Materials
①	Insulation Coating	Epoxy compound resin Flammability class: UL 94, V-0
②	Dielectric Element	Ceramics
③	Solder	Sn-Pb Solder
④	Electrodes	Nickel
⑤	Leads Wire	Solderd copper wire

Revisions/Remarks