

PART NUMBER	REV	FIRST USED
567947-1	B	854040-3

TERMINAL NAME: TYPE III PIN & SOCKET						
SOCKET	PAD LTR	VISIBLE	CRIMPING DATA			
			CRIMP HEIGHT	WIRE SIZE		
788088			A	.025 ±.001 (0.64 ±0.03mm)	28	
			B	.024 ±.001 (0.61 ±0.03mm)	30-32 <sup>4</sup>	
			C	NOT	USED	
			D	NOT	USED	
			CRIMP	SIZE	TYPE	RANGE
			WIRE	.055 [1.40mm]	F	32-28
			INSUL	.055 [1.40mm]	0	-
WIRE STRIP LENGTH	TERM APPL SPEC	FEED	APPL INSTRUCTION	SET UP GAGE	LAYOUT	
.141-.171	114-10004	.500	SEE CUSTOMER MANUAL	NONE	-	

SIM TO HDM NONE

REF	QTY	REV	DESCRIPTION	ITEM NO
				70
				69
				68
				67
				66
				65
				64
				63
				62
				61
				60
				59
				58
				57
				56
				55
				54
				53
				52
				51
				50
				49
				48
				47
				46
				45
				44
				43
				42
				41
				40
				39
				38
				37
				36
				35
				34
				33
				32
				31
				30
				29
				28
				27
				26
				25
				24
				23
				22
				21
				20
				19
				18
				17
				16
				15
				14
				13
				12
				11
				10
				9
				8
				7
				6
				5
				4
				3
				2
				1

QTY	REV	DESCRIPTION	ITEM NO
2	-	C 7-354779-4 PIN, WIRE DISC (.3360)D	129
2	-	C 7-354779-2 PIN, WIRE DISC (.3350)C	128
			127
			126
1	-	A 986950-1 WASHER, FLAT PRECISION	125
1	-	A 217238-3 GENERAL INSTRUCTION PACKAGE	124
			123
			122
1	-	A 4-21028-0 PIN, SLT SPR (ø.093x.75) ST GDE PL	121
1	-	B 690701-2 PLATE, SERIAL NO.	120
2	-	A 21899-2 WASHER, FLAT (#10) S G ADJ BLK	119
			118
2	-	A 21024-5 WASHER, LOCK (#10) ADJ BLOCK	117
			116
			115
2	-	A 21024-2 WASHER, LOCK (#4) FRONT STP GUIDE	114
REF	-	A 21024-4 WASHER, LOCK (#8) FEED FINGER	113
2	-	A 21024-4 WASHER, LOCK (#8) DEP-HOLD	112
REF	-	A 21024-4 WASHER, LOCK (#8) STRIPPER	111
			110
			109
1	-	A 21018-5 NUT, HEX (#6) HOLD DOWN	108
			107
			106
			105
			104
1	-	A 21009-2 SCR, 5KT SET (1/4-20x.25 LW) RAM	103
			102
4	-	A 21017-2 SCR, DRIVE (#2x.19) ID PLATE	101
1	-	B 819347-1 PLATE, IDENTIFICATION	100
2	-	A 3-21002-0 SCR, BHC (10-32x.88) DRAG	99
1	-	A 22733-8 SCR, BHC (8-32x.38 LW) ANVIL	98
			97
1	-	A 3-21000-8 SCR, 5HC (10-32x.88) MOUNTING	96
1	-	A 2-21002-7 SCR, BHC (10-32x.50) 5G ADJ BLK	95
6	-	A 2-21002-2 SCR, BHC (8-32x.50) SHEAR-TERM SUP	94
			93
			92
1	-	A 1-21002-7 SCR, 5HC (6-32x.50) CAM	91
2	-	A 2-21000-7 SCR, 5HC (8-32x.50) SCR BLK	90
			89
			88
2	-	A 2-21000-7 SCR, 5HC (8-32x.48) DEP-HOLD DOWN	87
REF	-	A 2-22603-0 SCR, HEX HD (8-32x.31) FEED FINGER	86
2	-	A 1-21000-3 SCR, 5HC (4-40x.25) FT ST GUIDE	85
REF	-	A 22733-9 SCR, BHC (8-32x.50 SL) STRIPPER	84
			83
			82
1	-	A 3-22603-1 SCR, HEX (10-32x.38) 5G ADJ BL	81
			80
			79
			78
2	-	B 463310-9 BLADE, STRIPPING (#28)	77
			76
			75
1	-	A 690603-1 SPRING, ASSIST	74
1	-	A 23030-1 SCR, 5KT CAP (6-32x.25) CP DSC	73
			72
			71

QTY	REV	DESCRIPTION	ITEM NO
-1	U/M	DWG SIZE	
		PART NO	
		DESCRIPTION	

QTY	REV	DESCRIPTION	ITEM NO
-1	U/M	DWG SIZE	
		PART NO	
		DESCRIPTION	

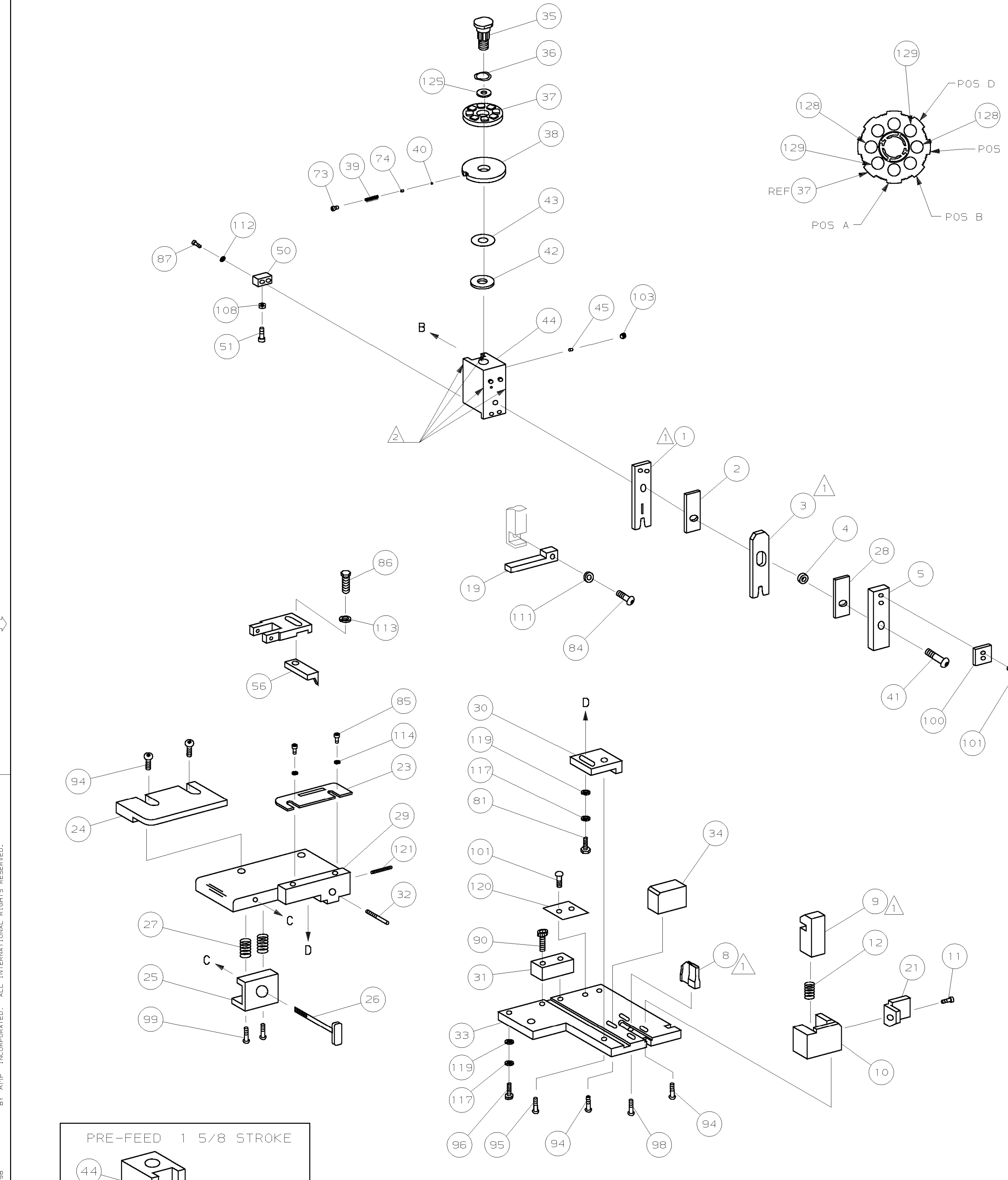

<sup>1</sup> RECOMMENDED SPARE PARTS.  
<sup>2</sup> GREASE LIGHTLY.  
<sup>3</sup> ITEM NOT SHOWN  
<sup>4</sup> 30 & 32 GA WIRE REQUIRE ENGINEERING APPROVAL.

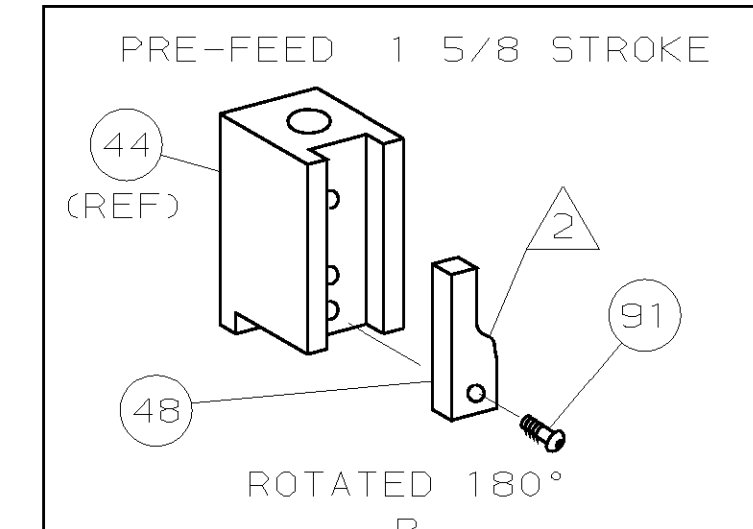

THIS DRAWING IS A CONTROLLED DOCUMENT

THIS DRAWING IS UNPUBLISHED. MAR 11, 1988  
 RELEASED FOR PUBLICATION BY AMP INCORPORATED. ALL INTERNATIONAL RIGHTS RESERVED.

LOC A  
 DIST 66

DIMENSIONS IN INCHES. DO NOT SCALE PRINT. TOLERANCES UNLESS OTHERWISE SPECIFIED:		MACHINING		FINISH	
1-6-98	APP T. ELBIN	HT TR		FIN	
DR D. SALTZER	REL	AMP Incorporated Harrisburg, PA 17105-3608			
CHK 1-7-98 C. ERISMAN		NAME STRIPPER CRIMPER APPLICATOR MACHINE REF STRIPPER CRIMPER			
SCALE	DWG NO 567947	SHEET 1 OF 1 REV B			

CAGE CODE 00779 CUSTOMER AND ASSEMBLY DRAWING RESTRICTED TO