

NUMBER
201607

NOTES:

⚠️ OBSOLETE PARTS: OBSOLETE CIS STREAMLINING PER D.RENAUD/D.SINISI

	201607-1	1. AS SHOWN
OBSOLETE	201607-2	1. SAME AS -1 EXCEPT; 2. FINISH OF ITEM 1, .0001 MIN SILVER OVER .00005 MIN NICKEL
OBSOLETE	201607-3	1. SAME AS -1 EXCEPT; 2. FINISH OF ITEM 1, .0001 MIN GOLD OVER .0001 MIN SILVER
OBSOLETE	201607-4	1. SAME AS -1 EXCEPT; 2. MTD ON TAPE.
	201607-5	1. SAME AS -1 EXCEPT; 2. FINISH-.000050 GOLD MIN OVER .000050 MIN NICKEL.
	201607-6	1. SAME AS -5 EXCEPT; 2. MTD ON TAPE.

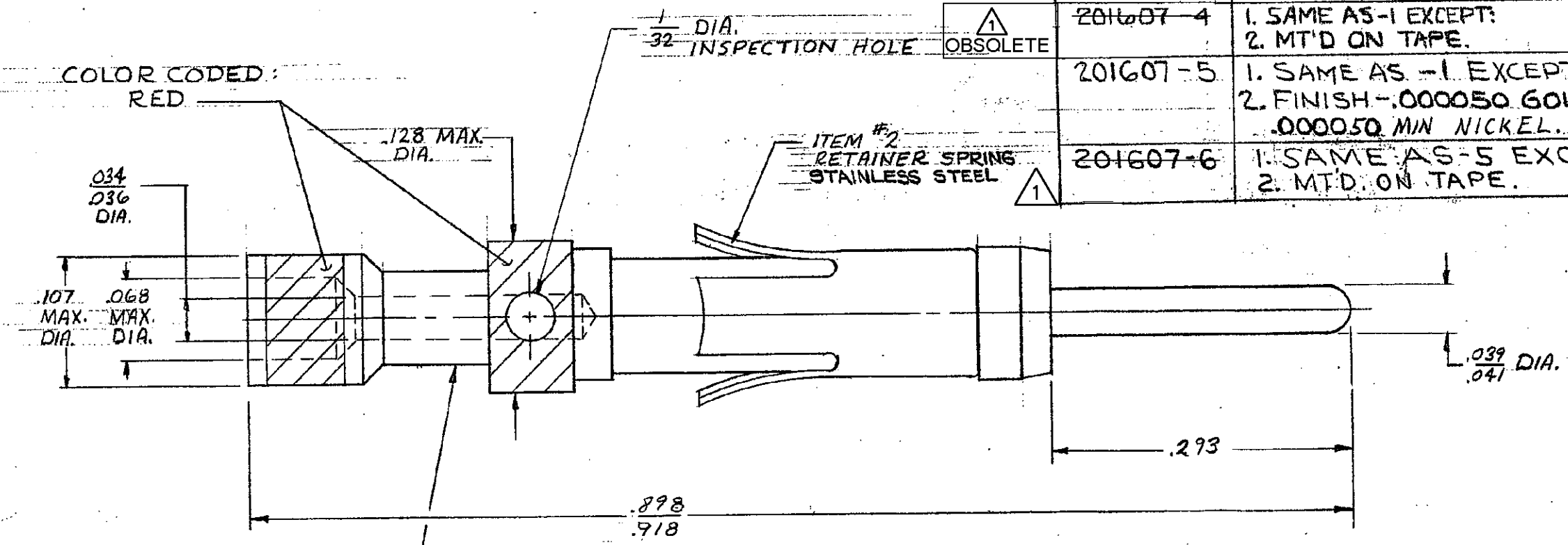

ITEM #1
PIN BODY
COPPER ALLOY
.00003 MIN GOLD OVER
.00005 MIN NICKEL

WHEN ORDERING CONTACT ON TAPE, ORDER BY THE TAPE NUMBER PLUS THE PACKAGING CODE AS FOLLOWS:
1. FOR USE WITH AMP TAPETRONIC, PNEUMATIC TOOL—
A. 1000 PARTS TO A BOX ADD PACKAGING CODE: 1MBOX
2. FOR USE WITH 4/8 INDENT STRIPPER CRIMPER—
A. 1000 PARTS TO A REEL ADD PACKAGING CODE: 1MREEL
B. 5000 PARTS TO A REEL ADD PACKAGING CODE: 5MREEL

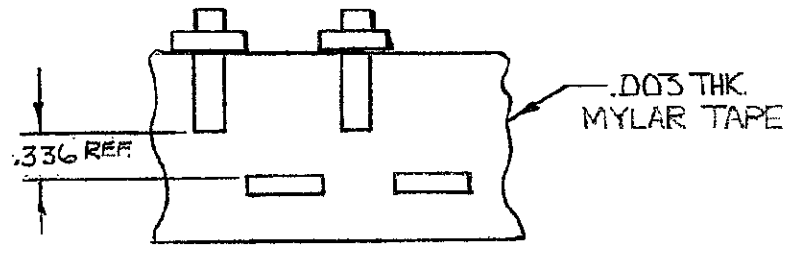

TAPE MTD ASS'Y
201607-4 AND
201607-6 ONLY.

DIMENSIONS IN INCHES. DO NOT SCALE PRINT.
PROPOSAL NO
47
PRINT DIST
3

M1	REVISED PER ECO-09-026346	KK	26NOV
		AEG	09
M	REACTIVATE -4 PER EC	65	6.9.98
	OGIC-62-98		
L	OBS-3,-4 PER ECN B05816	RWD	1/92
K	OBS-2 PER ECN B03038	J.R.	10/89
J	REV PER ECN B02619	THW	3.89
H	REACTIVATE-6/ECN	THW	8.88
G	REVISED	THW	9.87
F	OBSOLETE -6	J	7.24
E	ADDED-6 PER	B	2.02
D2	NOTE ADDED	B	1.41
D1	REVISED	B	1.19
D	REV. RETAINER SPRING TO SST	Z	3.02
C2	ADDED -4	J	3.61
C	REVISED	L	1.5
B	REVISED	K	1.22
A	REVISED	S	3.41
LTR	REVISION RECORD	ECA	BY DATE

TOLERANCES
EXCEPT AS NOTED
DECIMALS: ± .005
FRACTIONS: ± 1/64
ANGLES: ± 1/2°

MATERIAL	SEE CALL OUT	DR	J. Kaufman 12-1-61	ENGR	J.B.M. 12-5-61
HEAT TREAT	H	CHK	J. Williams 12-5-61	APP	J.C. Cusby 12/5/61
FINISH	SEE CALL OUT	 AMP INCORPORATED HARRISBURG, PENNA.			
NAME	#20 PIN CONTACT ASS'Y				
WIRE SIZE 28-24-.035-.055 INS. DIA					
SCALE	10:1	LOC	FT	NO	B 201607
REV					M1

CUSTOMER DRAWING