

THIS DRAWING IS UNPUBLISHED. RELEASED FOR PUBLICATION  
 © COPYRIGHT BY TYCO ELECTRONICS CORPORATION. ALL RIGHTS RESERVED.

LOC	DIST	REVISIONS			
P	LTR	DESCRIPTION	DATE	DWN	APVD
AF	50				
		N	REVISED PER ECR-06-010412	03NOV06	HMR KR

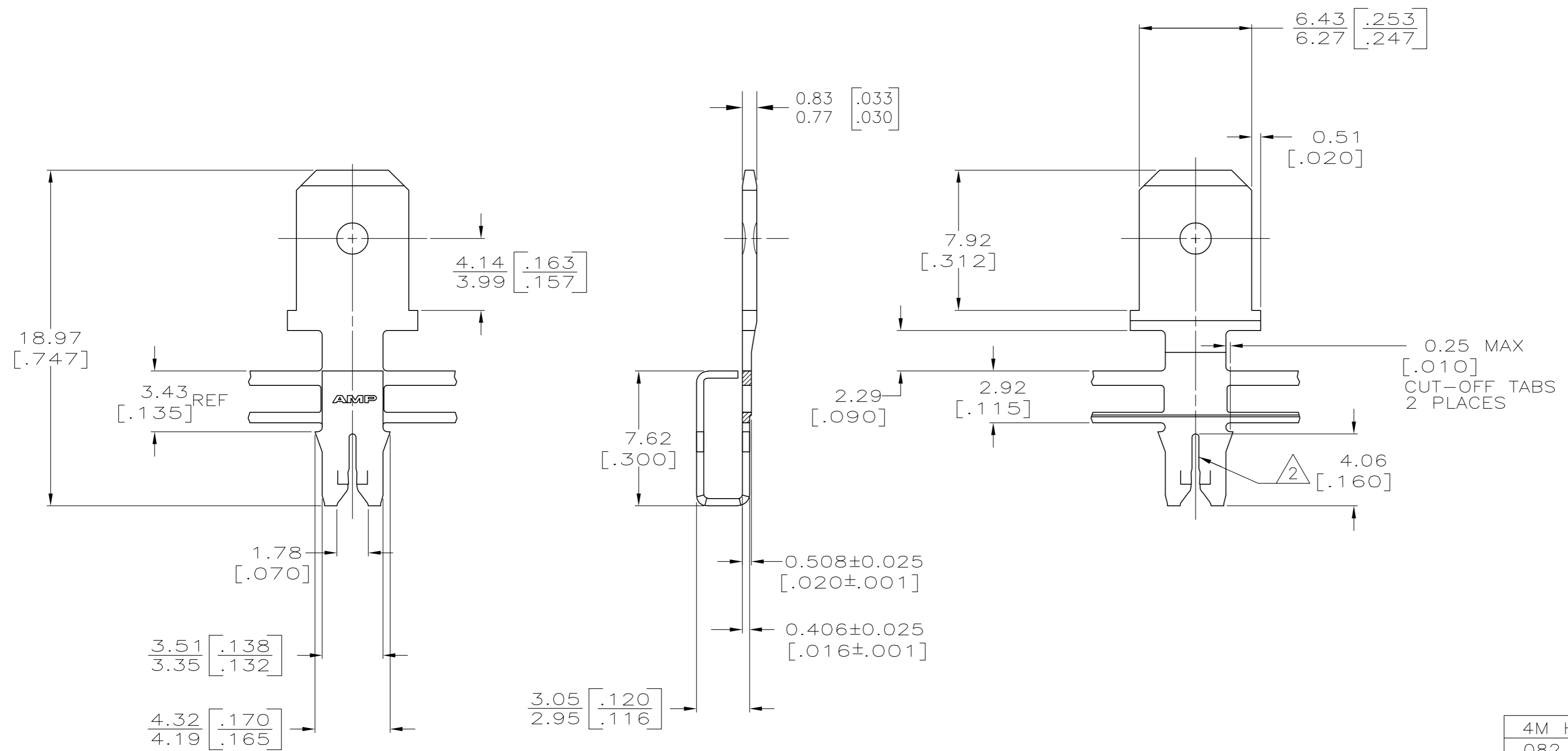

- 1 CONTINUOUS STRIP ON REELS WITH TERMINALS LOCATED ON 8.38 [.330] CENTERS.
- 2 SLOTTED TERMINAL A SINGLE MAGNET WIRE, COPPER RANGE IS 0.64-0.81mm [#22-#20] AWG.
- 3 AFTER INSERTION INTO PLASTIC HOLDER TAB PORTION MUST BE BENT OVER 45° TO 90° OR POTTED-IN TO PREVENT PULL-OUT WHEN MATING RECEPTACLE IS DISCONNECTED.



MATERIAL	PART NO
4M HARD PRE-MILLED BRASS	62653-3
082 HARD PRE-MILLED BRASS	62653-2
4M HARD PRE-MILLED BRASS	62653-1

THIS DRAWING IS A CONTROLLED DOCUMENT.		DWN MICHAEL S. FEHER 1/3/92	Tyco Electronics Corporation Harrisburg, PA 17105-3608	
DIMENSIONS: INCHES		CHK PHILLIP FORTNEY 1/6/92		
TOLERANCES UNLESS OTHERWISE SPECIFIED:		APVD NELSON E. NEFF 1/6/92	NAME TAB, 6.35 [.250] FASTON™ MAG-MATE™	
0 PLC ± - 1 PLC ± - 2 PLC ± 0.25 [.010] 3 PLC ± - 4 PLC ± - ANGLES ± -		PRODUCT SPEC 108-2012	SIZE A2	CAGE CODE 00779
MATERIAL SEE TABLE		FINISH 0.002037 [.000080]	DRAWING NO 114-2046	DRAWING NO C=62653
		WEIGHT -	RESTRICTED TO -	SCALE 5:1
		CUSTOMER DRAWING	SHEET 1 of 1	REV N