

Aug.1.2018 Copyright 2018 HIROSE ELECTRIC CO., LTD. All Rights Reserved.
 In case that the application demands a high level of reliability, such as automotive,
 please contact a company representative for further information.

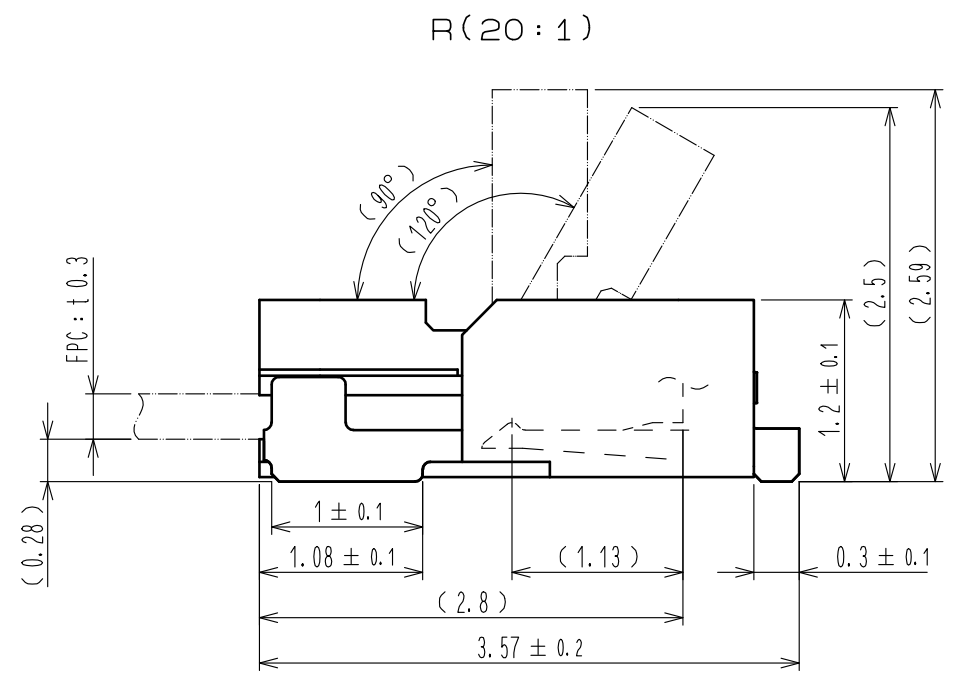
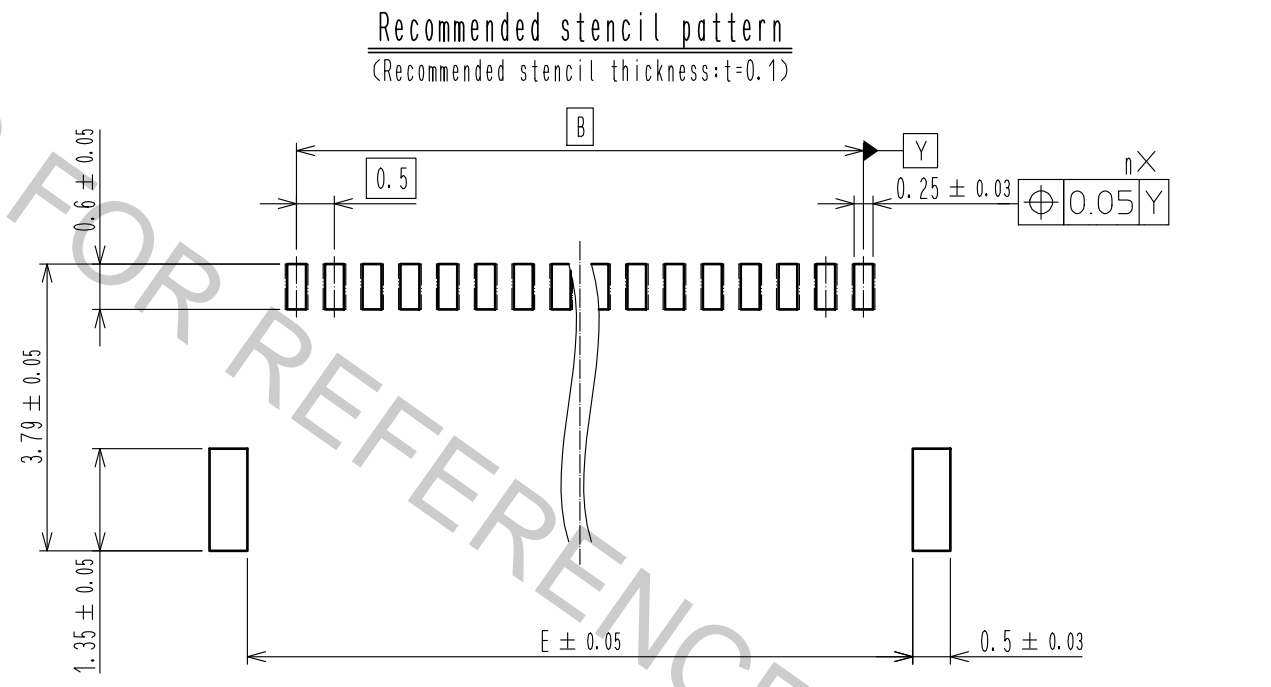
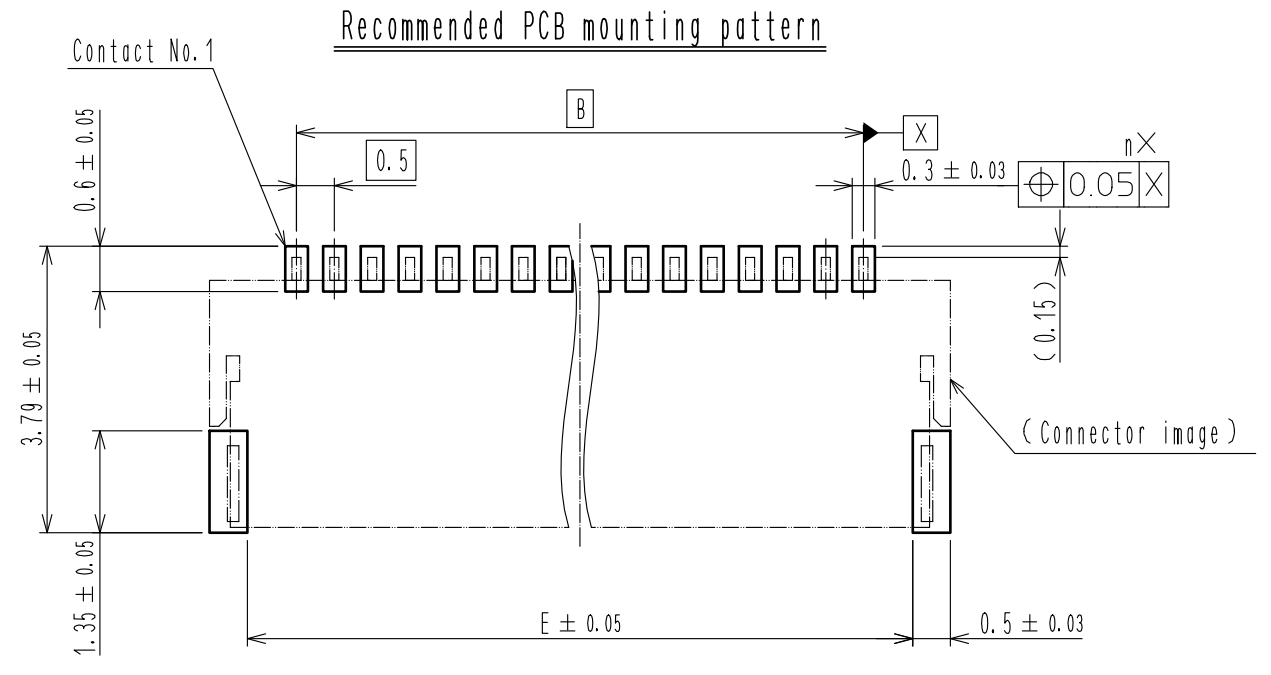
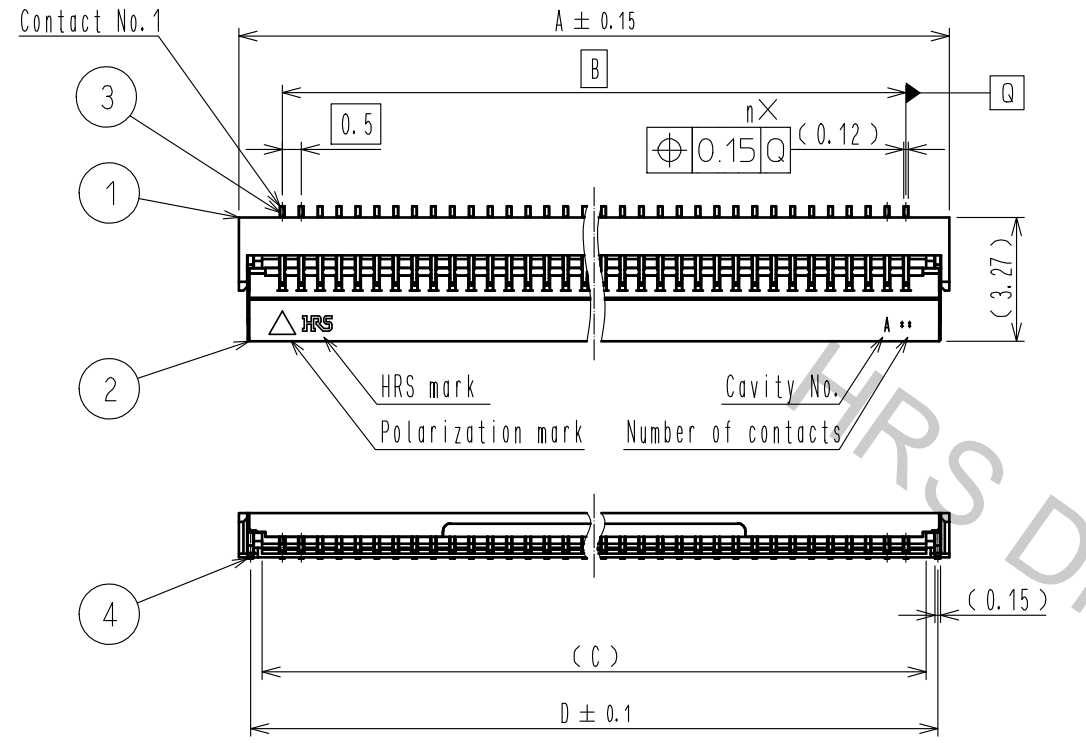

- Notes
- The dimension in parentheses are for reference.
 - Lead co-planarity including reinforced metal fittings shall be 0.1MAX.
 - To be delivered with tape and reel packaging.
 - Note that preventive hole for sink mark could be added for improvement.
 - The quality remains good, even with the dark spots, which could occasionally occur molded plastics.
 - This product satisfies halogen free requirements defined as 900 ppm maximum chlorine, 900 ppm maximum bromine and 1500 ppm maximum total of chlorine and bromine.
 - 'n' represents the number of contacts.

4	Brass (Plated material)	Tin plating (reflow finished) 1μmMIN over copper 0.3μmMIN	8	(Connector)	
3	Copper alloy	(Contact area, lead) Gold plating 0.03μmMIN over nickel 1μmMIN (Other) Nickel plating 1μmMIN	7	Polystyrene	
2	PPS	Black UL94V-0	6	Polyester	
1	LCP	Gray UL94V-0	5	Polystyrene	
NO.	MATERIAL	FINISH . REMARKS	NO.	MATERIAL	FINISH . REMARKS
UNITS mm		SCALE 5 : 1	COUNT	DESCRIPTION OF REVISIONS	
DESIGNED		CHECKED		DATE	
APPROVED : HS. SAKAMOTO		17.02.15		DRAWING NO. EDC-371661-99-00	
CHECKED : HS. SAKAMOTO		17.02.15		PART NO. FH65-**S-0.5SH(99)	
DESIGNED : SG. MASAKI		17.02.14		CODE NO. CL580	
DRAWN : SG. MASAKI		17.02.14		1/8	

Aug.1.2018 Copyright 2018 HIROSE ELECTRIC CO., LTD. All Rights Reserved.
 In case that the application demands a high level of reliability, such as automotive,
 please contact a company representative for further information.

Recommended FPC/FFC (15:1)

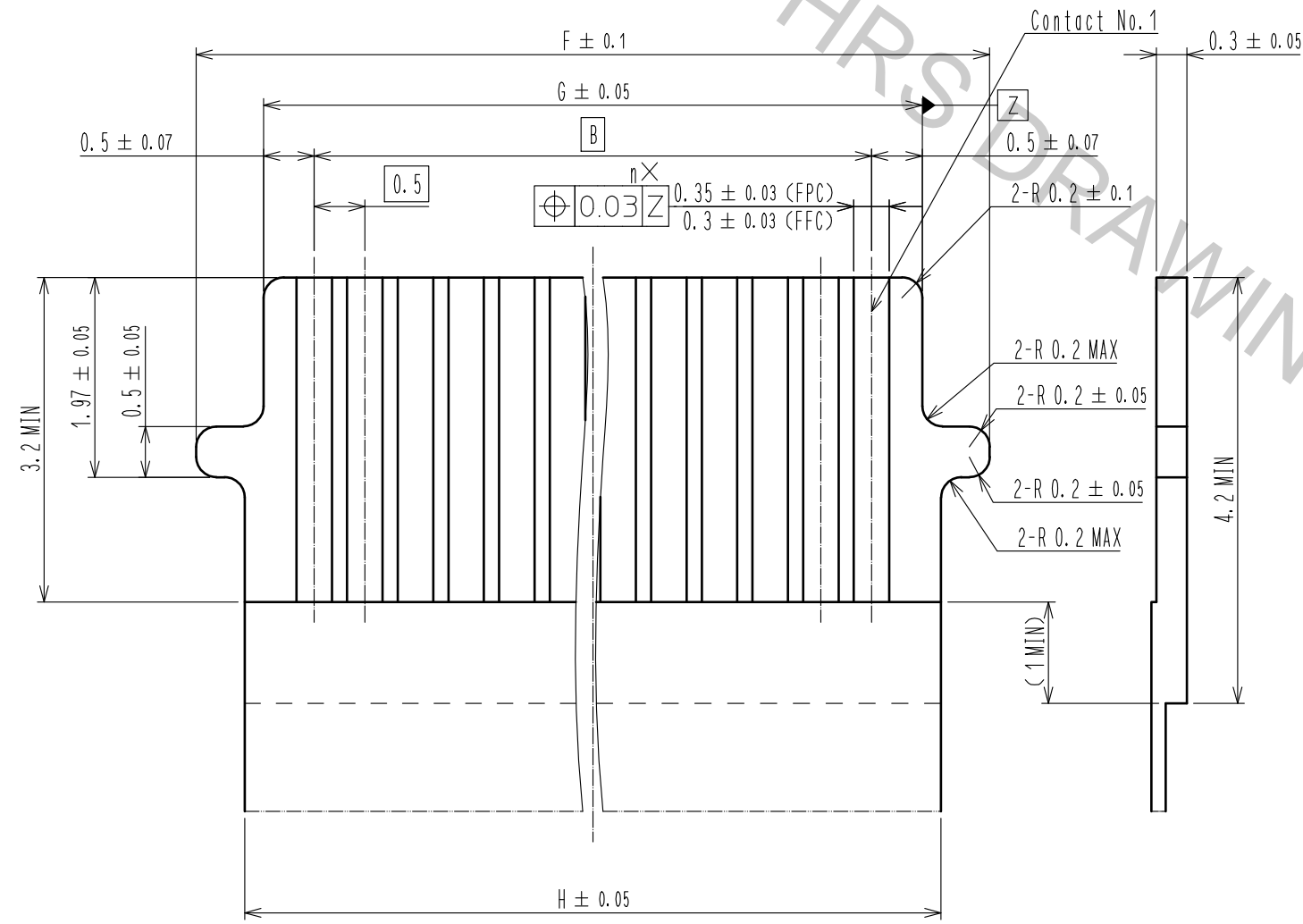

FPC configuration (reference example) (Scale: free)

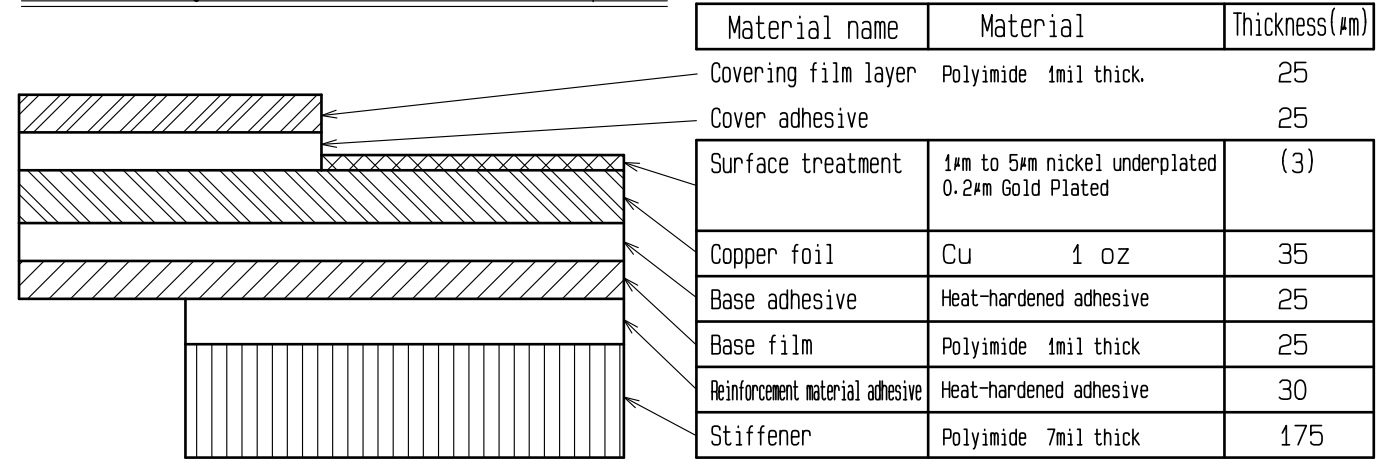

FFC configuration (reference example) (Scale: free)

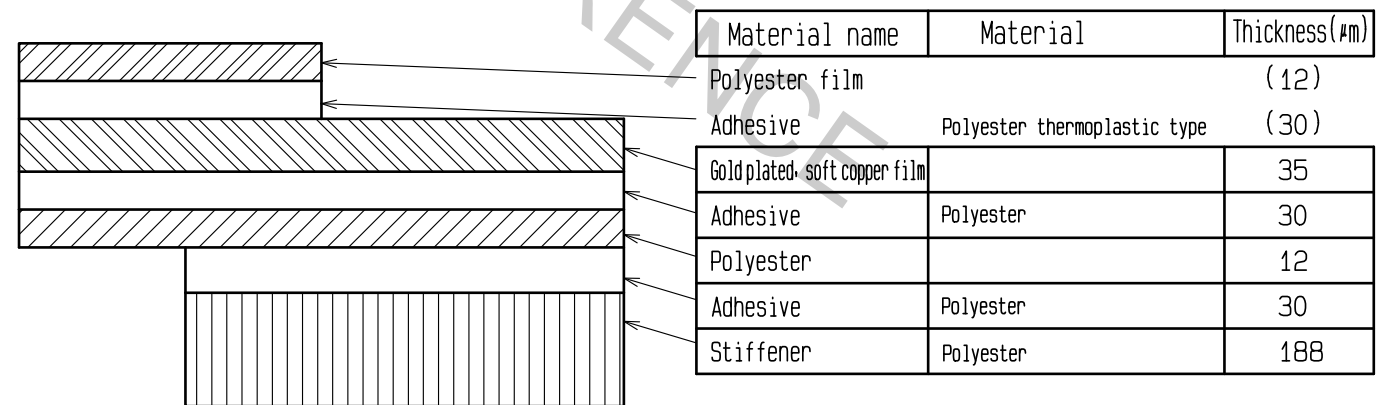

HRS	DRAWING NO.	EDC-371661-99-00
	PART NO.	FH65-**S-0.5SH(99)
	CODE NO.	CL580
		2/8

Embossed carrier tape dimensions (2:1)

Reel dimensions (no scale)

Tape width : 24mm MAX

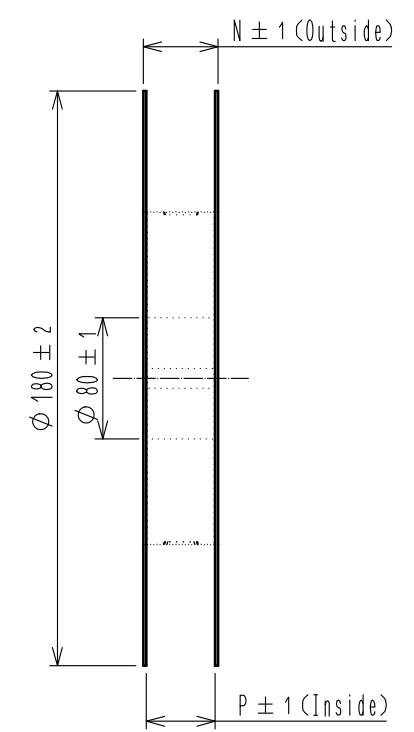
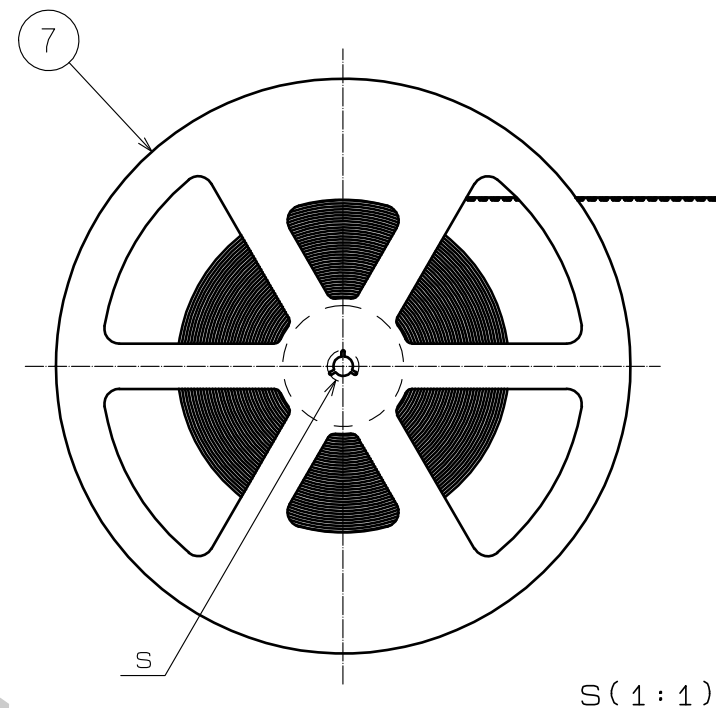
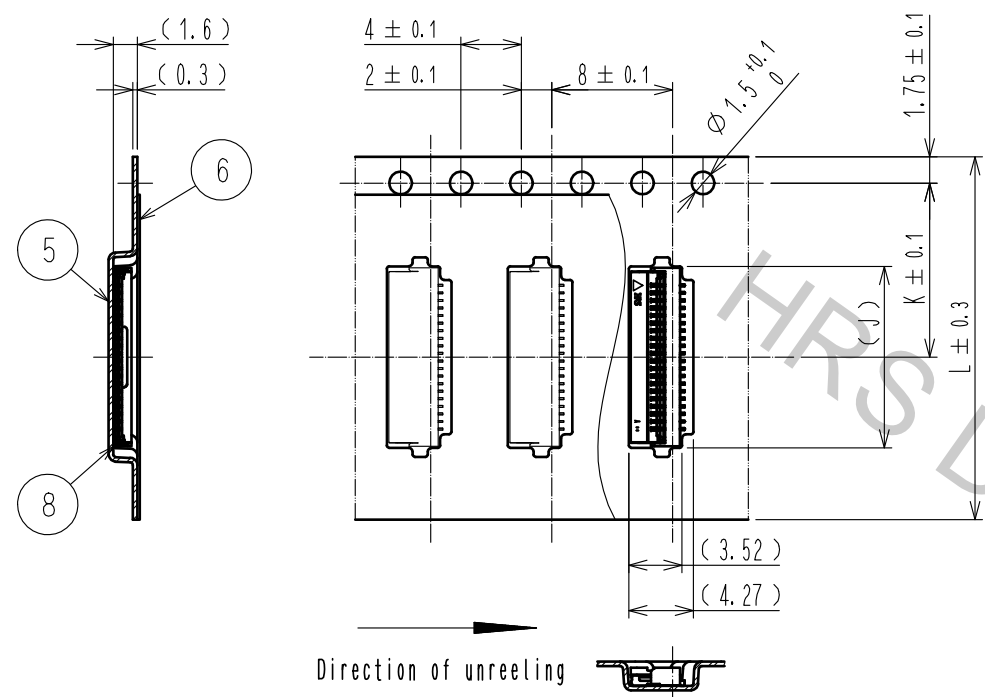

Tape width : 32mm MIN

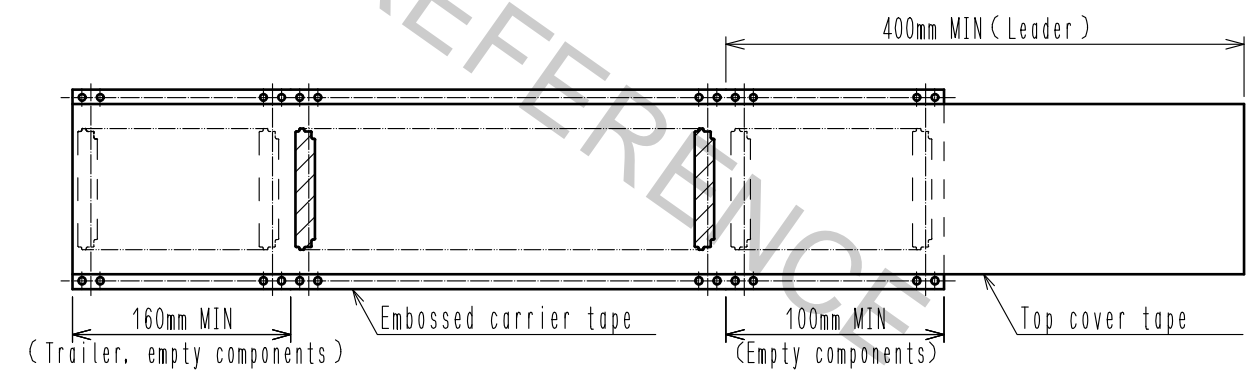
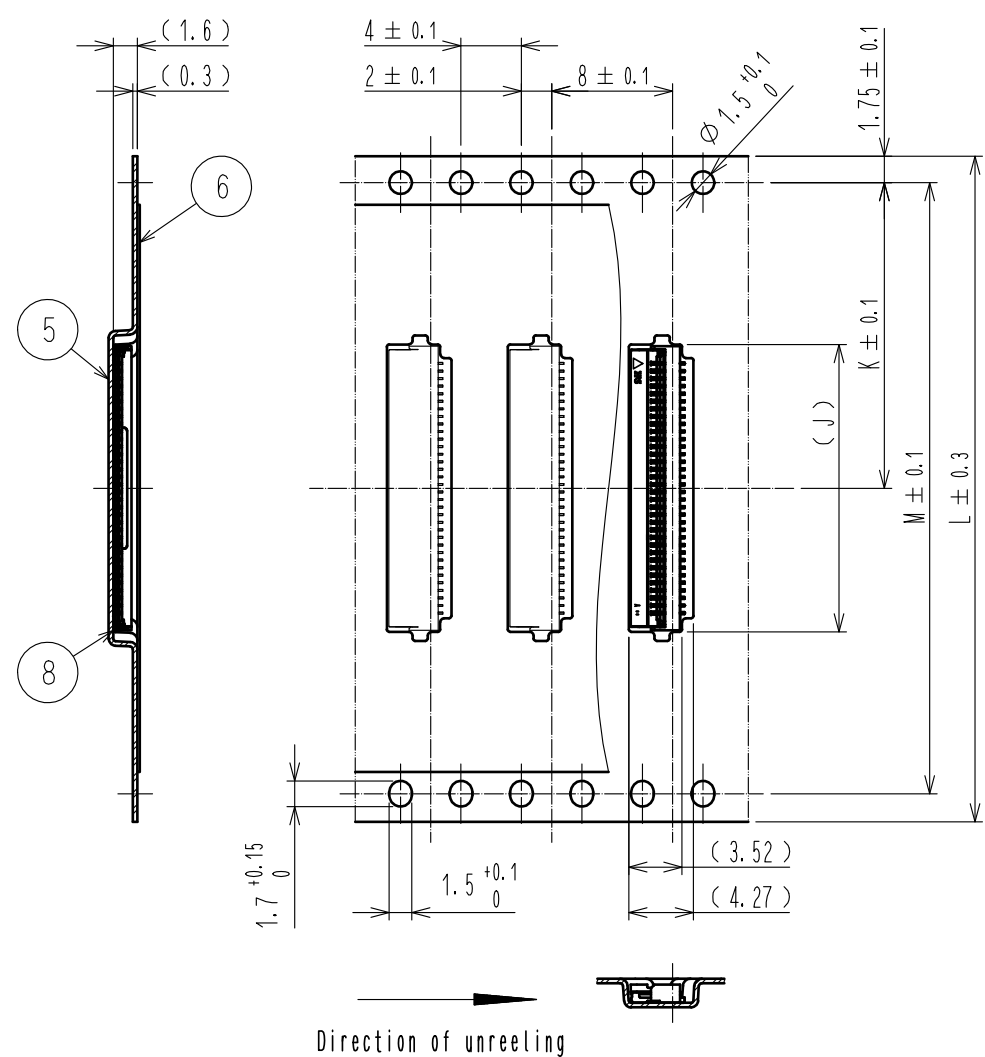

- NOTES 8. 1 reel : 500 connectors
9. Refer to JIS C 0806 (Packaging of components for automatic handling).

<PACKING SPECIFICATIONS>

HRS	DRAWING NO.	EDC-371661-99-00
	PART NO.	FH65-**S-0.5SH(99)
	CODE NO.	CL580
		3/8

Aug.1.2018 Copyright 2018 HIROSE ELECTRIC CO., LTD. All Rights Reserved.
In case that the application demands a high level of reliability, such as automotive, please contact a company representative for further information.

Part No.	Code No.	Number of contact	Dimension of connector, PCB mounting pattern, stencil pattern and FFC/FPC								Dimension of drawing for packing					
			A	B	C	D	E	F	G	H	J	K	L	M	N	P
FH65-4S-0.5SH(99)	————	4	3.8	1.5	2.57	3.18	2.8	3.83	2.5	2.87	4.0	7.5	16.0	—	21.4	17.4
FH65-6S-0.5SH(99)	————	6	4.8	2.5	3.57	4.18	3.8	4.83	3.5	3.87	5.0	7.5	16.0	—	21.4	17.4
FH65-8S-0.5SH(99)	————	8	5.8	3.5	4.57	5.18	4.8	5.83	4.5	4.87	6.0	7.5	16.0	—	21.4	17.4
FH65-10S-0.5SH(99)	————	10	6.8	4.5	5.57	6.18	5.8	6.83	5.5	5.87	7.0	11.5	24.0	—	29.4	25.4
FH65-12S-0.5SH(99)	————	12	7.8	5.5	6.57	7.18	6.8	7.83	6.5	6.87	8.0	11.5	24.0	—	29.4	25.4
FH65-14S-0.5SH(99)	————	14	8.8	6.5	7.57	8.18	7.8	8.83	7.5	7.87	9.0	11.5	24.0	—	29.4	25.4
FH65-15S-0.5SH(99)	————	15	9.3	7.0	8.07	8.68	8.3	9.33	8.0	8.37	9.5	11.5	24.0	—	29.4	25.4
FH65-16S-0.5SH(99)	————	16	9.8	7.5	8.57	9.18	8.8	9.83	8.5	8.87	10.0	11.5	24.0	—	29.4	25.4
FH65-18S-0.5SH(99)	————	18	10.8	8.5	9.57	10.18	9.8	10.83	9.5	9.87	11.0	11.5	24.0	—	29.4	25.4
FH65-20S-0.5SH(99)	————	20	11.8	9.5	10.57	11.18	10.8	11.83	10.5	10.87	12.0	11.5	24.0	—	29.4	25.4
FH65-22S-0.5SH(99)	————	22	12.8	10.5	11.57	12.18	11.8	12.83	11.5	11.87	13.0	11.5	24.0	—	29.4	25.4
FH65-24S-0.5SH(99)	————	24	13.8	11.5	12.57	13.18	12.8	13.83	12.5	12.87	14.0	11.5	24.0	—	29.4	25.4
FH65-26S-0.5SH(99)	————	26	14.8	12.5	13.57	14.18	13.8	14.83	13.5	13.87	15.0	14.2	32.0	28.4	37.4	33.4
FH65-28S-0.5SH(99)	————	28	15.8	13.5	14.57	15.18	14.8	15.83	14.5	14.87	16.0	14.2	32.0	28.4	37.4	33.4
FH65-30S-0.5SH(99)	————	30	16.8	14.5	15.57	16.18	15.8	16.83	15.5	15.87	17.0	14.2	32.0	28.4	37.4	33.4
FH65-32S-0.5SH(99)	————	32	17.8	15.5	16.57	17.18	16.8	17.83	16.5	16.87	18.0	14.2	32.0	28.4	37.4	33.4
FH65-34S-0.5SH(99)	CL580-4700-0-99	34	18.8	16.5	17.57	18.18	17.8	18.83	17.5	17.87	19.0	20.2	44.0	40.4	49.4	45.4
FH65-36S-0.5SH(99)	————	36	19.8	17.5	18.57	19.18	18.8	19.83	18.5	18.87	20.0	20.2	44.0	40.4	49.4	45.4
FH65-40S-0.5SH(99)	————	40	21.8	19.5	20.57	21.18	20.8	21.83	20.5	20.87	22.0	20.2	44.0	40.4	49.4	45.4
FH65-45S-0.5SH(99)	————	45	24.3	22.0	23.07	23.68	23.3	24.33	23.0	23.37	24.5	20.2	44.0	40.4	49.4	45.4
FH65-50S-0.5SH(99)	————	50	26.8	24.5	25.57	26.18	25.8	26.83	25.5	25.87	27.0	20.2	44.0	40.4	49.4	45.4
FH65-60S-0.5SH(99)	————	60	31.8	29.5	30.57	31.18	30.8	31.83	30.5	30.87	32.0	26.2	56.0	52.4	61.4	57.4
FH65-64S-0.5SH(99)	————	64	33.8	31.5	32.57	33.18	32.8	33.83	32.5	32.87	34.0	26.2	56.0	52.4	61.4	57.4
FH65-68S-0.5SH(99)	————	68	35.8	33.5	34.57	35.18	34.8	35.83	34.5	34.87	36.0	26.2	56.0	52.4	61.4	57.4

※Contact positions without code numbers are currently under planning.
 Please contact Hirose for detailed information about product variation.

HRS	DRAWING NO.	EDC-371661-99-00
	PART NO.	FH65-**S-0.5SH(99)
	CODE NO.	CL580
		4/8

Aug.1.2018 Copyright 2018 HIROSE ELECTRIC CO., LTD. All Rights Reserved.
In case that the application demands a high level of reliability, such as automotive, please contact a company representative for further information.

This connector features small and thin, requiring delicate and careful handling.
To prevent connector/FPC/FFC breakage and contact failure (mating failure, FPC/FFC pattern breakage, etc),
read through the instructions shown below and handle the connector properly.
Each values indicating here are for reference and may differ from standard value.

[Connector Part Nomenclature]

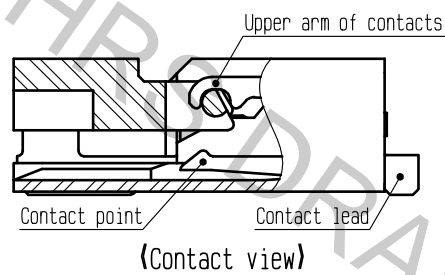
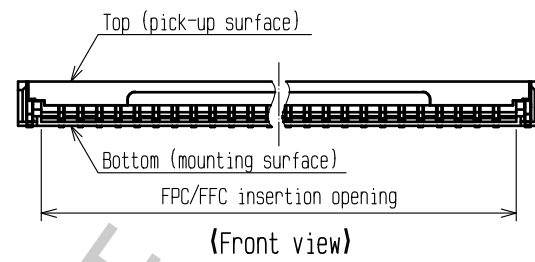
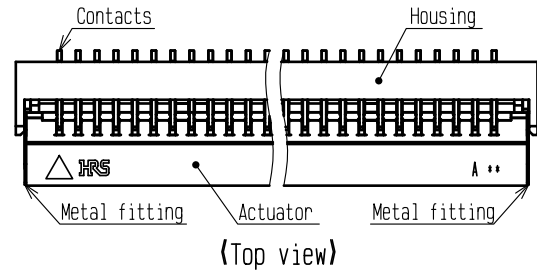

[Operation and Precautions]

1. Initial condition

The connector is delivered with the actuator closed.

[Caution]

-Do not insert FPC/FFC or operate actuator before mounting.

2. How to unlock (Before inserting FPC/FFC)

The actuator rotates on its axis as shown below.
Slowly flip up the actuator to release the lock.

[Caution]

- Open the actuator by carefully lifting it at the center.
- Do not lift the actuator at one end only.
- The actuator must be operated by hand only, and do not insert any tools or fingernails inside the connector.
- The actuator rotates 120 degrees max. Do not attempt to force the actuator to backside further.
- When operating the actuator do not apply any force in the direction of the connector.
- Do not attempt to dislodge the actuator.

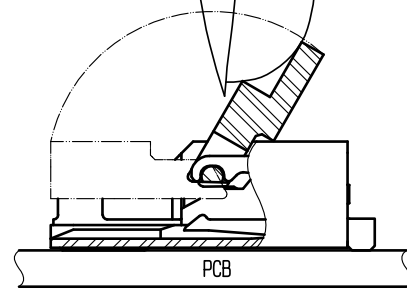
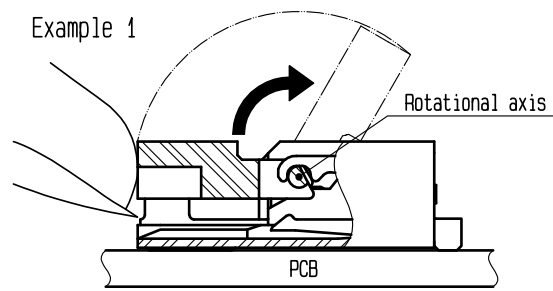

OK

- Correct operation -

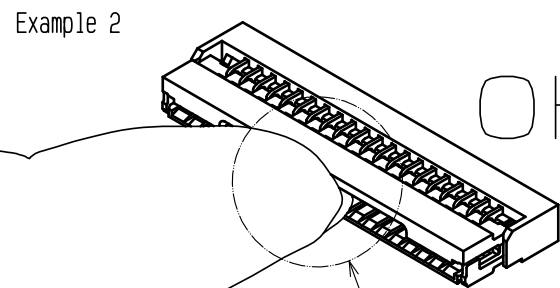

OK

Open the actuator at the center
- Correct operation -

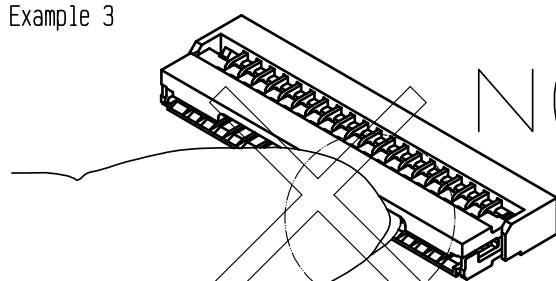

NG

Do not operate the actuator at one end only.

- Incorrect operation -

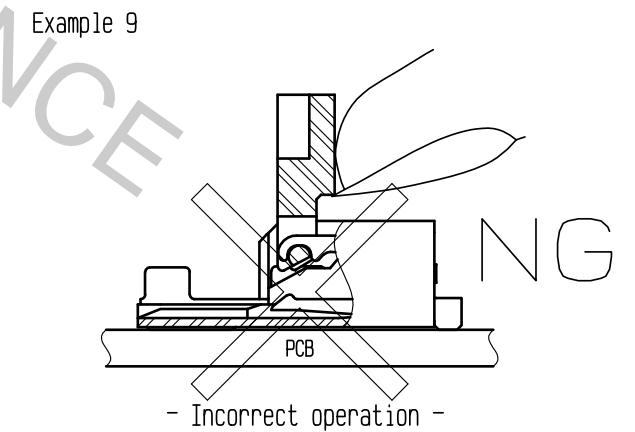
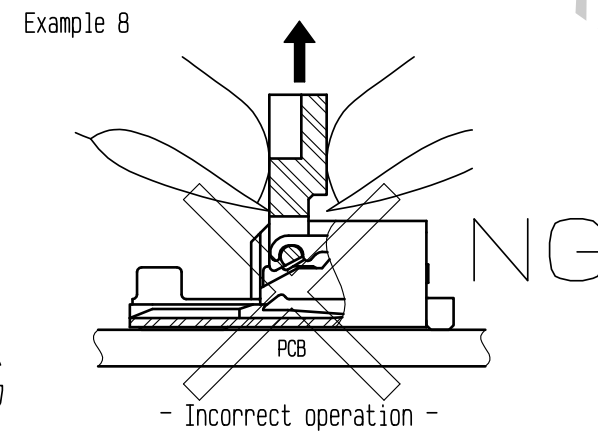
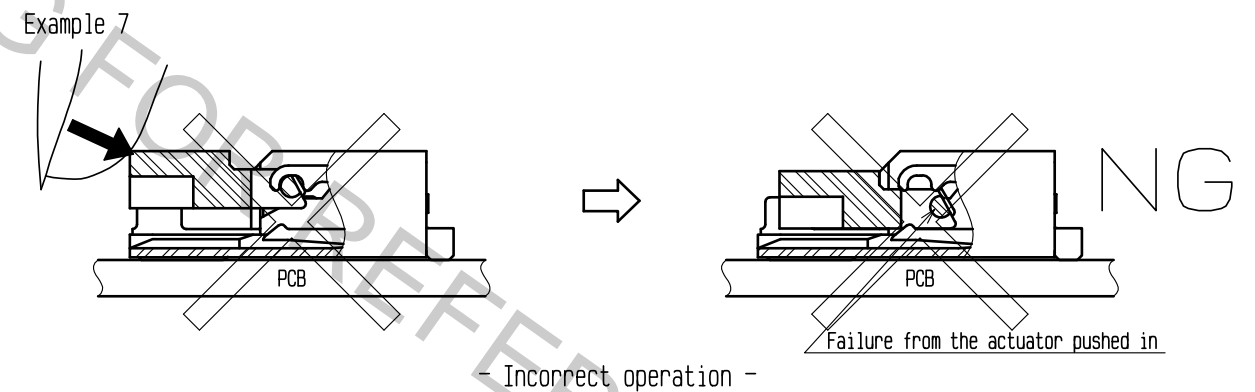
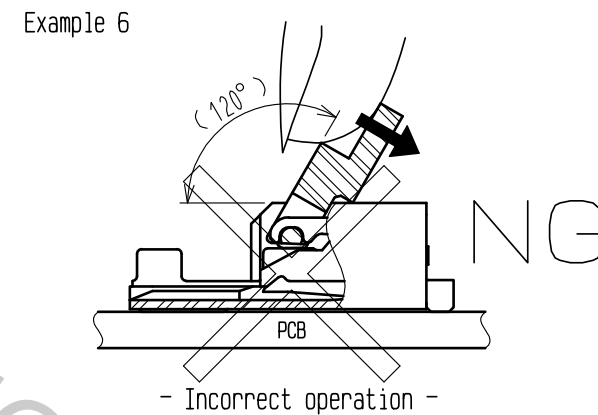
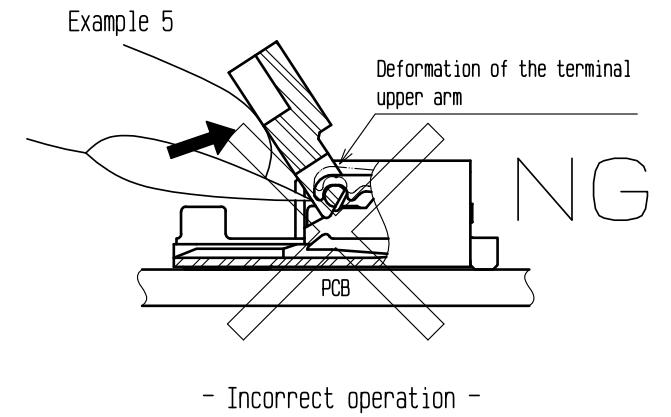
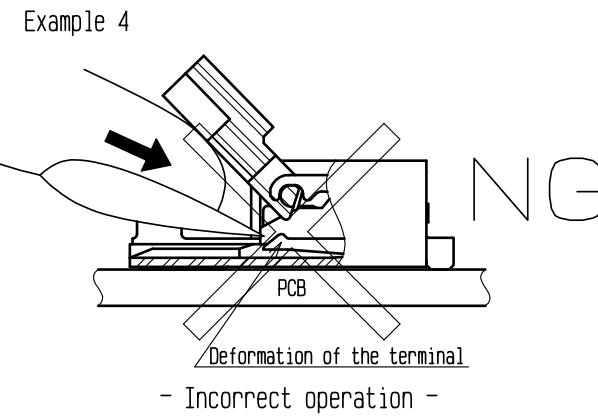

<INSTRUCTION MANUAL (1)>

HRS	DRAWING NO.	EDC-371661-99-00
	PART NO.	FH65-**S-0.5SH(99)
	CODE NO.	CL580
		5/8

Aug.1.2018 Copyright 2018 HIROSE ELECTRIC CO., LTD. All Rights Reserved.
 In case that the application demands a high level of reliability, such as automotive,
 please contact a company representative for further information.

3. How to insert FPC/FFC

This connector has contacts on the bottom, insert the FPC/FFC with the exposed conductors face down.
 This connector has metal fittings, insert the FPC/FFC at about 20 degree angle to the PCB mounting surface.

[Caution]

- Do not insert the FPC/FFC with the conductor surface face up.
- Insert the FPC/FFC properly to the very end.
- Do not insert the FPC/FFC at an angle.
- Insert the FPC/FFC with the actuator opened.
- Do not twist the FPC/FFC to up and down, right and left or an angle.

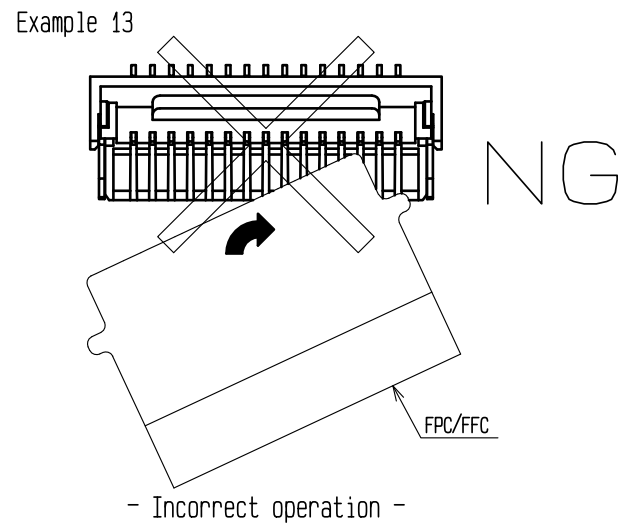
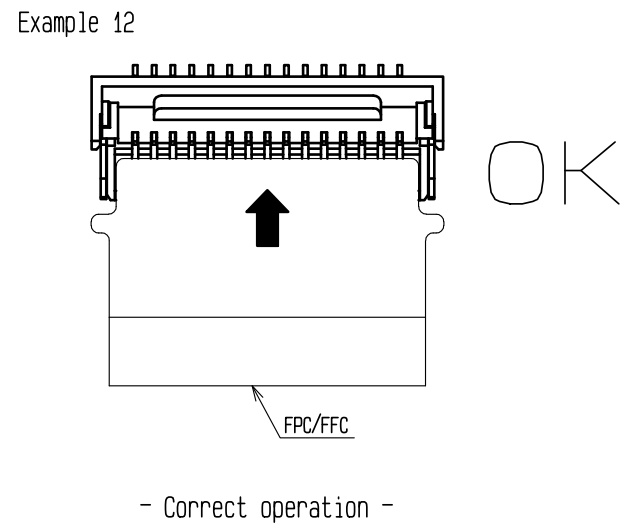
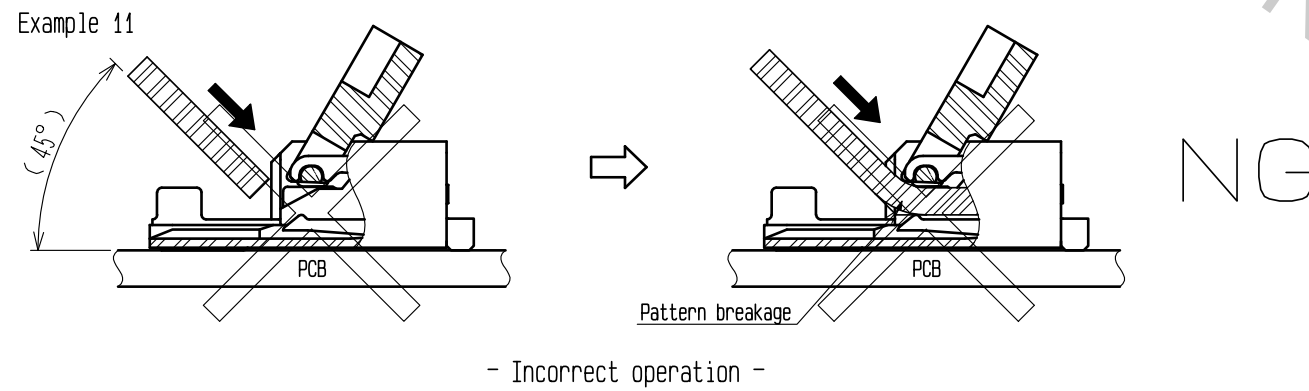
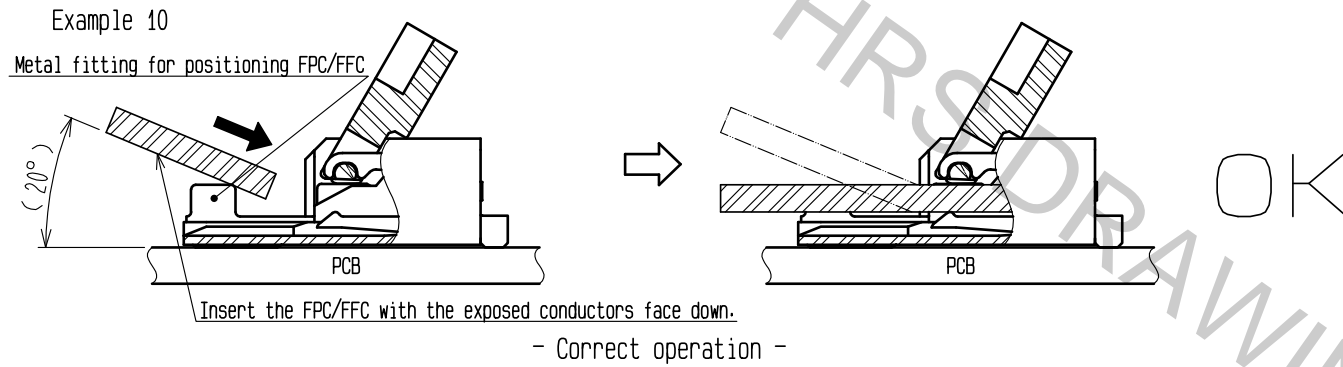

4. FPC/FFC insertion check

Metal fittings guide the FPC/FFC tabs to the correct position.
 Make sure that the FPC/FFC tabs are located in correct position as shown in the figure below after FPC/FFC insertion.

[Caution]

- Do not insert the FPC/FFC at an angle and/or stop it before insertion is completed.

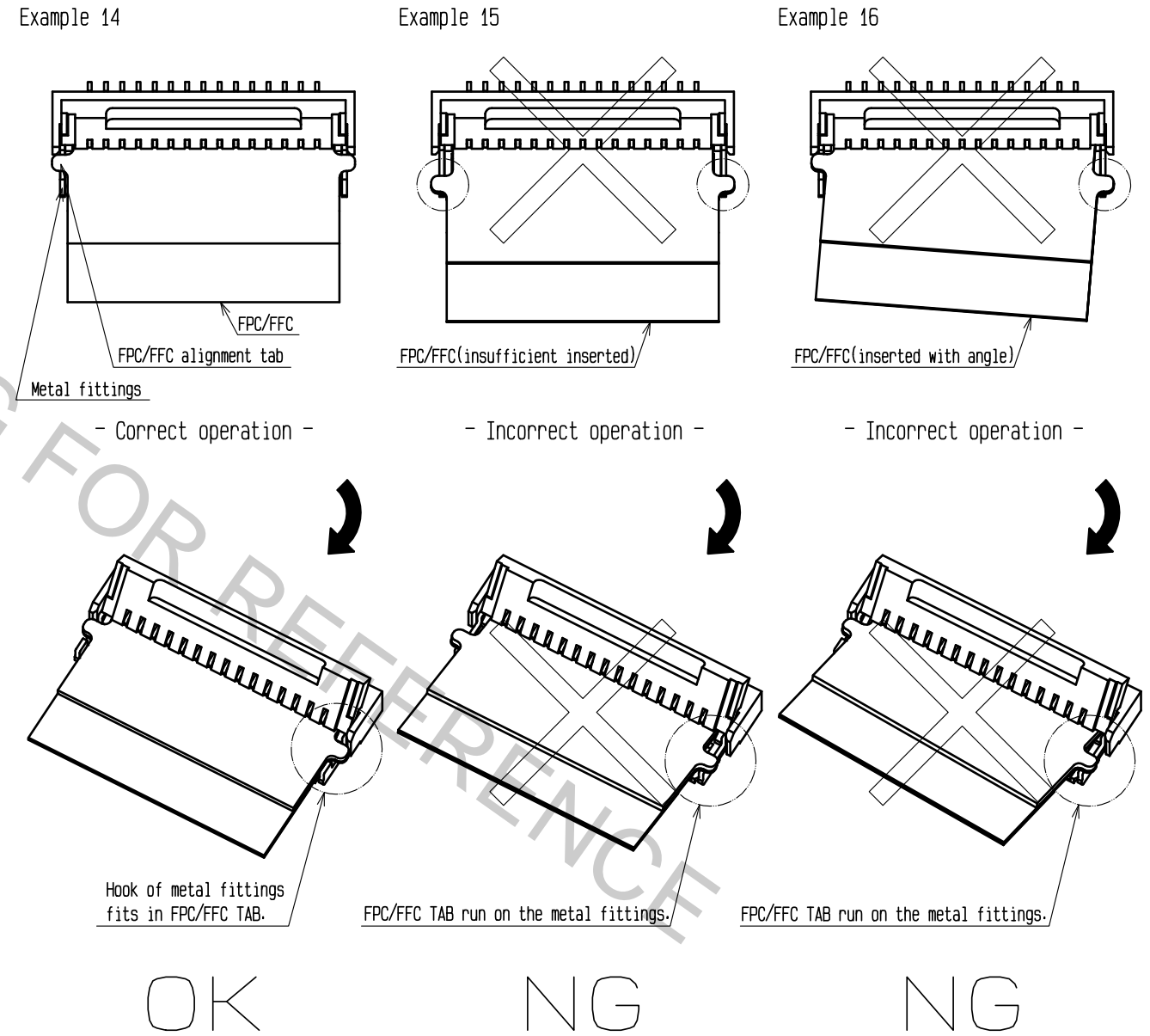

<INSTRUCTION MANUAL(2)>

HRS	DRAWING NO.	EDC-371661-99-00
	PART NO.	FH65-**S-0.5SH(99)
	CODE NO.	CL580
		6/8

Aug.1.2018 Copyright 2018 HIROSE ELECTRIC CO., LTD. All Rights Reserved.
In case that the application demands a high level of reliability, such as automotive, please contact a company representative for further information.

5. How to lock

The actuator rotates on its axis as shown below.
Apply load to rotate the actuator after inserting the FPC/FFC.

[Caution]

- Close the actuator by carefully operating it at the center.
- Do not operate the actuator at one end only.
- The actuator must be operated by hand only, and do not insert any tools or fingernails inside the connector.
- Do not attempt to force the actuator to backside further.
- Do not attempt to dislodge the actuator.
- Confirm that the actuator completely closed and is parallel to the PCB mounting surface.

Example 17

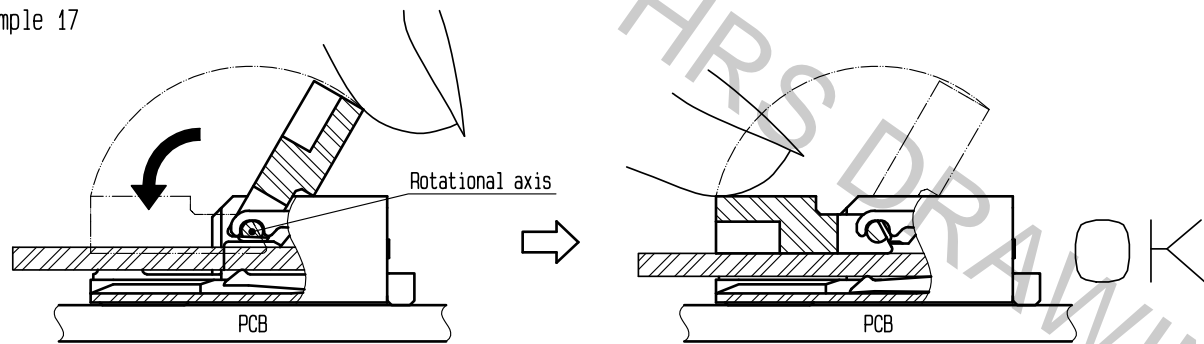

- Correct operation -

Example 18

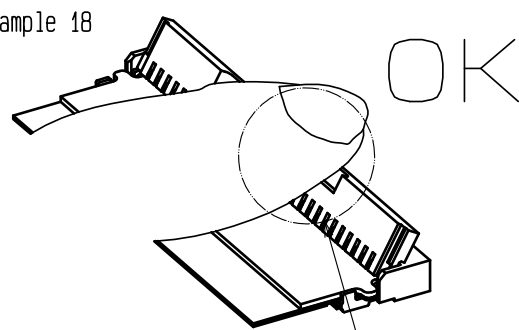

Close the actuator at the center
- Correct operation -

Example 19

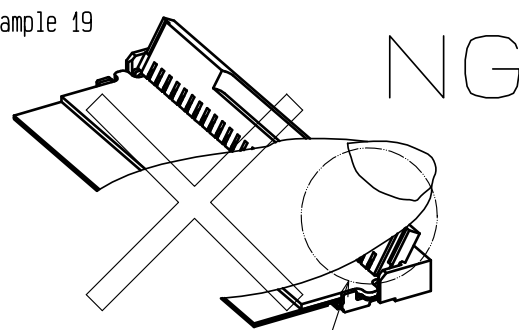

Do not operate the actuator
at one end only
- Incorrect operation -

7. How to unlock

Slowly flip up the actuator to release the lock.

[Caution]

- Open the actuator by carefully lifting it at the center.
- Do not lift the actuator at one end only.
- The actuator must be operated by hand only, and do not insert any tools or fingernails inside the connector.
- The actuator rotates 120 degrees max. Do not attempt to force the actuator to backside further.
- Do not attempt to dislodge the actuator.

Example 23

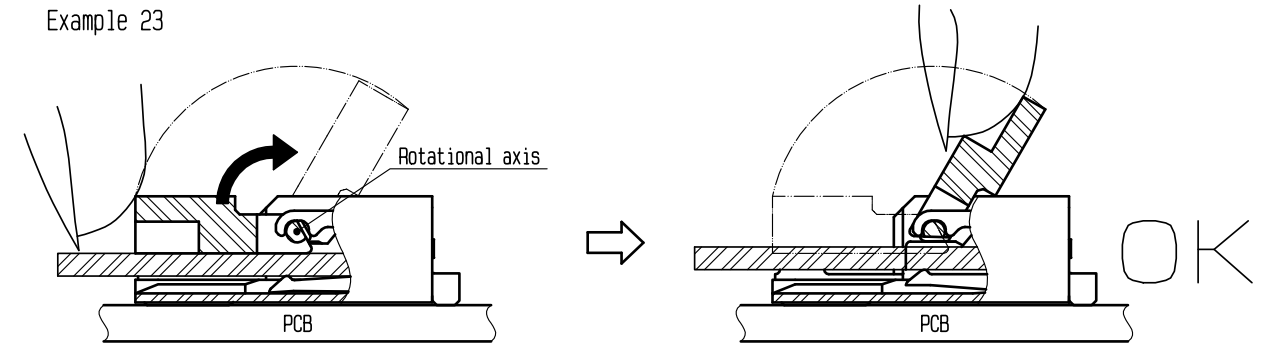

- Correct operation -

Example 24

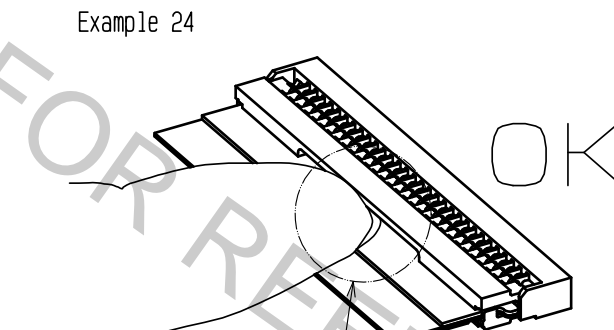

Close the actuator at the center
- Correct operation -

Example 25

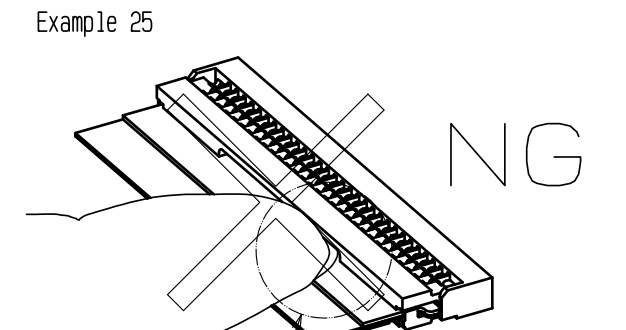

Do not operate the actuator
at one end only
- Incorrect operation -

6. Mating confirmation of the FPC/FFC

Visually confirm the FPC/FFC positioning after closing the actuator.

[Caution]

- Do not insert the FPC/FFC at an angle and/or stop it before insertion is completed.

Example 20

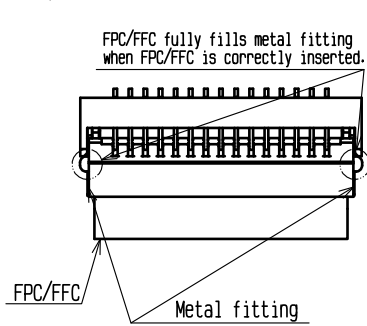

- Correct operation -

Example 21

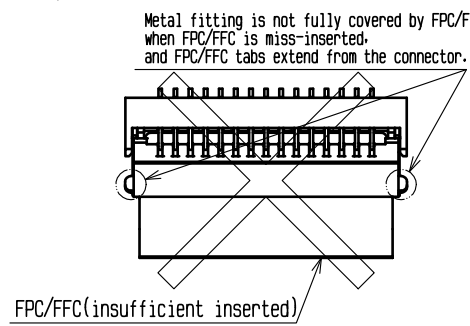

- Incorrect operation -

Example 22

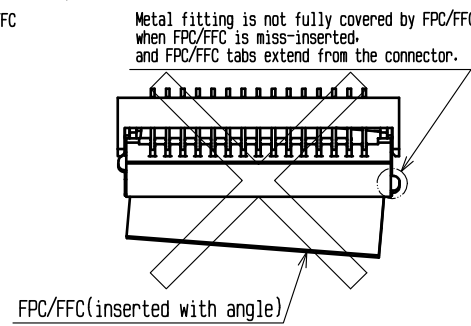

- Incorrect operation -

Example 26

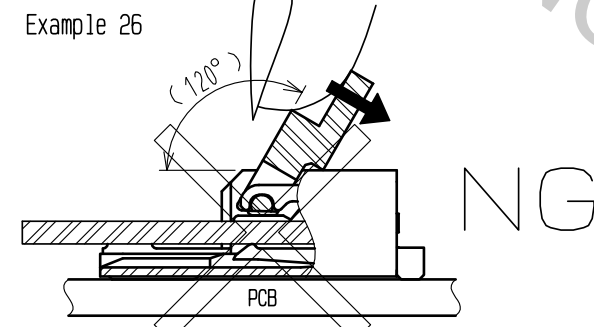

- Incorrect operation -

Example 27

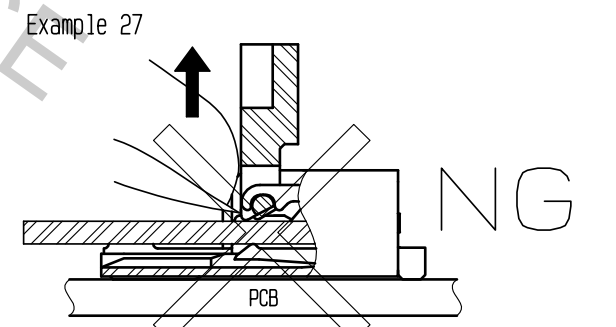

- Incorrect operation -

<INSTRUCTION MANUAL(3)>

HRS	DRAWING NO.	EDC-371661-99-00
	PART NO.	FH65-**S-0.5SH(99)
	CODE NO.	CL580
		7/8

8. How to remove FPC/FFC

This connector has a temporary FPC/FFC holding structure with metal fittings. After rotating the actuator to the fully opened position carefully withdraw the FPC/FFC pulling out at about 20 degree angle to the PCB mounting surface.

[Caution]

- For FPC/FFC removal, do not pull out the FPC/FFC horizontally.
- Do not withdraw the FPC/FFC at an angle.
- Do not attempt to pull the FPC/FFC without unlocking the actuator.

Example 28

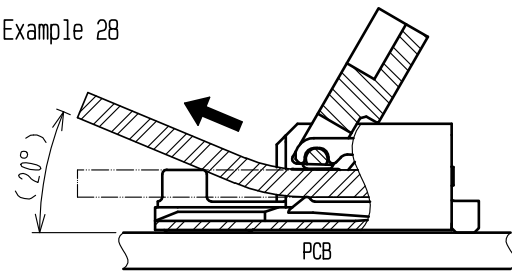

- Correct operation -

Example 29

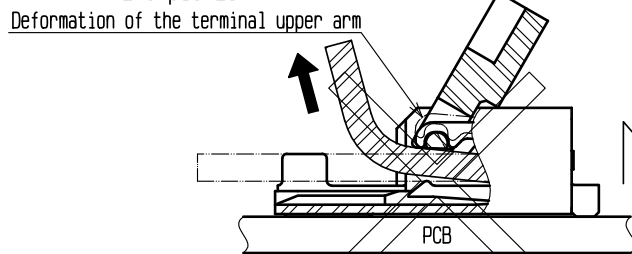

- Incorrect operation -

Example 30

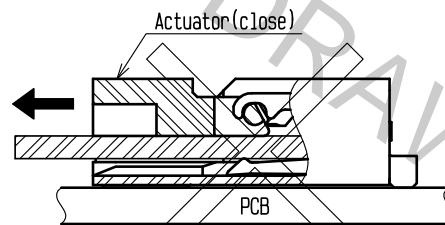

- Incorrect operation -

[Precautions for component layout]

Depending on a FPC/FFC rounding, a load is applied to the connector, and a contact failure may occur. To prevent a failure, take the following notes into a consideration during mechanism design.

[Caution]

- Avoid applying forces to FPC/FFC in vertical or horizontal directions. In addition, avoid pulling up and down on the FPC/FFC.
- When fixing FPC/FFC after FPC/FFC cabling, avoid pulling FPC/FFC, and route the wire FPC/FFC with slack. In this regard, the stiffener is parallel to the PCB.
- Do not bend the FPC/FFC excessively near the connector during use, or it may cause contact failure or FPC/FFC breakage. Fixing the FPC/FFC is recommended to prevent these failures.
- Do not mount other components touching to the FPC/FFC underneath the FPC/FFC stiffener.
- Follow the recommended FPC/FFC design. Make adjustments with the FPC/FFC manufacturer for FPC/FFC bending performance and wire breakage.
- Keep a sufficient FPC/FFC insertion space in the stage of the layout in order to avoid incorrect FPC/FFC insertion. Appropriate FPC/FFC length and component layout are recommended for assembly ease. Too short FPC/FFC length makes assembly difficult.
- Keep spaces for the actuator movement and its operation for PCB design and component layout.

Example 31

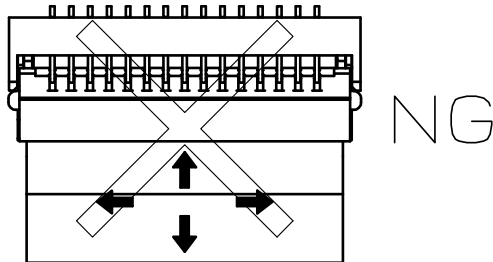

NG

Example 32

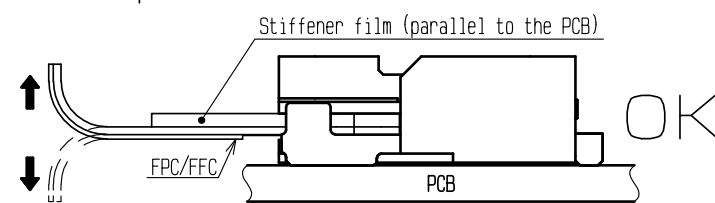

OK

Example 33

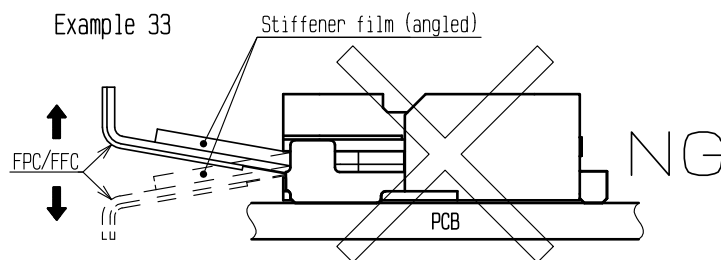

NG

Example 34

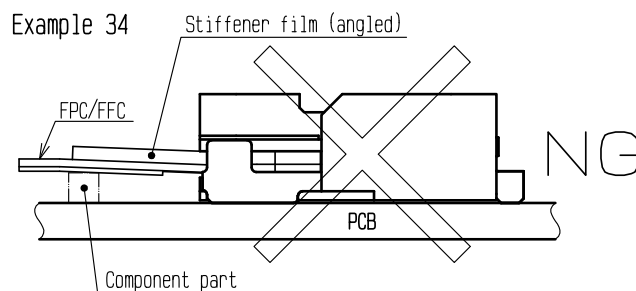

NG

[Instructions for mounting on the PCB]

Follow the instructions shown below when mounting on the PCB.

[Caution]

- Refer to recommended layouts on the page 1 for PCB and stencil pattern.
- Shorter pattern width than the recommended PCB dimension, could cause solder wicking and/or flux penetration.
- Larger pattern than the recommended stencil dimension, could cause solder wicking and/or flux penetration.
- Clearance underneath the contact and the housing is very small. In case solder resist and/or silk screening are applied on PCB underneath the connector, verify the thickness, or it could push up the connector bottom and may cause soldering defect and/or insufficient fillet formation.
- Apply reflow temperature profile within the specified conditions. In individual applications, the actual temperature may vary, depending on solder paste type, volume/thickness and PCB size/thickness. Consult your solder paste and equipment manufacturer for specific recommendations.
- Prevent warpage of PCB, where possible, since it can cause soldering failure :even with 0.1 mm max coplanarity.
- When mounting on the flexible board, please make sure to put a stiffener on the backside of the flexible board. We recommend a glass epoxy material with the thickness of 0.3 mm MIN.
- Do not add 1 N or greater external force when unreel or pick and place the connector etc, or it may get broken.

[Instructions for PCB handling after mounting the connector]

Follow the instructions shown below when mounting on the PCB.

[Caution]

- Splitting a large PCB into several pieces
 - Screwing the PCB
- Avoid the handling described above so that no force is exerted on the PCB during the assembly process. Otherwise, the connector may become defective.
- The warp of a 100 mm wide PCB should be 1 mm or less. The warp of PCB suffers stress on connector and the connector may become defective.

Example 35

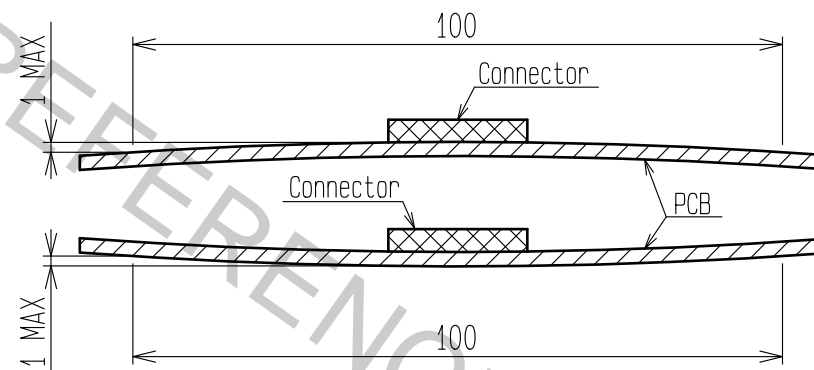

[Instructions on manual soldering]

Follow the instructions shown below when soldering the connector manually during repair work, etc.

[Caution]

- Do not perform manual soldering with the FPC/FFC inserted into the connector.
 - Do not heat the connector excessively. Be very careful not to let the soldering iron contact any parts other than connector leads. Otherwise, the connector may be deformed or melt.
 - Do not supply excessive solder (or flux).
- If excessive solder (or flux) is supplied on the terminals, solder or flux may adhere to the contacts or rotating parts of the actuator, resulting in poor contact or a rotation failure of the actuator. Supplying excessive solder to the metal fittings may hinder actuator rotation, resulting in breakage of the connector.

<INSTRUCTION MANUAL (4)>

HRS	DRAWING NO.	EDC-371661-99-00
	PART NO.	FH65-**S-0.5SH(99)
	CODE NO.	CL580
		8/8

Aug.1.2018 Copyright 2018 HIROSE ELECTRIC CO., LTD. All Rights Reserved. In case that the application demands a high level of reliability, such as automotive, please contact a company representative for further information.