

ATLANTIC VERSION TERMINATOR INTERFACE ADAPTER	PART NUMBER	REVISION	DESCRIPTION	FEED TYPE	CONVERT TO	PART NUMBERS REQUIRED					
	2150385-1	A	FINE CRIMP HEIGHT ADJUST	MECHANICAL	PNEUMATIC FEED	2119950-1	2119792-2	-	2119641-1	-	2063440-1
					SERVO LATCH PLATE	2119951-1	1901697-1	8-2150385-5	-	-	2168400-7 (QUANTITY 2)
					SMART APPLICATOR	2161326-1	-	8-2150385-4	-	-	-
	2150385-2	A	FINE CRIMP HEIGHT ADJUST	PNEUMATIC	MECHANICAL FEED	2119949-1	2063961-1	5-18022-5	2119653-1	-	-
					SERVO LATCH PLATE	2119951-1	1901697-1	8-2150385-5	-	-	2168400-7 (QUANTITY 2)
					SMART APPLICATOR	2161326-1	-	8-2150385-4	-	-	-
	2150385-5	A	FINE CRIMP HEIGHT ADJUST	SERVO LATCH PLATE	MECHANICAL FEED	2119949-1	2063961-1	5-18022-5	2119653-1	-	-
				PNEUMATIC FEED	2119950-1	2119792-2	-	2119641-1	-	2063440-1	
2150385-6	A	NON-CRIMP HEIGHT ADJUST	SERVO LATCH PLATE	-	-	-	-	-	-	-	
2150385-7	A	FINE CRIMP HEIGHT ADJUST	NONE	-	-	-	-	-	-	-	
7-2150385-7	A	CRIMP TOOLING KIT	-	-	-	-	-	-	-	-	

APPLICATOR DATA		
CRIMP	SIZE	TYPE
WIRE	2.03 mm [.080]	F
INSUL	3.56 mm [.140]	F
APPL INSTRUCTIONS 408-10390		

TERMINAL DATA: TE TERMINAL TE CRIMP SPECIFICATION	
TERMINAL NAME: RECEPTACLE, SHUR PLUG	
WIRE STRIP LENGTH 3.66-4.26 mm [.144-.168 IN]	INSULATION DIAMETER RANGE Ø2.16-3.18 mm [.085-.125 IN]
TERMINAL APPLICATION SPECIFICATION 114-2042	-
TERMINALS APPLIED	
TE TERMINAL 42581-2	TE TERMINAL

WIRE SIZE	CRIMP HEIGHT mm [INCH]	CRIMP HEIGHT REFERENCE SETTING
18 AWG	1.52+/-0.05 [.060+/- .002]	7.0
20 AWG	1.40+/-0.05 [.055+/- .002]	8.2
22 AWG	1.35+/-0.05 [.053+/- .002]	8.7

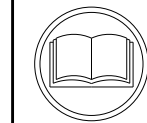

- 1 RECOMMENDED SPARE PARTS
- 2 GREASE BEARING SURFACES LIGHTLY
- 3 LUBRICATE DAILY PER THE APPLICATOR INSTRUCTION SHEET SUPPLIED WITH THE APPLICATOR.
- 4 APPLICATOR SPECIFIC DATA TO BE ENTERED INTO BLANK MEMORY CHIP AT ASSEMBLY. SEE BELOW FOR PART NUMBER:
 MECHANICAL FEED WITH "SMART APPLICATOR" CONVERSION: 8-2150385-4
 PNEUMATIC FEED WITH "SMART APPLICATOR" CONVERSION: 8-2150385-4
 SERVO FEED WITH "FINE CRIMP HEIGHT ADJUST": 8-2150385-5
 SERVO FEED WITH "NON-CRIMP HEIGHT ADJUST": 8-2150385-6
- 5 ADJUSTMENT OF THE STRIPPER MAY BE REQUIRED WHEN MOVING THE APPLICATOR BETWEEN BENCH AND LEADMAKER APPLICATIONS.
- 6 APPLY PART NUMBER 1-23419-5 LOCTITE TO THREADS OF ITEMS 50, 62 & 242. FOR -6 ONLY APPLY PART NUMBER 1-23419-5 LOCTITE TO THREADS OF ITEMS 37, 50 & 242.
- 7 GREASE THREADS, GROOVE AND O-RING ON ITEMS 35 & 252.
- 8 MAGNET, ITEM 166 MUST BE ORIENTED CORRECTLY IN ORDER TO PROPERLY ACTUATE THE COUNTER.
- 9 CRIMP HEIGHT REFERENCE SETTING WAS THE SETTING USED WHEN THE APPLICATOR WAS QUALIFIED AT THE FACTORY. ADJUSTMENT MAY BE NECESSARY WHEN RUNNING APPLICATOR IN THE FIELD.
- 10 SPARE FEED CAM STORAGE LOCATION REFER TO INSTRUCTION SHEET FOR ADDITIONAL INFORMATION.
- 11 THE RECOMMENDED SET-UP FOR END FEED APPLICATORS IS POST-FEED WITH ITEM 2119653-1. THE APPLICATOR CAN BE CONFIGURED FOR PRE-FEED WITH ITEM 2119652-1 BUT MAY ENCOUNTER PROBLEMS WITH SOME APPLICATIONS. FEED ISSUES OR TERMINAL JAMMING MAY OCCUR IN THE PRE-FEED CONFIGURATION.
- 12 WHEN ASSEMBLING -6 NON-CRIMP HEIGHT ADJUST APPLICATOR USE SHIM PACK 2119957-2 TO ALIGN APPLICATOR'S MAXIMUM WIRE CRIMP HEIGHT AT NORMAL TERMINATOR SHUT HEIGHT

***WARNING**
 ON INSTALLATION, SET WIRE DISC, ITEM 40 TO LARGEST WIRE SIZE SETTING. USE OF SETTINGS BELOW MINIMUM REQUIRED CRIMP HEIGHT SETTING WILL CAUSE DAMAGE TO CRIMP TOOLING.

-77	-7	-6	-5	-2	-1	PART NO	DESCRIPTION	ITEM NO
-	-	1	-	-	-	2119957-2	APPLICATOR SHIM PACK	260
-	1	-	1	1	1	8-21084-0	O-RING, .676 ID, .070 DIA. MAT.	252
-	-	-	-	1	-	2119640-1	PUSH ROD, AIR FEED	250
-	-	-	-	1	-	2079988-1	BUSHING, LCH5-12, MISUMI	249
-	-	-	-	1	-	2119641-1	FEED CAM, AIR FEED	248
-	1	-	1	1	1	2119798-1	DETENT PIN	247
-	1	-	1	1	1	1-22279-3	SPRING, COMPRESSION	246
-	-	1	-	-	-	2119759-1	RAM, AMP STYLE, END FEED, NON-ADJUST	245
-	1	1	1	1	1	2119082-7	CAM, SNAIL, INSULATION ADJUSTMENT	244
-	1	1	1	1	1	2079764-1	WASHER, WAVE SPRING, CREST-TO-CREST	243
-	1	1	1	1	1	2119083-1	RETAINER, INSULATION DIAL	242

ATLANTIC VERSION
 Shown on sheets 1 of 4 & 2 of 4
 (Pacific version shown on sheets 3 of 4 & 4 of 4)

SET UP GAUGE	LOC	DIST	REVISIONS			
2119599-2	A	66	REV	DATE	BY	APPV
			A	RELEASED		03DEC2013 LG TE

REV	DATE	BY	APPV	DESCRIPTION	DATE	OWN	APPV	
-	-	2	2	-	-	2168400-7	SHCS, LOW HEAD, RoHS, M5 X 10	240
-	-	-	-	-	1	2119580-1	MECHANICAL FEED ASSEMBLY	239
-	-	-	-	-	1	2063440-1	AIR FEED MODULE	238
-	-	1	1	-	-	2119740-2	TAG, IDENTIFICATION	213
-	-	REF	REF	-	-	1901697-1	FEED FINGER ASSEMBLY, EF	183
-	1	1	1	1	1	6-993111-6	PIN, SLOTTED SPRING 3.0 X 14.0	177
-	1	1	1	1	1	8-22280-7	SPRING, COMPRESSION	176
-	1	1	1	1	1	1752353-2	GUIDE PIN, HOLDDOWN	175
-	1	1	1	1	1	1901680-2	GUIDE PIN, HOLDDOWN	174
-	-	-	-	2	-	21045-3	RING, RETAIN, EXTERN, 3/16 CRESCENT	172
-	1	1	1	1	1	994969-1	MAGNET, RARE EARTH HIGH ENERGY	166
-	REF	REF	REF	REF	REF	994970-2	COUNTER, MAGNETIC	164
-	-	-	-	-	1	240638-1	SPRING, FEED FINGER	163
-	-	-	-	-	1	3-23627-7	PIN, RETAIN, GRVD, 3/16 X .854	137
-	-	REF	REF	-	-	SEE NOTE 4	MEMORY CHIP, PROGRAMMED	135
-	-	1	1	-	-	1633743-1	SERVO FEED LATCH ASM	133
-	1	1	1	1	1	455888-5	SPACER, CRIMPER	82
-	1	1	1	1	1	2119791-9	DEPRESSOR, WIRE	73
-	1	1	1	1	1	2119956-2	DOCUMENTATION PACKAGE	71
-	2	2	2	2	2	2-18032-2	SCR, SET, FLT POINT M3 X 10.0	70
-	1	1	1	1	1	2119943-1	WASHER, SPACER	69
-	1	-	-	1	1	2119740-1	TAG, IDENTIFICATION	67
-	2	2	2	2	2	2168078-1	SCREW, DRIVE, RH, RoHS, 2 x .188	66
-	1	1	1	1	1	1901681-1	HOLDDOWN, TERMINAL	65
-	2	2	2	2	2	2168400-5	SHCS, LOW HEAD, RoHS, M4 X 20	64
-	1	-	1	1	1	2119793-1	LIMITER, ADJUSTMENT BOLT	63
-	3	-	3	3	3	992763-5	SCR, SET, SOC, CONE POINT, M3 X 4.0	62
-	1	1	1	1	1	2079383-4	SCR, BHSC, RoHS (M4 X 8)	60
-	-	-	-	-	1	5-18022-5	SCR, HEX HD CAP, M4 X 6.0	59
-	-	-	-	-	1	2063961-1	FEED FINGER	58
-	3	3	3	3	3	2168400-4	SHCS, LOW HEAD, RoHS, M4 X 8	57
-	2	2	2	2	2	1-2168083-0	SCR, SKT HD CAP, RoHS, M4 X 10	56
-	2	2	2	2	2	5018030-2	NUT, HEX, REG, RoHS, M4	55
-	2	2	2	2	2	5018030-1	NUT, HEX, REG, RoHS, M3	54
-	2	2	2	2	2	986965-8	NUT, LOCK, HEX, TORQUE (M4)	53
-	1	1	1	1	1	1-5018030-0	NUT, HEX, REG, RoHS, M3.5	52
-	-	-	-	-	1	2119792-2	PAWL, EF, AIR	51
-	1	1	1	1	1	1-1976055-6	STANDOFF, HOLD-DOWN	50
-	-	-	-	-	1	18023-9	SCR, SKT HD CAP M4 X 6.0	49
-	-	-	-	-	1	2119652-1	FEED CAM, PRE FEED	48
-	-	-	-	-	1	2119653-1	FEED CAM, POST FEED	47
-	1	1	1	1	1	2119655-5	APPLICATOR BASIC ASSEMBLY, EF	46
-	1	-	1	1	1	2119369-1	RAM, AMP STYLE, END FEED	44
-	1	1	1	1	1	2079383-7	SCR, BHSC, RoHS (M8 X 25)	41
-	1	-	1	1	1	2119645-1	DISC, NUMBERED FA WIRE ADJUSTMENT	40
-	1	-	1	1	1	2119957-1	APPLICATOR SHIM PACK	39
-	1	1	1	1	1	1-2119644-2	RAM WASHER, PRECISION	38
-	1	1	1	1	1	2119085-1	FA HEAD, ATLANTIC STYLE	37
-	1	-	1	1	1	2119092-1	BOLT, ADJUSTMENT	35
-	7	7	7	7	7	1-18028-2	WASHER, FLAT, REG M4	33
-	2	2	2	2	2	2168083-9	SCR, SKT HD CAP, RoHS, M4 X 20	31
-	2	2	2	2	2	1-2168083-0	SCR, SKT HD CAP, RoHS, M4 X 10	29
-	1	1	1	1	1	455888-4	SPACER, CRIMPER	28
-	1	1	1	1	1	240639-1	STRIPPER (MACHINING)	27
-	2	2	2	2	2	1320906-1	STUD, THREADED	25
-	1	1	1	1	1	1752371-1	PLATE, STRIP GUIDE	24
-	1	1	1	1	1	240825-1	PLATE, STRIP HOLD DOWN	23
-	2	2	2	2	2	2-22281-3	SPRING, COMPRESSION	22
-	1	1	1	1	1	1752373-4	DRAG	20
-	2	2	2	2	2	1901259-6	GUIDE, LOWER STRIP	18
-	4	4	4	4	4	1-2079383-1	SCR, BHSC, RoHS (M6 X 12)	17
-	1	1	1	1	1	3-240641-7	SPACER	16
-	1	1	1	1	1	240644-1	PLATE, REAR SHEAR	11
-	-	-	-	-	-	-	-	10
-	1	1	1	1	1	690482-4	PLATE, FRONT SHEAR	9
-	1	1	1	1	1	1333216-5	ANVIL, COMBINATION	8
-	1	1	1	1	1	1-2217206-0	BLADE, SLUG	7
-	-	-	-	-	-	-	-	6
-	1	1	1	1	1	240641-7	SPACER	5
-	1	1	1	1	1	238009-1	BLOCK, FL CRIMPER SPACER	4
-	1	1	1	1	1	2-1633961-3	CRIMPER, INSULATION F PREMIUM	3
-	1	1	1	1	1	455888-3	SPACER, CRIMPER	2
-	1	1	1	1	1	1-456405-5	CRIMPER, WIRE PREMIUM	1

DIMENSIONS:	TOLERANCES UNLESS OTHERWISE SPECIFIED:	DRAWN	DATE	CHK	DATE	APPR	DATE	NAME	SIZE	CAGE CODE	DRAWING NO	RESTRICTED TO
mm	0 PLC ±.015 1 PLC ±.013 5 PLC ±.013 4 PLC ±.0001 ANGLES ±.0001	Y. YIN	21OCT2013	G. BAILEY	21OCT2013	U. GUO	21OCT2013	TE Connectivity Harrisburg, PA 17105-3608	A	00779	©=2150385	-
MATERIAL:	FINISH:	Customer Accessible Production Drawing		SCALE 1:1		SHEET 1 OF 4		REV A				

LOC		DIST		REVISIONS			
A	66	P	LTM	DESCRIPTION	DATE	DWN	APVD
		-	-	SEE SHEET 1	-	-	-

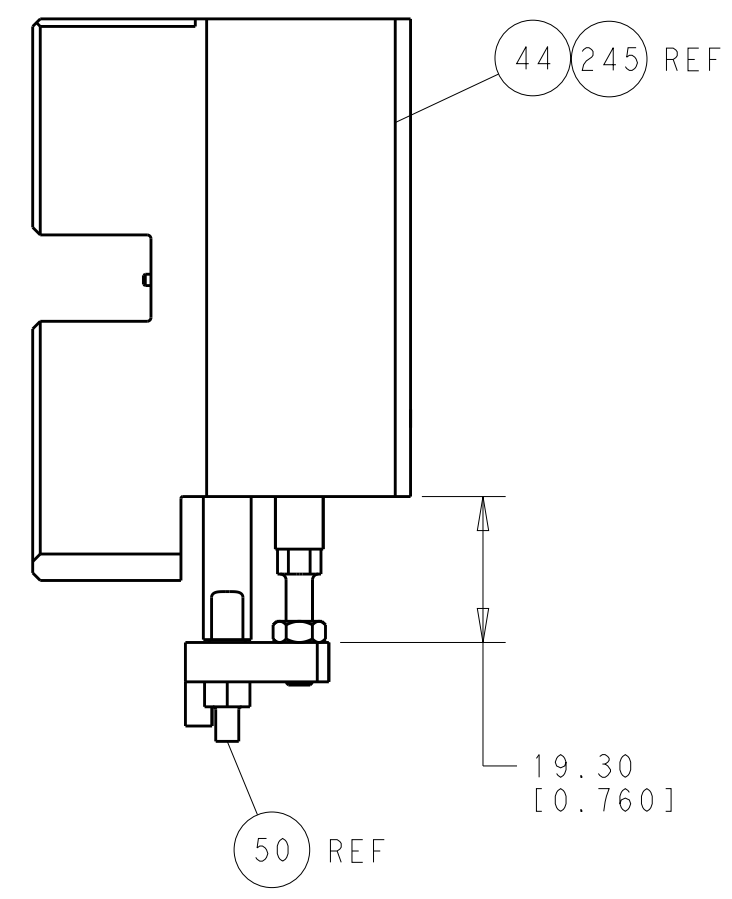

HOLDDOWN SET-UP

FEED TYPE
MECHANICAL

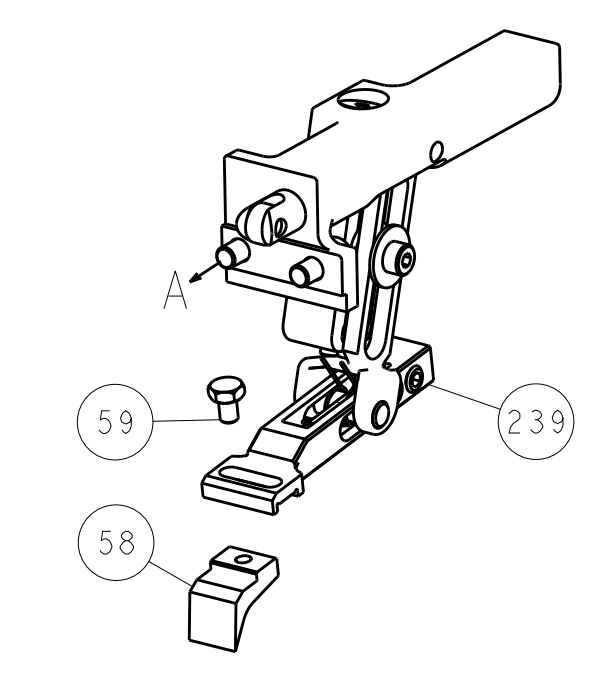

PNEUMATIC

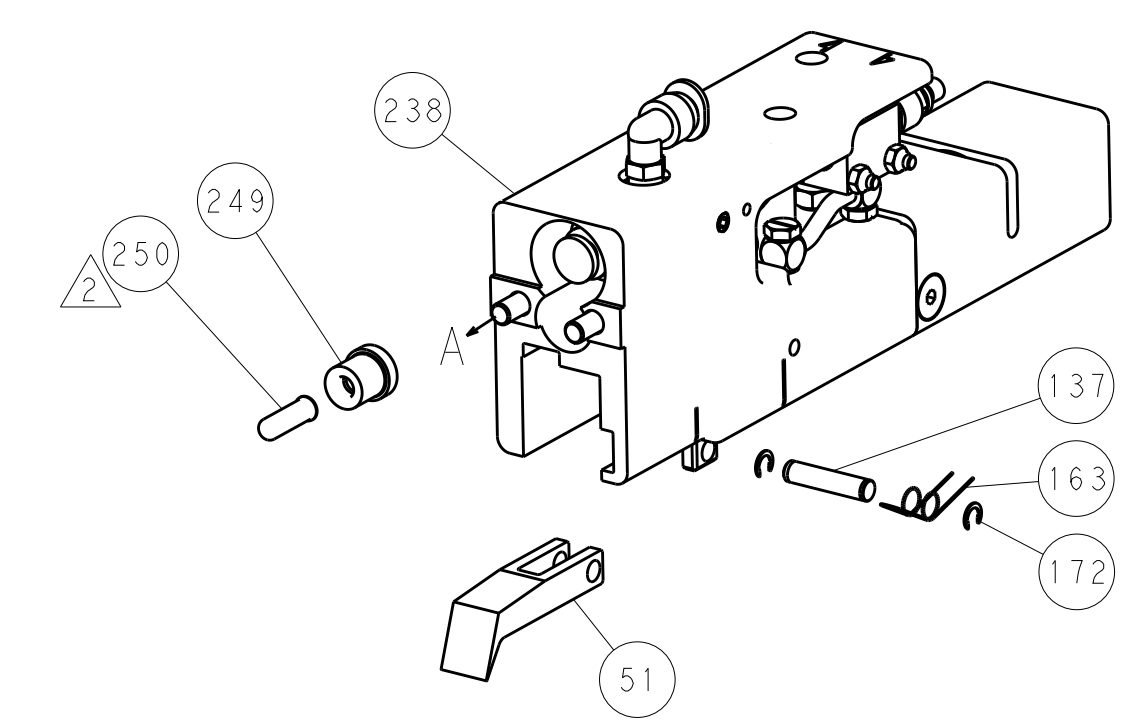

SERVO
LATCH PLATE

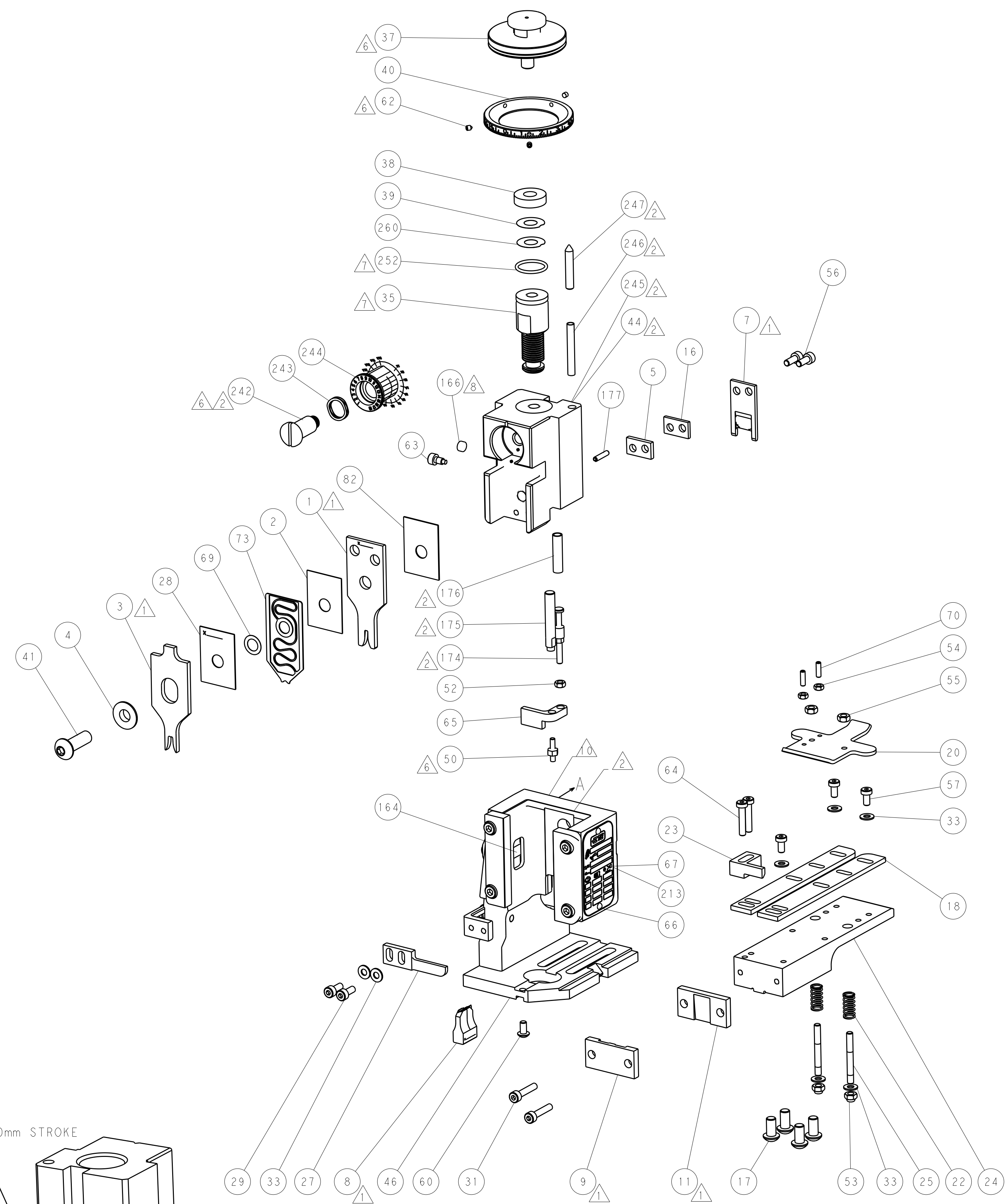
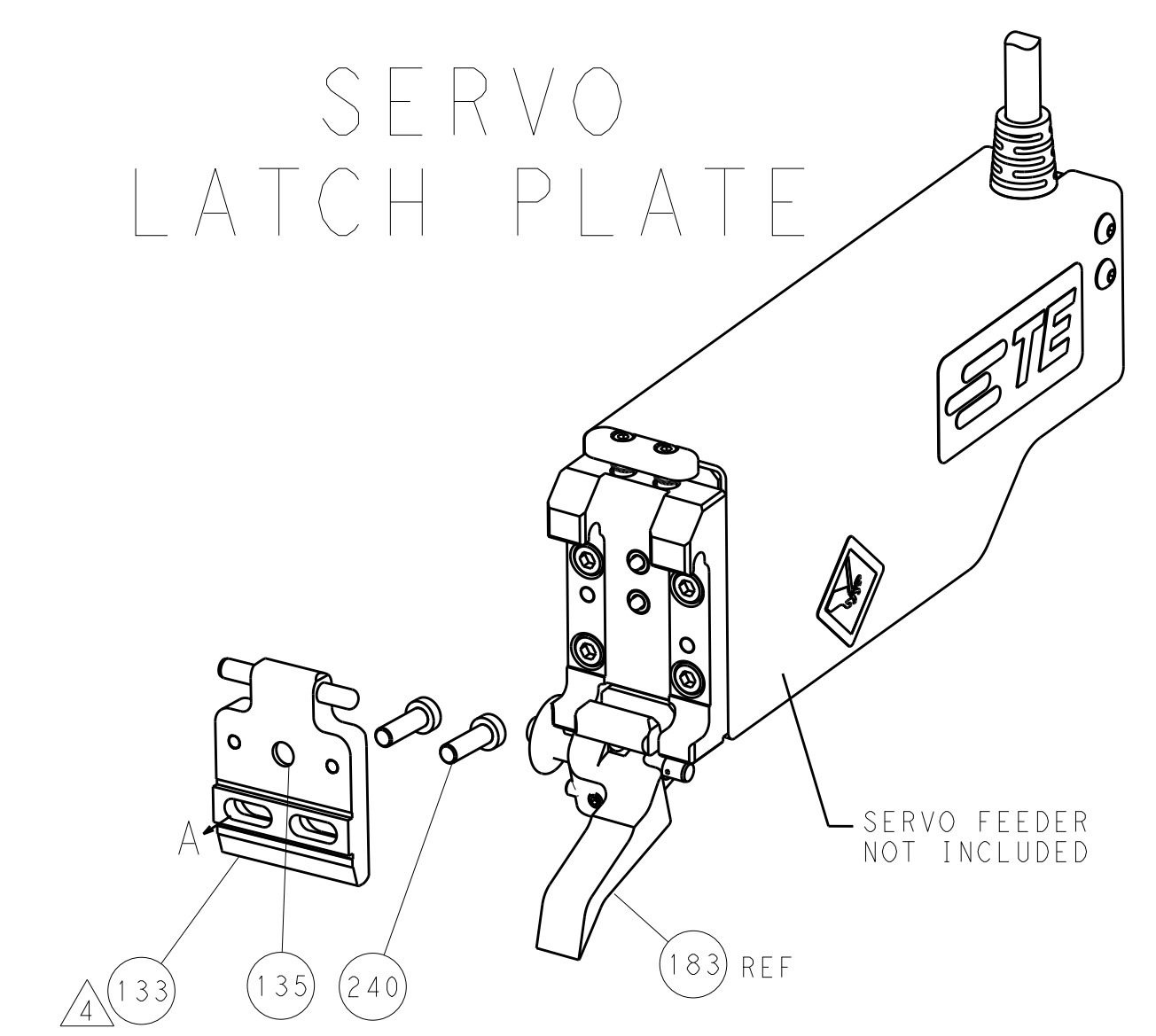

CAM POSITIONS



ATLANTIC VERSION
 Shown on sheets 1 of 4 & 2 of 4
 (Pacific version shown on sheets 3 of 4 & 4 of 4)

DIMENSIONS:		TOLERANCES UNLESS OTHERWISE SPECIFIED:		DWN: Y. YIN 21OCT2013		TE Connectivity	
mm		0 PLC ±0.5		CHK: G. BAILEY 21OCT2013		Harrisburg, PA 17105-3608	
Ø		1 PLC ±0.13		APVD: H. GUO 21OCT2013		NAME: Ocean End Feed Applicator	
H		2 PLC ±0.013		PRODUCT SPEC:		SIZE: CAGE CODE: DRAWING NO:	
A		3 PLC ±0.001		APPLICATION SPEC:		RESTRICTED TO:	
ANGLES		±0.0001		WEIGHT:		A11 00779 ©=2150385	
FINISH:		-		SCALE: 1:1		SHEET 2 OF 4 REV A	
MATERIAL:				Customer Accessible Production Drawing			

PACIFIC VERSION TERMINATOR INTERFACE ADAPTER	PART NUMBER	REVISION	DESCRIPTION	FEED TYPE	APPLICATOR STYLE CONVERSION CHART						
					CONVERT TO	PART NUMBERS REQUIRED					
	2-2150385-1	A	FINE CRIMP HEIGHT ADJUST	MECHANICAL	PNEUMATIC FEED	2119950-1	2119792-2	-	2119641-2	-	2063440-1
					SERVO LATCH PLATE	2119951-1	1901697-1	8-2150385-5	-	-	2168400-7 (QUANTITY 2)
					SMART APPLICATOR	2161326-1	-	8-2150385-4	-	-	-
	2-2150385-2	A	FINE CRIMP HEIGHT ADJUST	PNEUMATIC	MECHANICAL FEED	2119949-1	2063961-1	5-18022-5	2119653-2	-	-
					SERVO LATCH PLATE	2119951-1	1901697-1	8-2150385-5	-	-	2168400-7 (QUANTITY 2)
					SMART APPLICATOR	2161326-1	-	8-2150385-4	-	-	-
	2-2150385-5	A	FINE CRIMP HEIGHT ADJUST	SERVO LATCH PLATE	MECHANICAL FEED	2119949-1	2063961-1	5-18022-5	2119653-2	-	-
					PNEUMATIC FEED	2119950-1	2119792-2	-	2119641-2	-	2063440-1
	2-2150385-7	A	FINE CRIMP HEIGHT ADJUST	NONE	-	-	-	-	-	-	-
	7-2150385-7	A	CRIMP TOOLING KIT	-	-	-	-	-	-	-	-

APPLICATOR DATA		
CRIMP SIZE	TYPE	
WIRE 2.03 mm (.080)	F	
INSUL 3.56 mm (.140)	F	
APPL INSTRUCTIONS 408-10390		

TERMINAL DATA: TE TERMINAL		TE CRIMP SPECIFICATION
TERMINAL NAME: RECEPTACLE, SHUR PLUG		
WIRE STRIP LENGTH 3.66-4.26 mm (.144-.168 IN)		INSULATION DIAMETER RANGE Ø2.16-3.18 mm (.085-.125 IN)
TERMINAL APPLICATION SPECIFICATION 114-2042		
TERMINALS APPLIED		
TE TERMINAL	TE TERMINAL	TE TERMINAL
42581-2		

WIRE SIZE	CRIMP HEIGHT mm [INCH]	CRIMP HEIGHT REFERENCE SETTING
18 AWG	1.52 +/- 0.05 [.060 +/- .002]	7.0
20 AWG	1.40 +/- 0.05 [.055 +/- .002]	8.2
22 AWG	1.35 +/- 0.05 [.053 +/- .002]	8.7

- RECOMMENDED SPARE PARTS
- GREASE BEARING SURFACES LIGHTLY
- LUBRICATE DAILY PER THE APPLICATOR INSTRUCTION SHEET SUPPLIED WITH THE APPLICATOR.
- APPLICATOR SPECIFIC DATA TO BE ENTERED INTO BLANK MEMORY CHIP AT ASSEMBLY. SEE BELOW FOR PART NUMBER:
 MECHANICAL FEED WITH "SMART APPLICATOR" CONVERSION: 8-2150385-4
 PNEUMATIC FEED WITH "SMART APPLICATOR" CONVERSION: 8-2150385-4
 SERVO FEED WITH "FINE CRIMP HEIGHT ADJUST": 8-2150385-5
- ADJUSTMENT OF THE STRIPPER MAY BE REQUIRED WHEN MOVING THE APPLICATOR BETWEEN BENCH AND LEADMAKER APPLICATIONS.
- APPLY PART NUMBER 1-23419-5 LOCTITE TO THREADS OF ITEMS 50, 62 & 242.
- GREASE THREADS, GROOVE AND O-RING ON ITEMS 139 & 153.
- MAGNET, ITEM 166 MUST BE ORIENTED CORRECTLY IN ORDER TO PROPERLY ACTUATE THE COUNTER.
- CRIMP HEIGHT REFERENCE SETTING WAS THE SETTING USED WHEN THE APPLICATOR WAS QUALIFIED AT THE FACTORY. ADJUSTMENT MAY BE NECESSARY WHEN RUNNING APPLICATOR IN THE FIELD.
- SPARE FEED CAM STORAGE LOCATION REFER TO INSTRUCTION SHEET FOR ADDITIONAL INFORMATION.
- THE RECOMMENDED SET-UP FOR END FEED APPLICATORS IS POST-FEED WITH ITEM 2119653-1. THE APPLICATOR CAN BE CONFIGURED FOR PRE-FEED WITH ITEM 2119652-1 BUT MAY ENCOUNTER PROBLEMS WITH SOME APPLICATIONS. FEED ISSUES OR TERMINAL JAMMING MAY OCCUR IN THE PRE-FEED CONFIGURATION.

***WARNING**
 ON INSTALLATION, SET WIRE DISC, ITEM 40 TO LARGEST WIRE SIZE SETTING. USE OF SETTINGS BELOW MINIMUM REQUIRED CRIMP HEIGHT SETTING WILL CAUSE DAMAGE TO CRIMP TOOLING.

ITEM NO	DESCRIPTION	ITEM NO
- 1 1 1 1	2119782-1 FINE ADJUST HEAD ASM, PACIFIC STYLE	251
- - - 1 -	2119640-1 PUSH ROD, AIR FEED	250
- - - 1 -	2079988-1 BUSHING, LCH5-12, MISUMI	249
- 1 1 1 1	1-22279-3 SPRING, COMPRESSION	246
- 1 1 1 1	2119082-7 CAM, SNAIL, INSULATION ADJUSTMENT	244
- 1 1 1 1	2079764-1 WASHER, WAVE SPRING, CREST-TO-CREST	243
- 1 1 1 1	2119083-1 RETAINER, INSULATION DIAL	242
- - 2 - -	2168400-7 SHCS, LOW HEAD, RoHS, M5 X 10	240
- - - - 1	2119580-1 MECHANICAL FEED ASSEMBLY	239
-77-27-25-22-21	PART NO	DESCRIPTION

PACIFIC VERSION
 Shown on sheets 3 of 4 & 4 of 4
 (Atlantic version shown on sheets 1 of 4 & 2 of 4)

SET UP GAUGE	LOC	DIST	REVISIONS			
2119599-2	A	66	REV	DATE	BY	APPV
			-	SEE SHEET 1	-	-

ITEM NO	DESCRIPTION	ITEM NO
- - - 1 -	2063440-1 AIR FEED MODULE	238
- - 1 - -	2119740-2 TAG, IDENTIFICATION	213
- 4 4 4 4	2079383-9 SCR, BHSC, RoHS (M6 X 20)	186
- - REF - -	1901697-1 FEED FINGER ASSEMBLY, EF	183
- 1 1 1 1	6-993111-6 PIN, SLOTTED SPRING 3.0 X 14.0	177
- 1 1 1 1	8-22280-7 SPRING, COMPRESSION	176
- 1 1 1 1	1752353-2 GUIDE PIN, HOLDDOWN	175
- 1 1 1 1	1901680-2 GUIDE PIN, HOLDDOWN	174
- - - 2 -	21045-3 RING, RETAIN, EXTERN, 3/16 CRESCENT	172
- 1 1 1 1	994969-1 MAGNET, RARE EARTH HIGH ENERGY	166
- REF REF REF REF	994970-2 COUNTER, MAGNETIC	164
- - - 1 -	240638-1 SPRING, FEED FINGER	163
- 1 1 1 1	8-21084-1 O-RING, .801 ID, .070 DIA. MAT.	153
- - - 1 -	2119641-2 FEED CAM, AIR FEED	152
- 1 1 1 1	2119798-2 DETENT PIN	145
- 1 1 1 1	2079383-8 SCR, BHSC, RoHS (M4 X 16)	144
- - - 1 -	2119653-2 FEED CAM, POST FEED	142
- 1 1 1 1	2119655-6 APPLICATOR BASIC ASSEMBLY, EF	141
- 1 1 1 1	2119651-1 RAM, ASIAN STYLE, END FEED	140
- 1 1 1 1	2119092-2 BOLT, ADJUSTMENT	139
- - - 1 -	3-23627-7 PIN, RETAIN, GRVD, 3/16 X .854	137
- - REF - -	SEE NOTE 4 MEMORY CHIP, PROGRAMMED	135
- - 1 - -	1633743-1 SERVO FEED LATCH ASM	133
- 1 1 1 1	455888-5 SPACER, CRIMPER	82
- 1 1 1 1	2119791-9 DEPRESSOR, WIRE	73
- 1 1 1 1	2119956-2 DOCUMENTATION PACKAGE	71
- 2 2 2 2	2-18032-2 SCR, SET, FLT POINT M3 X 10.0	70
- 1 1 1 1	2119943-1 WASHER, SPACER	69
- 1 - 1 1	2119740-1 TAG, IDENTIFICATION	67
- 2 2 2 2	2168078-1 SCREW, DRIVE, RH, RoHS, 2 x .188	66
- 1 1 1 1	1901681-1 HOLDDOWN, TERMINAL	65
- 2 2 2 2	2168400-5 SHCS, LOW HEAD, RoHS, M4 X 20	64
- 1 1 1 1	2119793-1 LIMITER, ADJUSTMENT BOLT	63
- 3 3 3 3	992763-5 SCR, SET, SOC, CONE POINT, M3 X 4.0	62
- - - - 1	5-18022-5 SCR, HEX HD CAP, M4 X 6.0	59
- - - - 1	2063961-1 FEED FINGER	58
- 3 3 3 3	2168400-4 SHCS, LOW HEAD, RoHS, M4 X 8	57
- 2 2 2 2	1-2168083-0 SCR, SKT HD CAP, RoHS, M4 X 10	56
- 2 2 2 2	5018030-2 NUT, HEX, REG, RoHS, M4	55
- 2 2 2 2	5018030-1 NUT, HEX, REG, RoHS, M3	54
- 2 2 2 2	986965-8 NUT, LOCK, HEX, TORQUE (M4)	53
- 1 1 1 1	1-5018030-0 NUT, HEX, REG, RoHS, M3.5	52
- - - 1 -	2119792-2 PAWL, EF, AIR	51
- 1 1 1 1	1-1976055-6 STANDOFF, HOLD-DOWN	50
- - - 1 2	18023-9 SCR, SKT HD CAP M4 X 6.0	49
- - - - 1	2119652-1 FEED CAM, PRE FEED	48
- 1 1 1 1	2079383-7 SCR, BHSC, RoHS (M8 X 25)	41
- 1 1 1 1	2119645-1 DISC, NUMBERED FA WIRE ADJUSTMENT	40
- 1 1 1 1	2119957-1 APPLICATOR SHIM PACK	39
- 1 1 1 1	1-2119644-2 RAM WASHER, PRECISION	38
- 7 7 7 7	1-18028-2 WASHER, FLAT, REG M4	33
- 2 2 2 2	2168083-9 SCR, SKT HD CAP, RoHS, M4 X 20	31
- 2 2 2 2	1-2168083-0 SCR, SKT HD CAP, RoHS, M4 X 10	29
- 1 1 1 1	455888-4 SPACER, CRIMPER	28
- 1 1 1 1	240639-1 STRIPPER (MACHINING)	27
- 2 2 2 2	1320906-1 STUD, THREADED	25
- 1 1 1 1	1752371-1 PLATE, STRIP GUIDE	24
- 1 1 1 1	240825-1 PLATE, STRIP HOLD DOWN	23
- 2 2 2 2	2-22281-3 SPRING, COMPRESSION	22
- 1 1 1 1	1752373-4 DRAG	20
- 2 2 2 2	1901259-6 GUIDE, LOWER STRIP	18
- 1 1 1 1	3-240641-7 SPACER	16
- 1 1 1 1	240644-1 PLATE, REAR SHEAR	11
- - - - -	-	10
- 1 1 1 1	690482-4 PLATE, FRONT SHEAR	9
1 1 1 1 1	1333216-5 ANVIL, COMBINATION	8
- 1 1 1 1	1-2217206-0 BLADE, SLUG	7
- - - - -	-	6
- 1 1 1 1	240641-7 SPACER	5
- 1 1 1 1	238009-1 BLOCK, FL CRIMPER SPACER	4
1 1 1 1 1	2-1633961-3 CRIMPER, INSULATION F PREMIUM	3
- 1 1 1 1	455888-3 SPACER, CRIMPER	2
1 1 1 1 1	1-456405-5 CRIMPER, WIRE PREMIUM	1
-77-27-25-22-21	PART NO	DESCRIPTION

DIMENSIONS:	TOLERANCES UNLESS OTHERWISE SPECIFIED:	DATE	BY	APPV
mm	0 PLC ±.5 1 PLC ±0.5 2 PLC ±0.13 3 PLC ±0.013 4 PLC ±0.0001	21OCT2013	Y. YIN	21OCT2013
	ANGLES ±.0001	21OCT2013	G. BAILEY	
MATERIAL:	FINISH:	NAME	TE Connectivity Harrisburg, PA 17105-3608	
		PRODUCT SPEC	Ocean End Feed Applicator	
		APPLICATION SPEC	SIZE: A1 CAGE CODE: 00779 DRAWING NO: C=2150385	
		WEIGHT:	Customer Accessible Production Drawing SCALE: 1:1 SHEET 3 OF 4 REV A	

LOC		DIST		REVISIONS			
A	66	P	LTM	DESCRIPTION	DATE	OWN	APVD
		-		SEE SHEET 1			

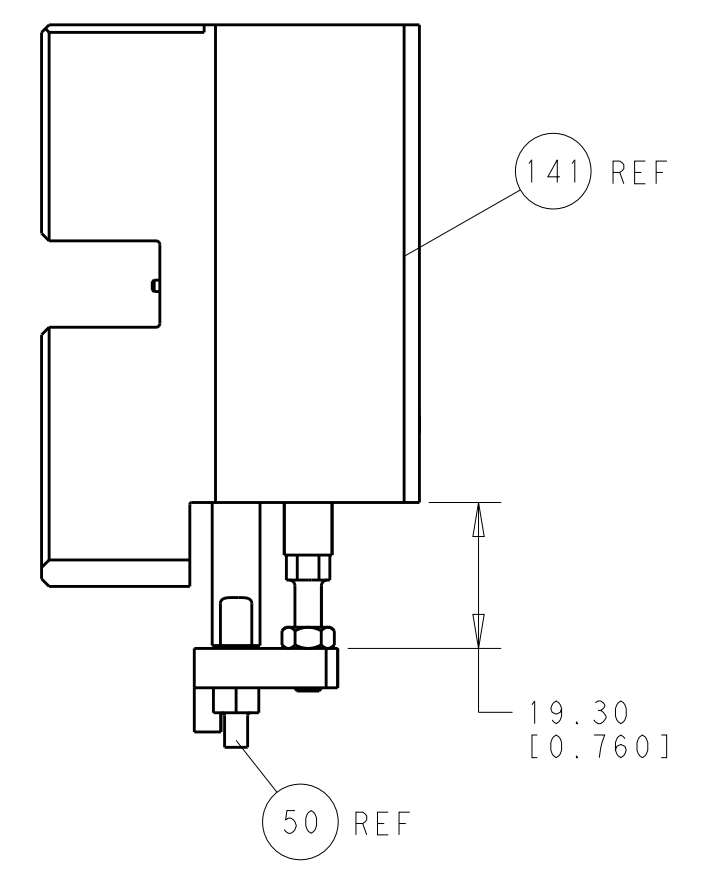

HOLDDOWN SET-UP

FEED TYPE
MECHANICAL

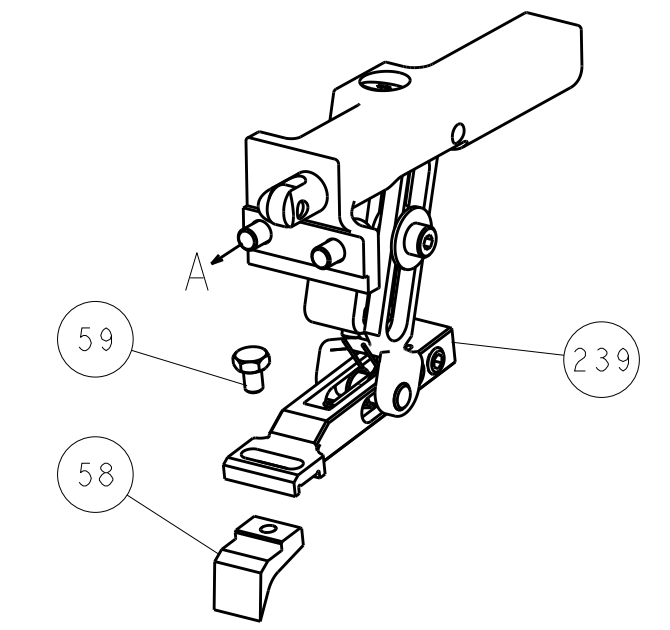

PNEUMATIC

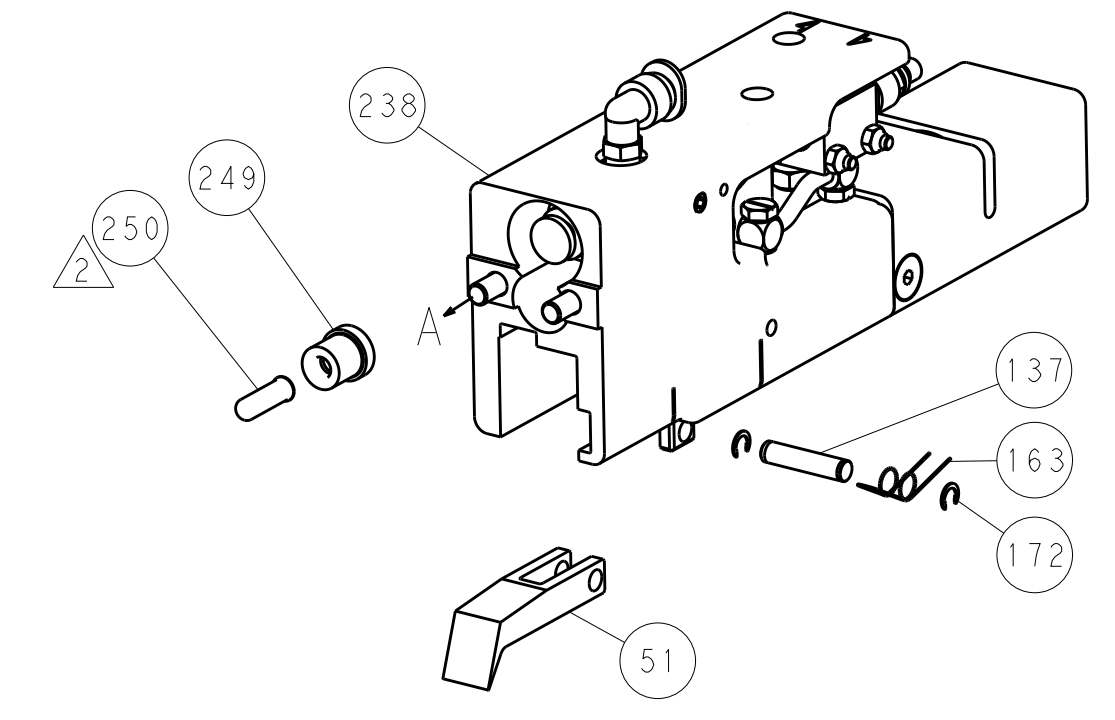

SERVO
LATCH PLATE

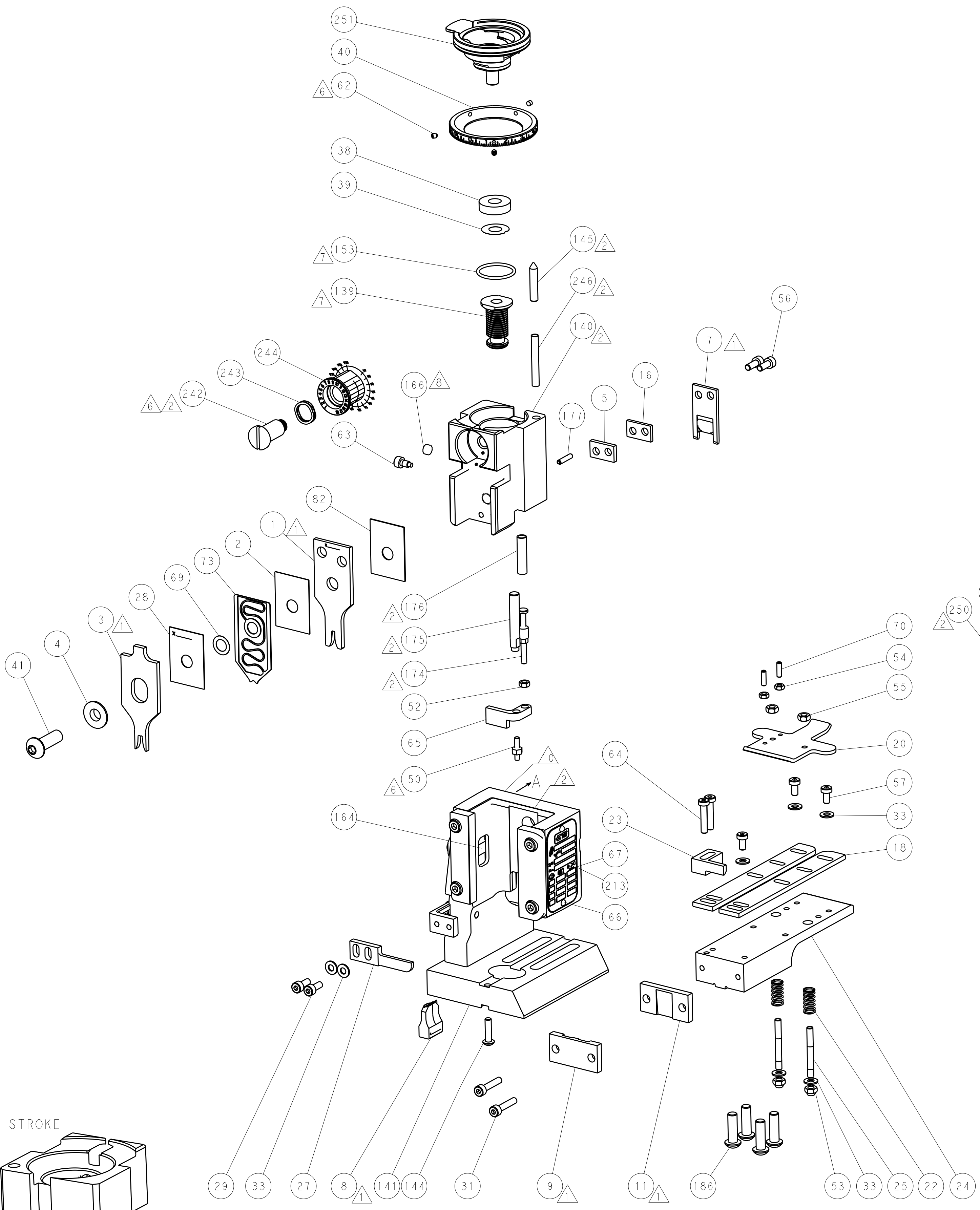
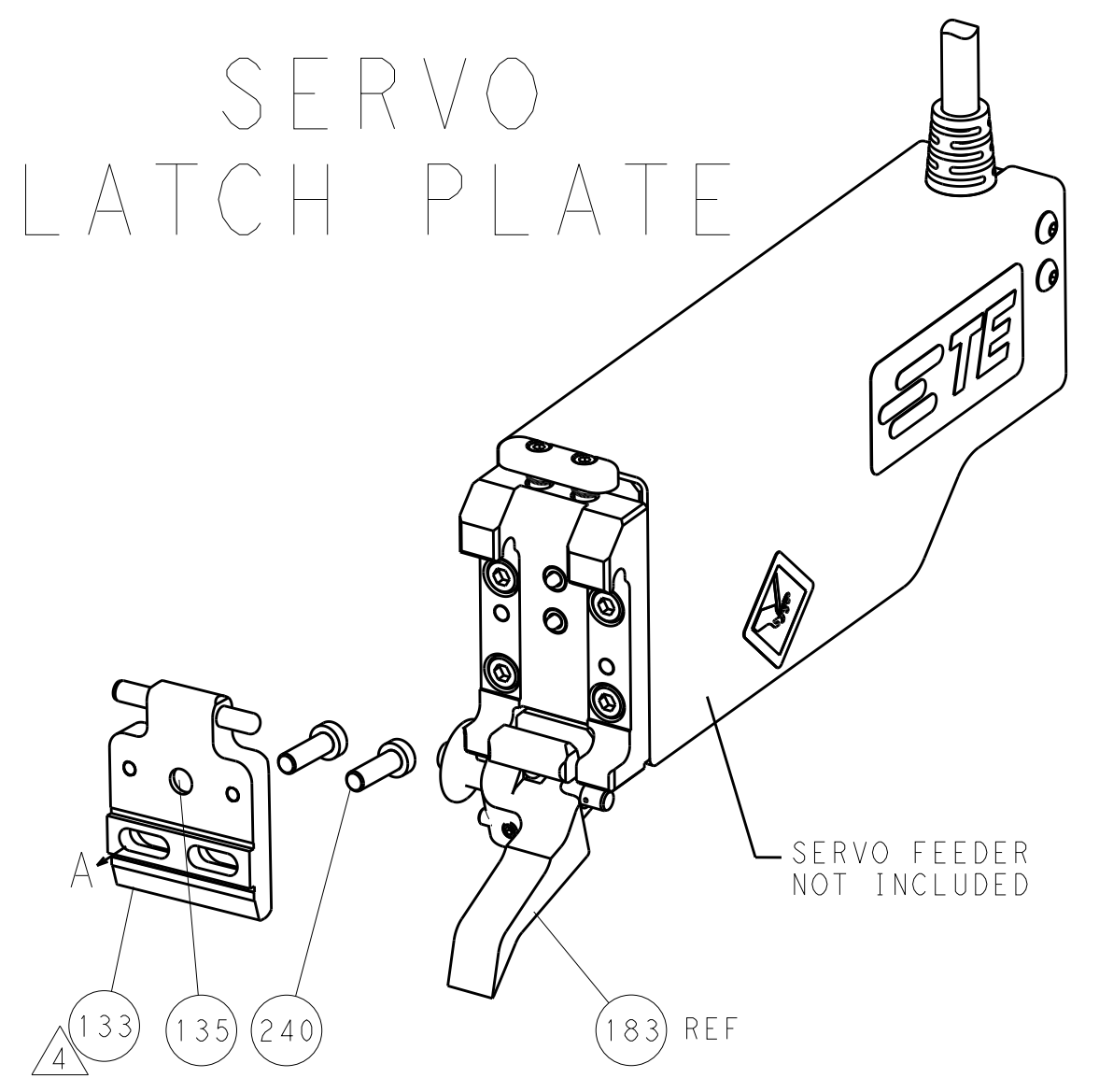

CAM POSITIONS

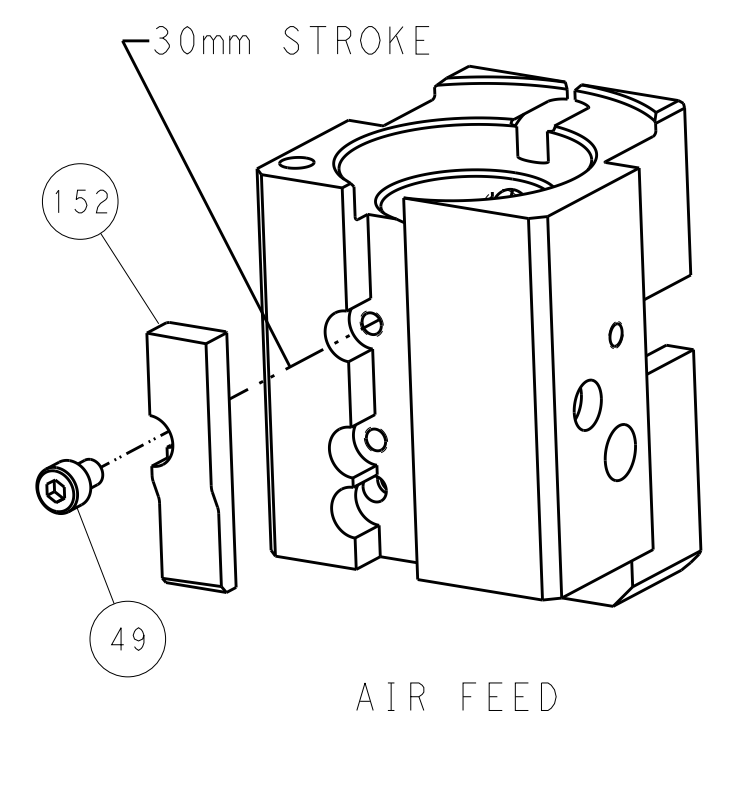
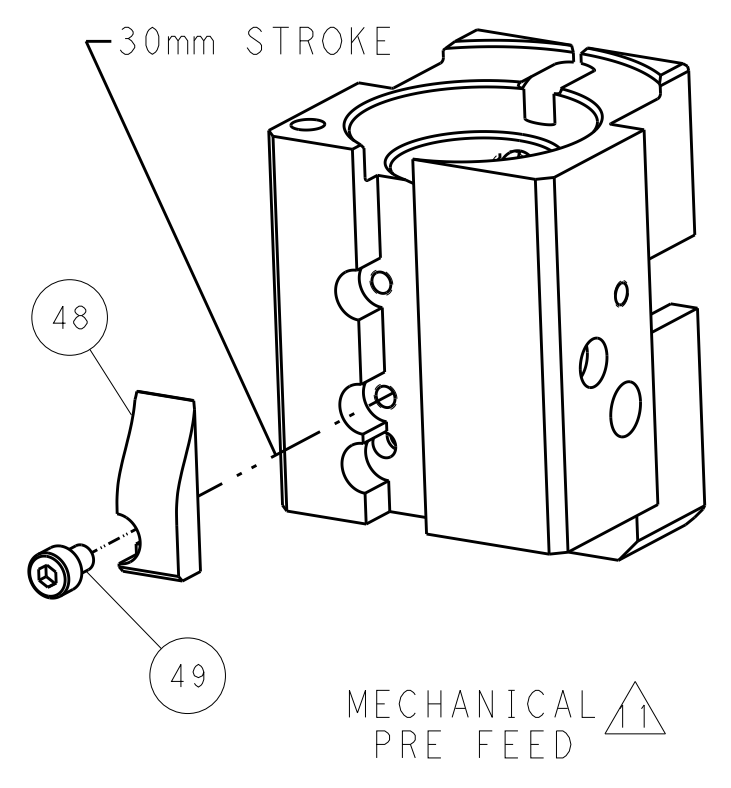
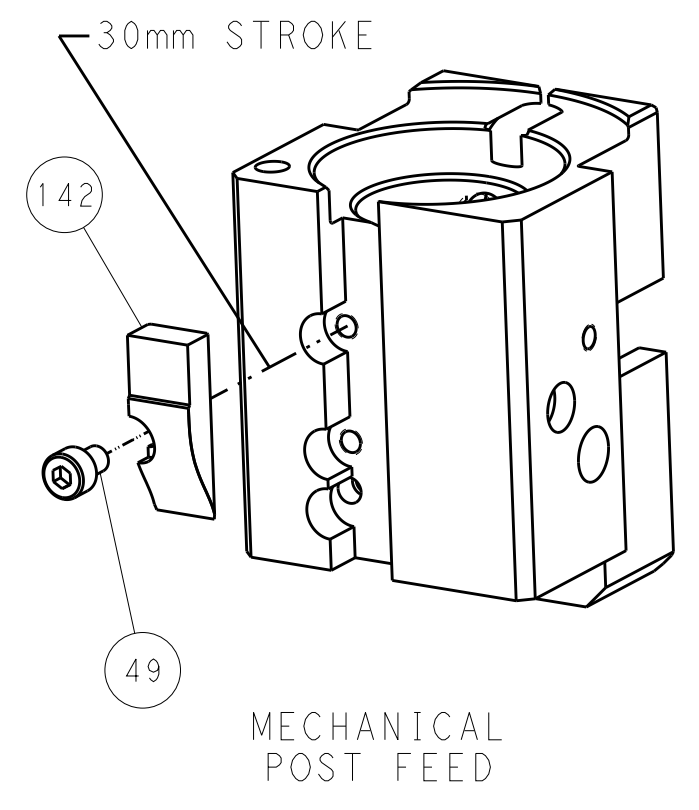

PACIFIC VERSION
Shown on sheets 3 of 4 & 4 of 4
(Atlantic version shown on sheets 1 of 4 & 2 of 4)

DIMENSIONS:		TOLERANCES UNLESS OTHERWISE SPECIFIED:		DWG: Y. YIN 21OCT2013		TE Connectivity	
mm	0 PLC ±0.5	1 PLC ±0.5	2 PLC ±0.13	3 PLC ±0.13	4 PLC ±0.013	5 PLC ±0.0013	Harrisburg, PA 17105-3608
	ANGLES ±0.0013			CHK: G. BAILEY 21OCT2013	NAME: Ocean End Feed Applicator		RESTRICTED TO
MATERIAL:	FINISH:			APVD: JJ. GUO 21OCT2013	SIZE: CAGE CODE: DRAWING NO: A11 00779 C=2150385		SCALE: 1:1 SHEET 4 OF 4 REV A
Customer Accessible Production Drawing				Customer Accessible Production Drawing			