

REVISIONS									
MOD	LOC	DIST	P	F	ZONE	LTR	DESCRIPTION	DATE	APPD
-	GP	00				G	REV PER EC QUE0-0002-01	09 JAN 02	JR

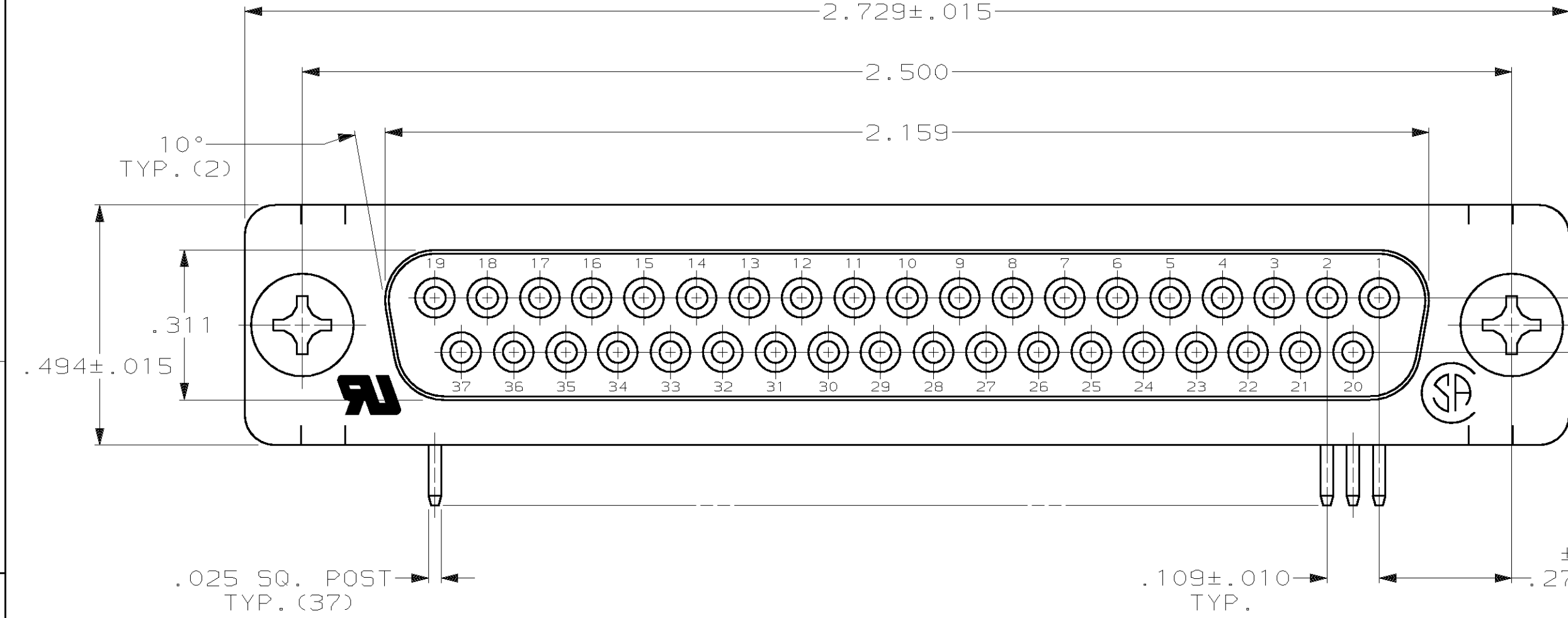

1. CONNECTOR MATES WITH ANY 37 POS. PLUG IN AMPLIMITE SERIES & COMPLIES WITH AMP SPEC. 108-40,005 WHERE APPLICABLE.
2. FLAME RETARDANT 94V-0 RATED THERMOPLASTIC; COLOR: BLACK.
3. STEEL PER ASTM A109.
4. PHOS. BRONZE PER QQ-B-750.
5. TIN PLATING PER MIL-T-10727, GOLD PLATING PER MIL-G-45204, NICKEL PLATING PER QQ-N-290.
6. TIN PLATED.
7. GOLD FLASH FOR A LENGTH OF .100 MINIMUM FROM MATING END, .000100 MINIMUM TIN-LEAD ON OPPOSITE END, BOTH OVER .000050 MINIMUM NICKEL.
8. .000030 MINIMUM GOLD FOR A LENGTH OF .100 MINIMUM FROM MATING END, .000100 MINIMUM TIN-LEAD ON OPPOSITE END, BOTH OVER .000050 MINIMUM NICKEL.
9. SCREWS ARE FOR -1 & -2.

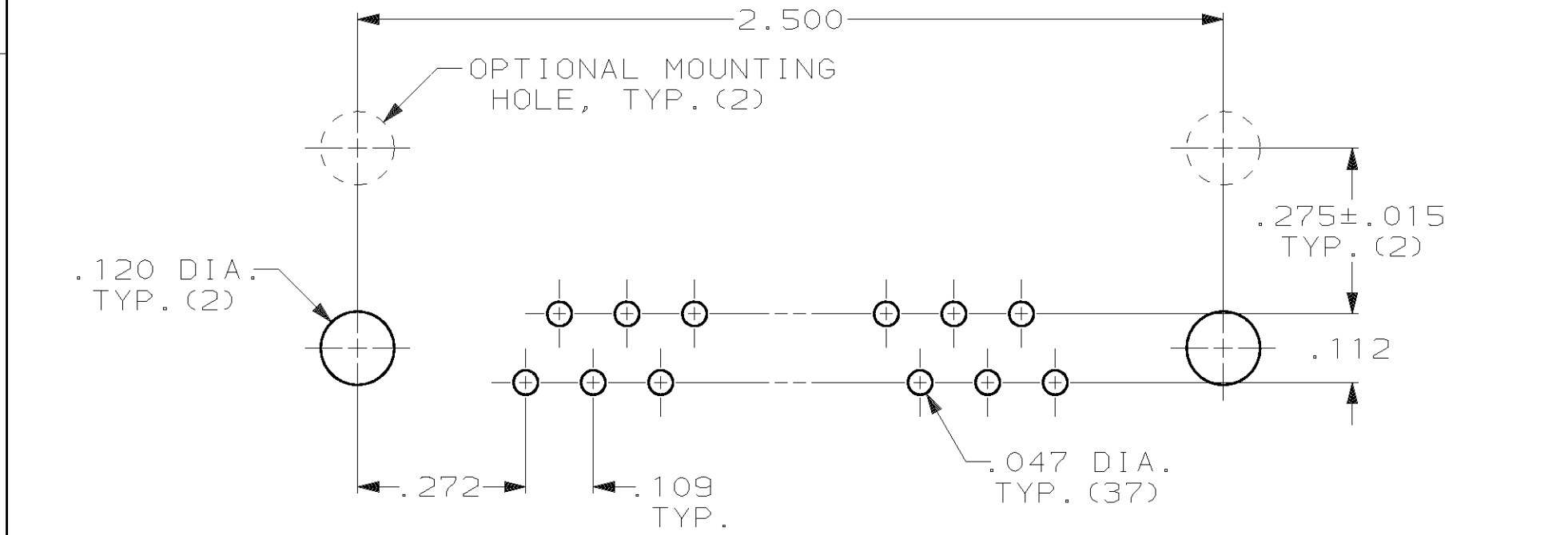
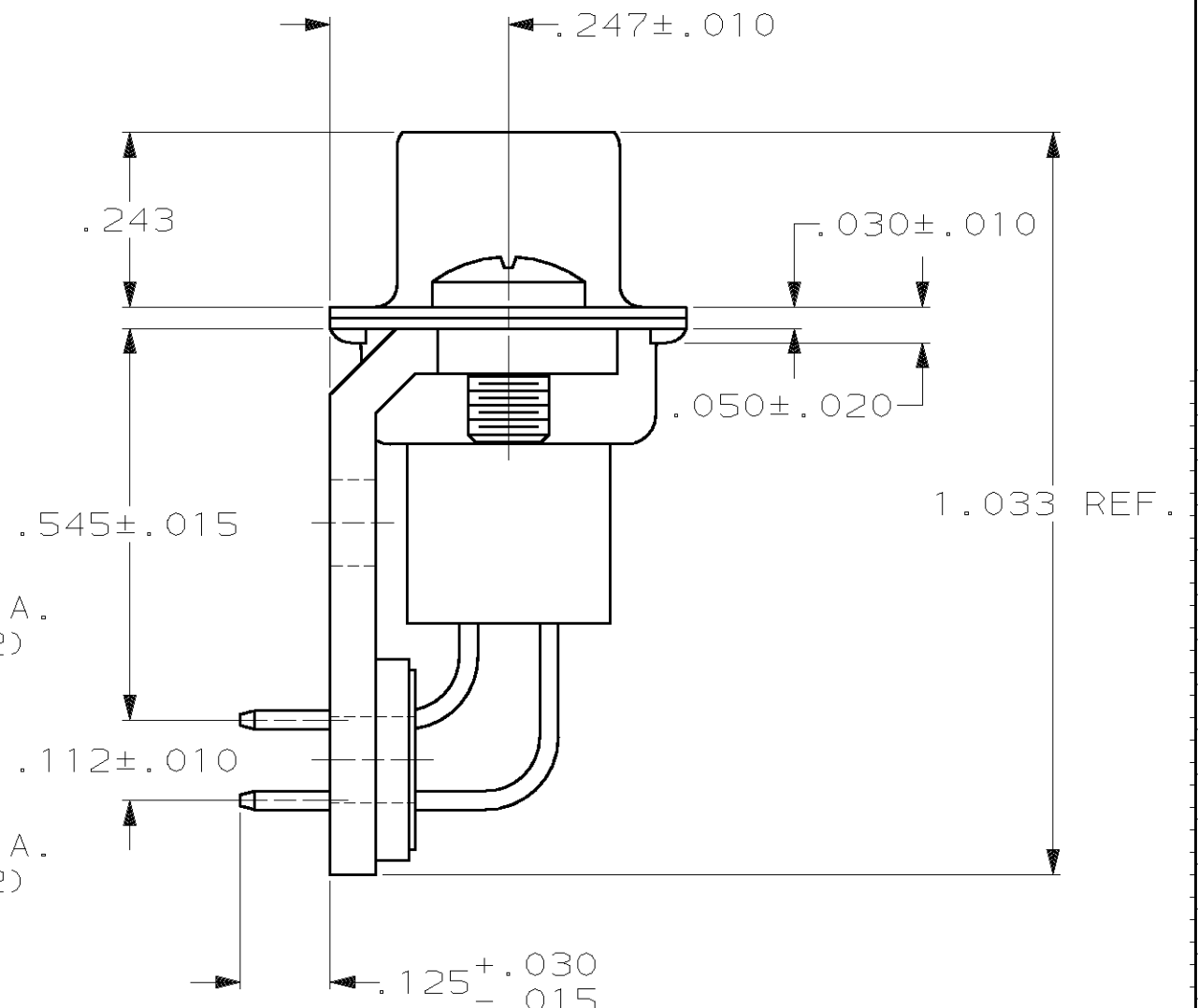
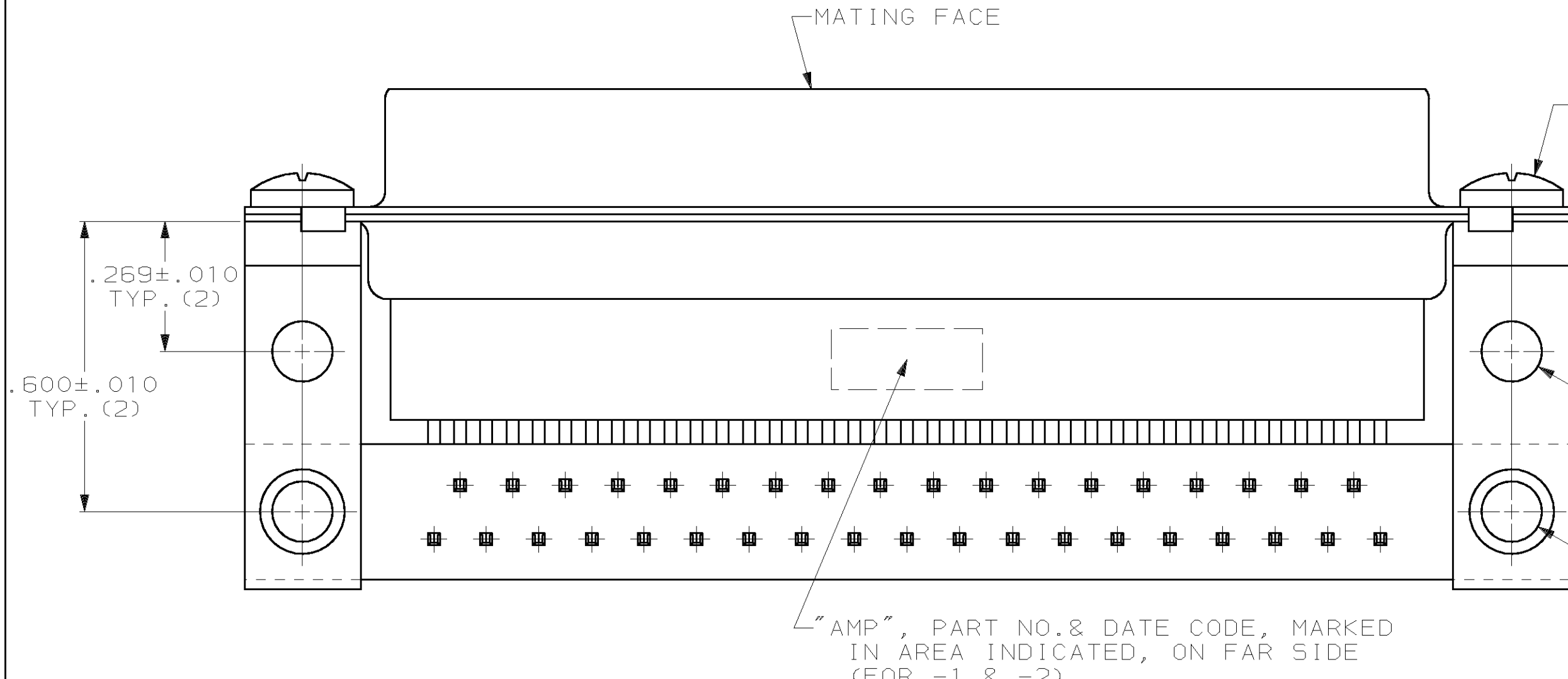

CONTACT FINISH	PART NO
OBSOLETE	745115-3
OBSOLETE	745115-2
OBSOLETE	745115-1

DO NOT SCALE PRINT. UNLESS SPECIFIED DIMENSIONS IN INCHES TOLERANCES ON : 2 PLC DEC ± - 3 PLC DEC ± .005 ANGLES ± 2°	DR 12-15-83 J. GERACE CHK 12-15-83 J. GERACE APPD 3-15-84 P. SWEIGARD APPD 3-15-84 J. ASSINI PRODUCT SPEC - APPLICATION SPEC -	AMP AMP Incorporated Harrisburg, PA 17105-3608 NAME RECEPTACLE ASSEMBLY, SIZE 4, 37 POS., RIGHT ANGLE, .545 SERIES, .025 SQ. POSTS, AMPLIMITE™ HDP	
MATERIAL MOLDED PARTS: 2 SHELLS & BRACKETS: 3 CONTACTS: 4	FINISH SHELLS & BRACKETS: 6 CONTACTS: SEE TABLE	SIZE C	CAGE CODE 00779
THIS DRAWING IS A CONTROLLED DOCUMENT FOR AMP INCORPORATED. IT IS SUBJECT TO CHANGE AND THE CONTROLLING ENGINEERING ORGANIZATION SHOULD BE CONTACTED FOR THE LATEST REVISION.		DRAWING NO C=745115	SCALE NTS
		SHEET 1 OF 1	