

THIS DRAWING IS A CONTROLLED DOCUMENT.

819528-1

D

C

B

A

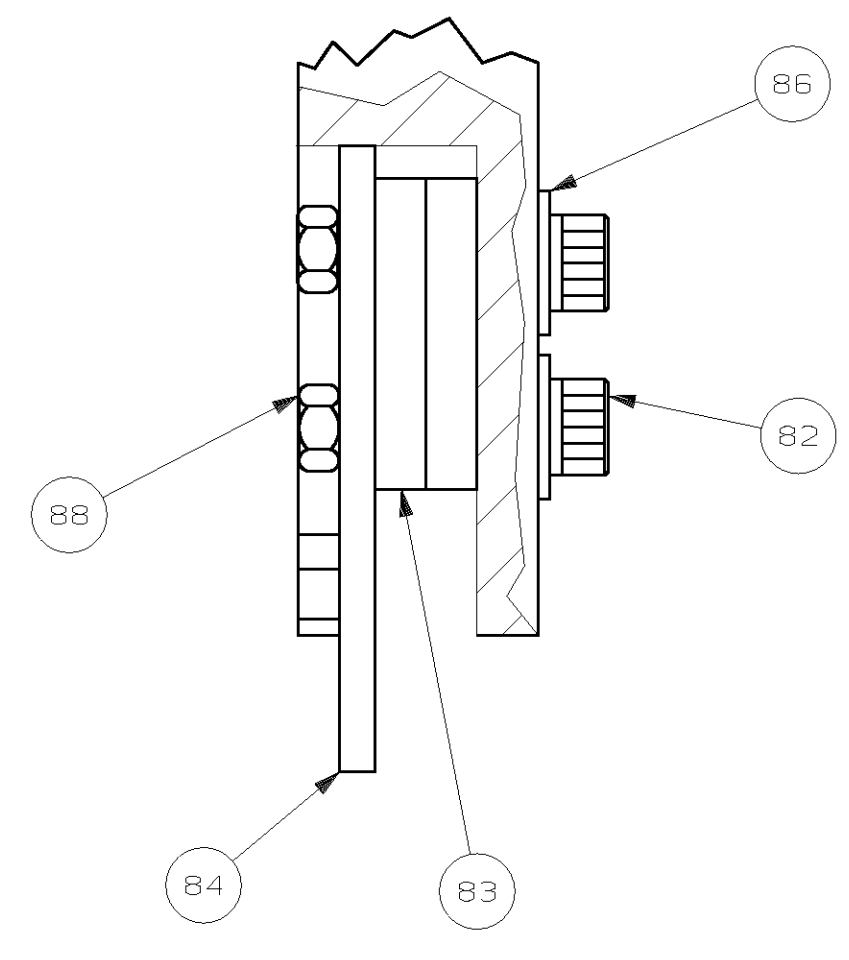

DETAIL K
SCALE 2:1

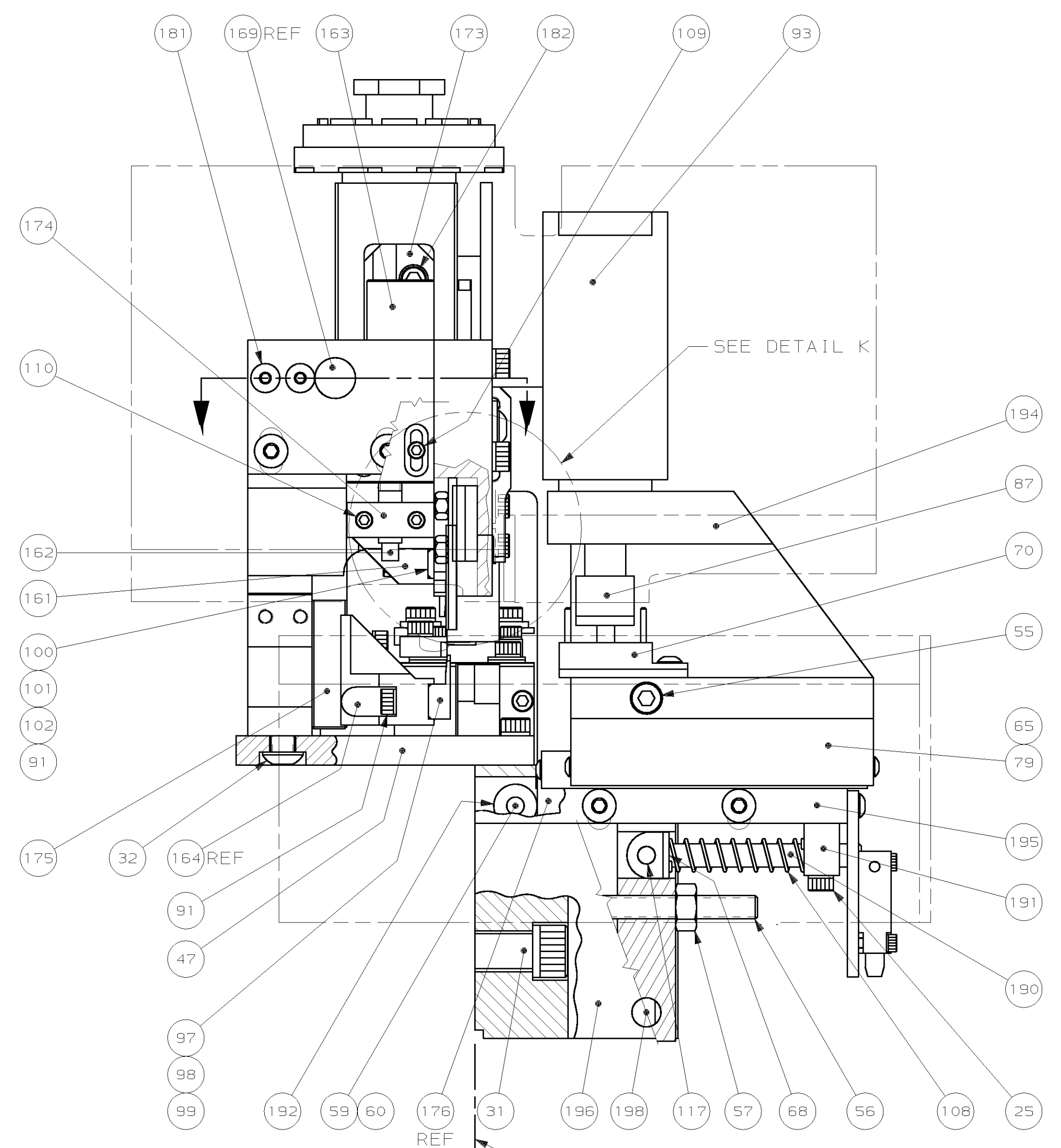
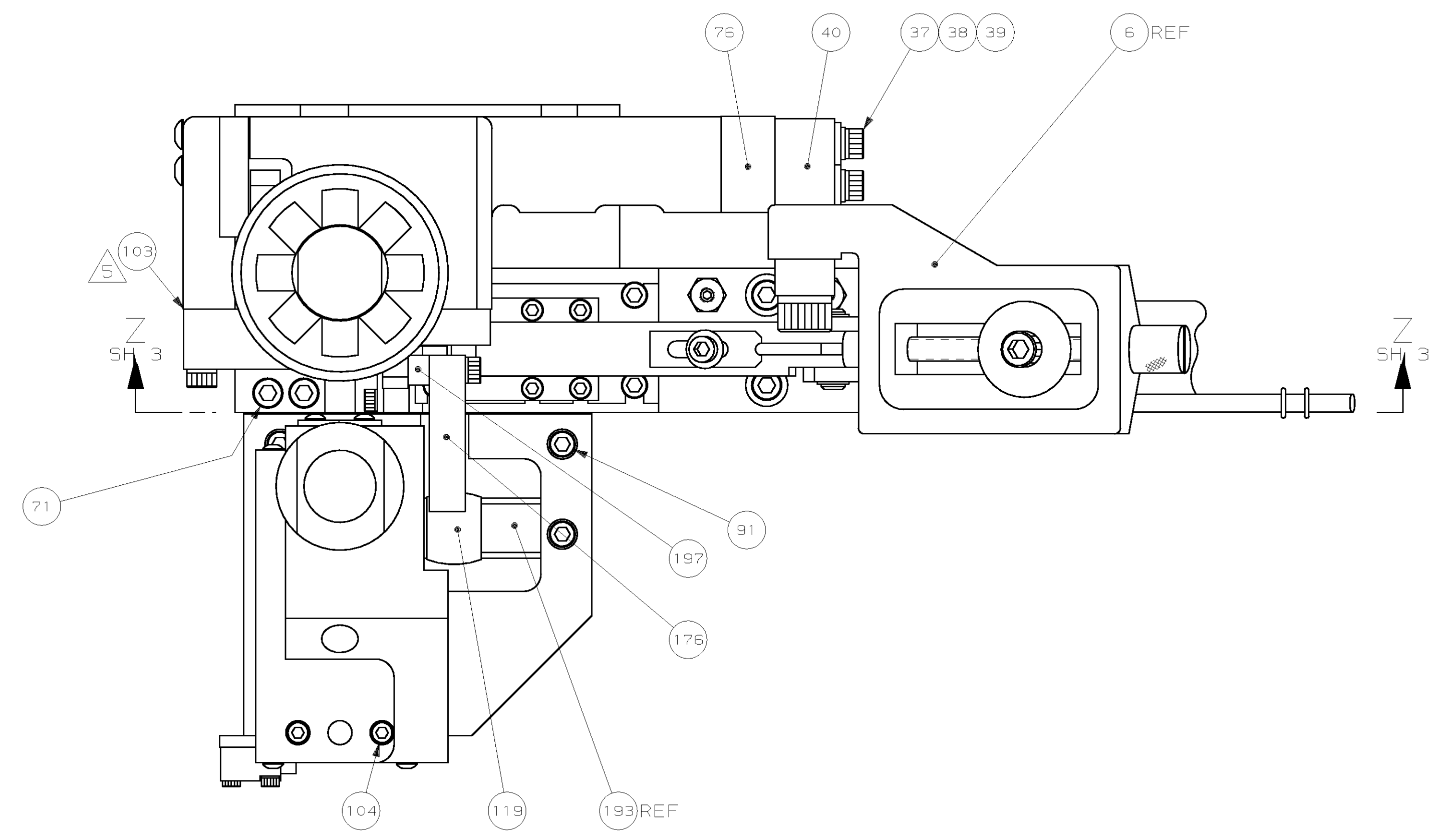
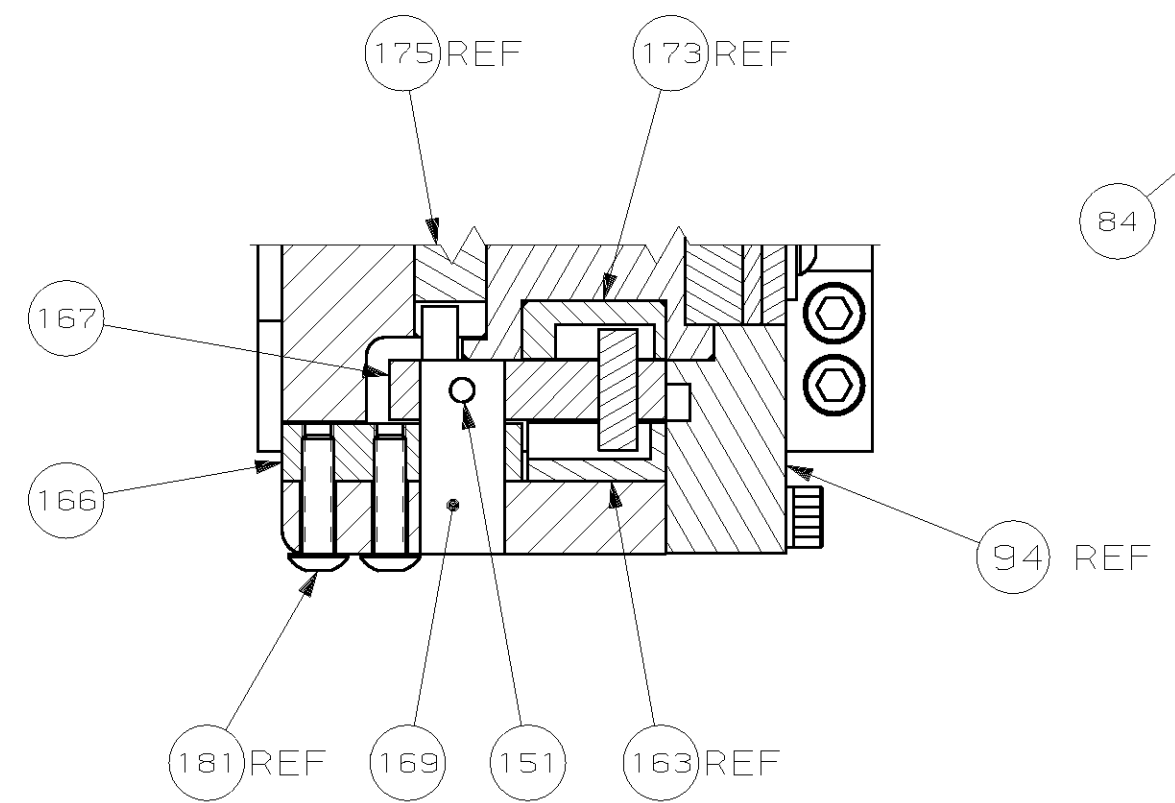

SCRAP HOLE CENTER LINE IN BENCH

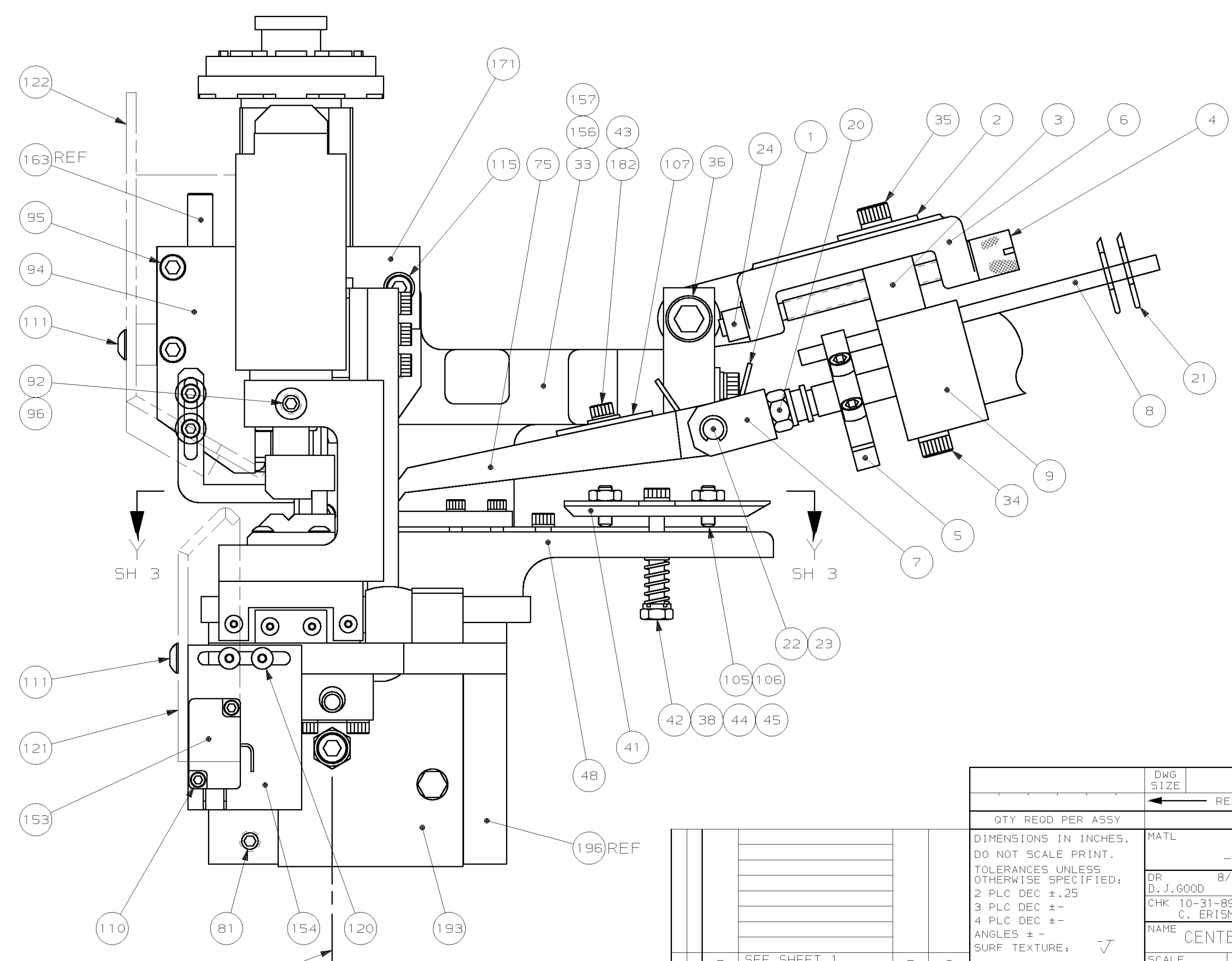

THIS DRAWING IS UNRELEASED FOR PUBLICATION BY AMP INCORPORATED. ALL RIGHTS RESERVED.

LOC A
DIST 66

DWG SIZE		PART NO		DESCRIPTION		ITEM NO
REVISION OF EACH ASSY NO (WHEN BLANK, USE DWG REVISION)						
QTY REQD PER ASSY		PARTS LIST				
DIMENSIONS IN INCHES. DO NOT SCALE PRINT.		MATL	HT TR	FIN		
TOLERANCES UNLESS OTHERWISE SPECIFIED:		DR 8/11/89 APP -		AMP INCORPORATED		
2 PLC DEC ± .25		D.J. GOOD		Harrisburg, Pa. 17105		
3 PLC DEC ± .1		CHK 10-31-89 REL 1-25-90		MACHINE REF CENTER STRIP MACHINE		
4 PLC DEC ± .1		C. ERISMAN B. MCPHERSON				
ANGLES ± -		NAME		CENTER STRIP APPLICATOR ASSEMBLY		
SURF TEXTURE: ✓		SCALE		SHEET REV		
REMOVE BURRS, BREAK SHARP EDGES .015 R MAX		1:1		2 OF 4 M3		
CASE CODE 00779		CUSTOMER AND ASSEMBLY DRAWING 1		RESTRICTED TO		

REV	DATE	APP	DATE
1	8/11/89		
2	10/31/89		
3	1/25/90		

THIS DRAWING IS A CONTROLLED DOCUMENT.

RELEASED FOR PUBLICATION BY AMP INCORPORATED. ALL RIGHTS RESERVED.

THIS DRAWING IS UNRELEASED. COPYRIGHT 19

LOC A
DIST 66

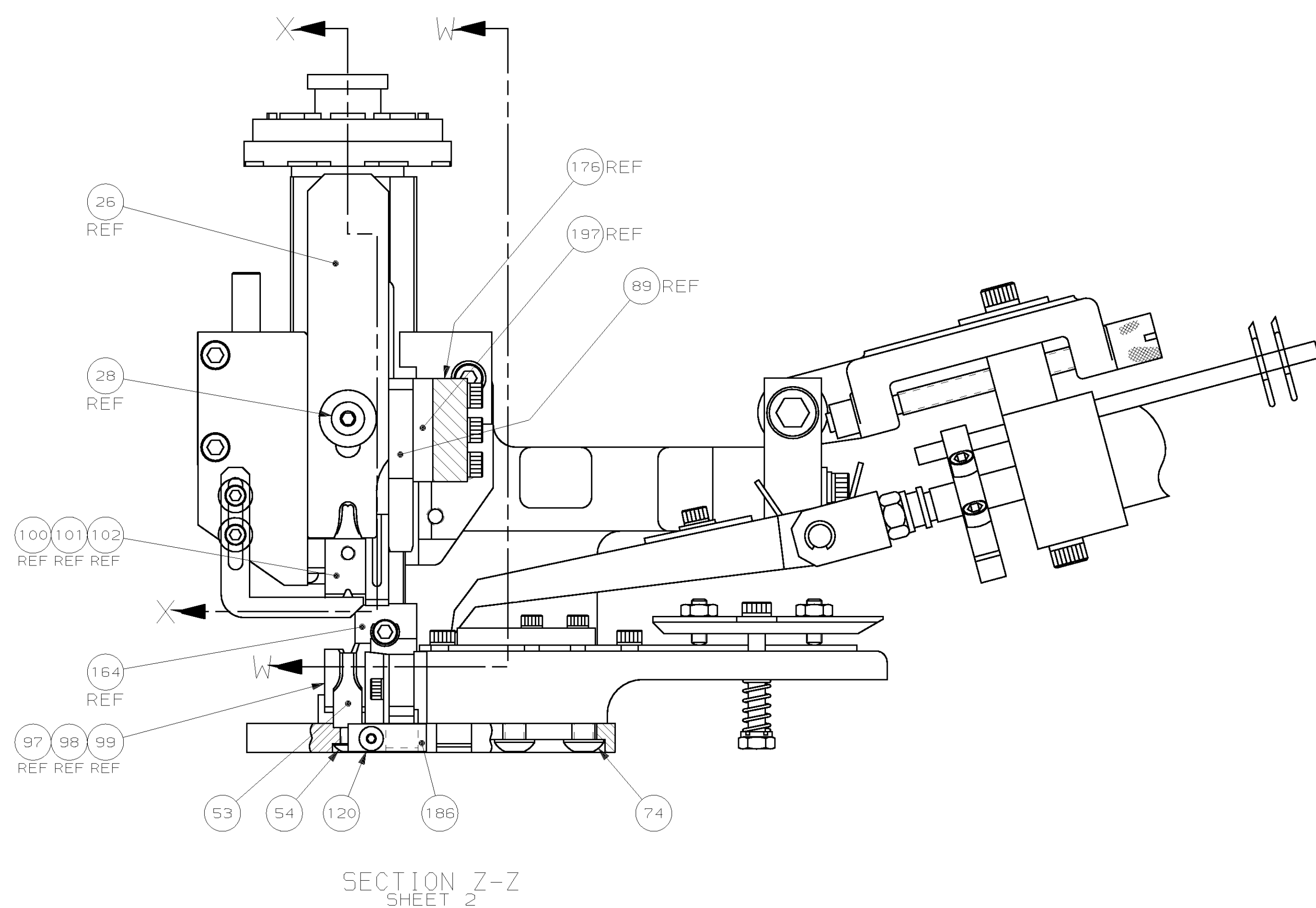
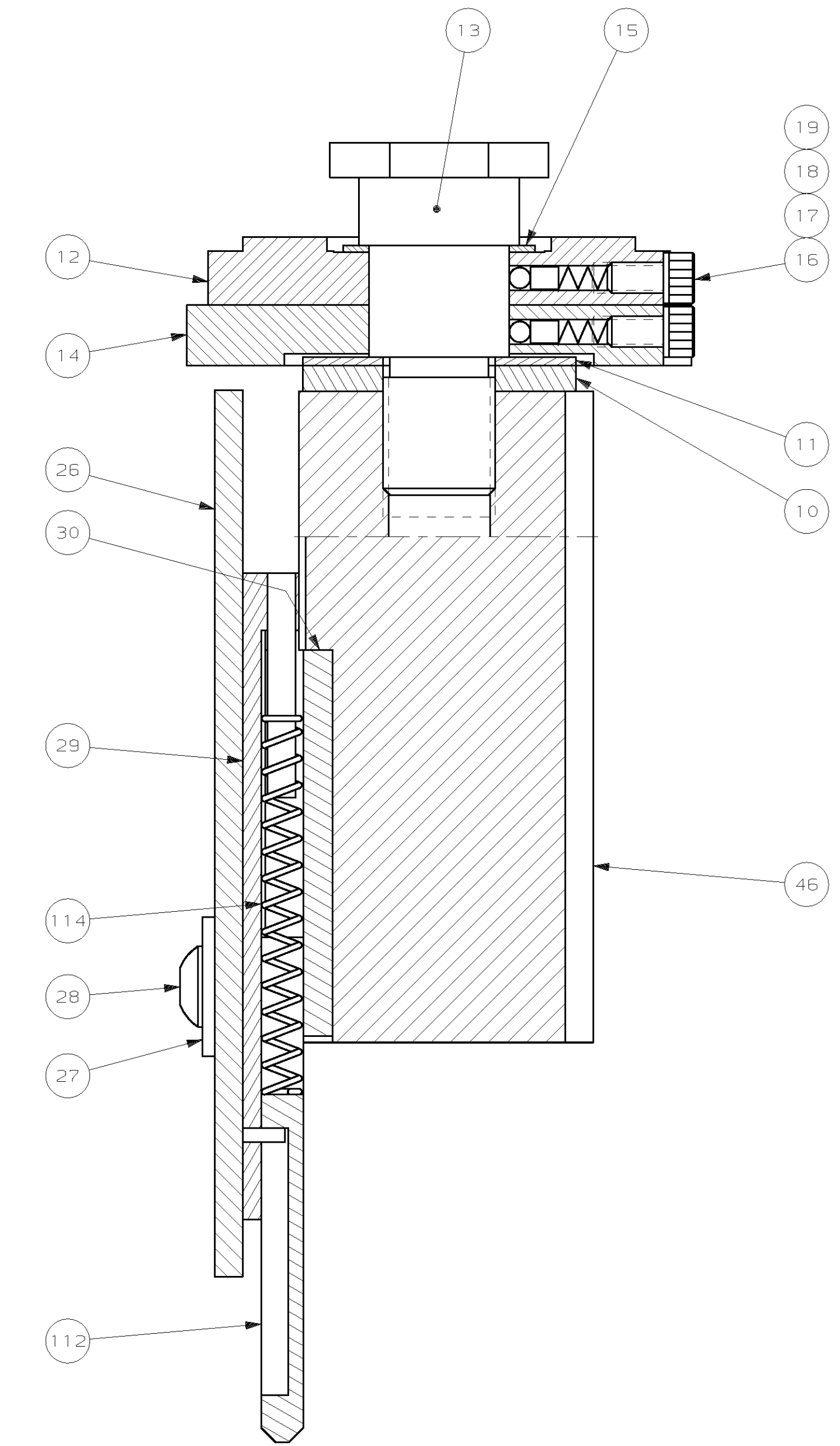
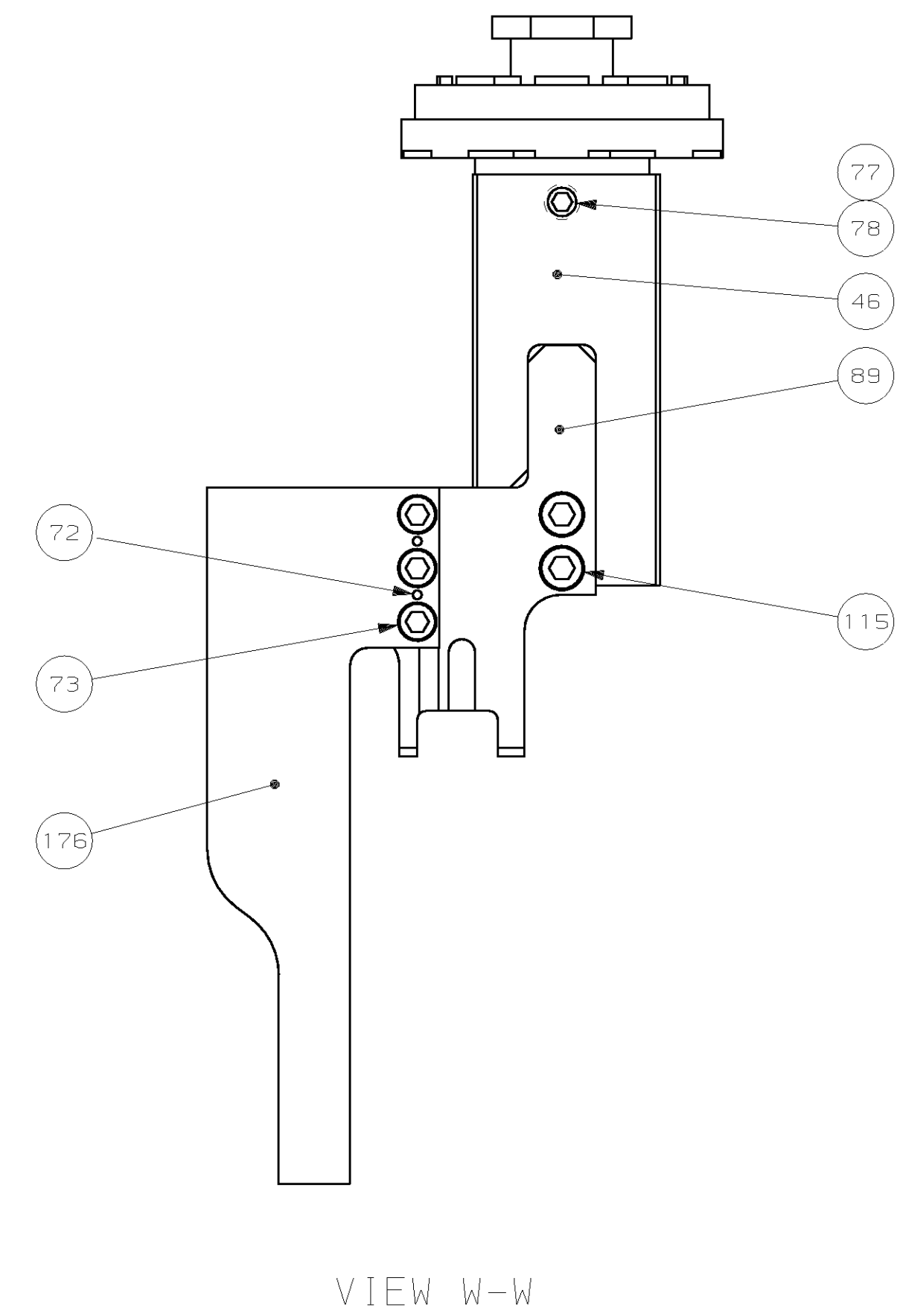
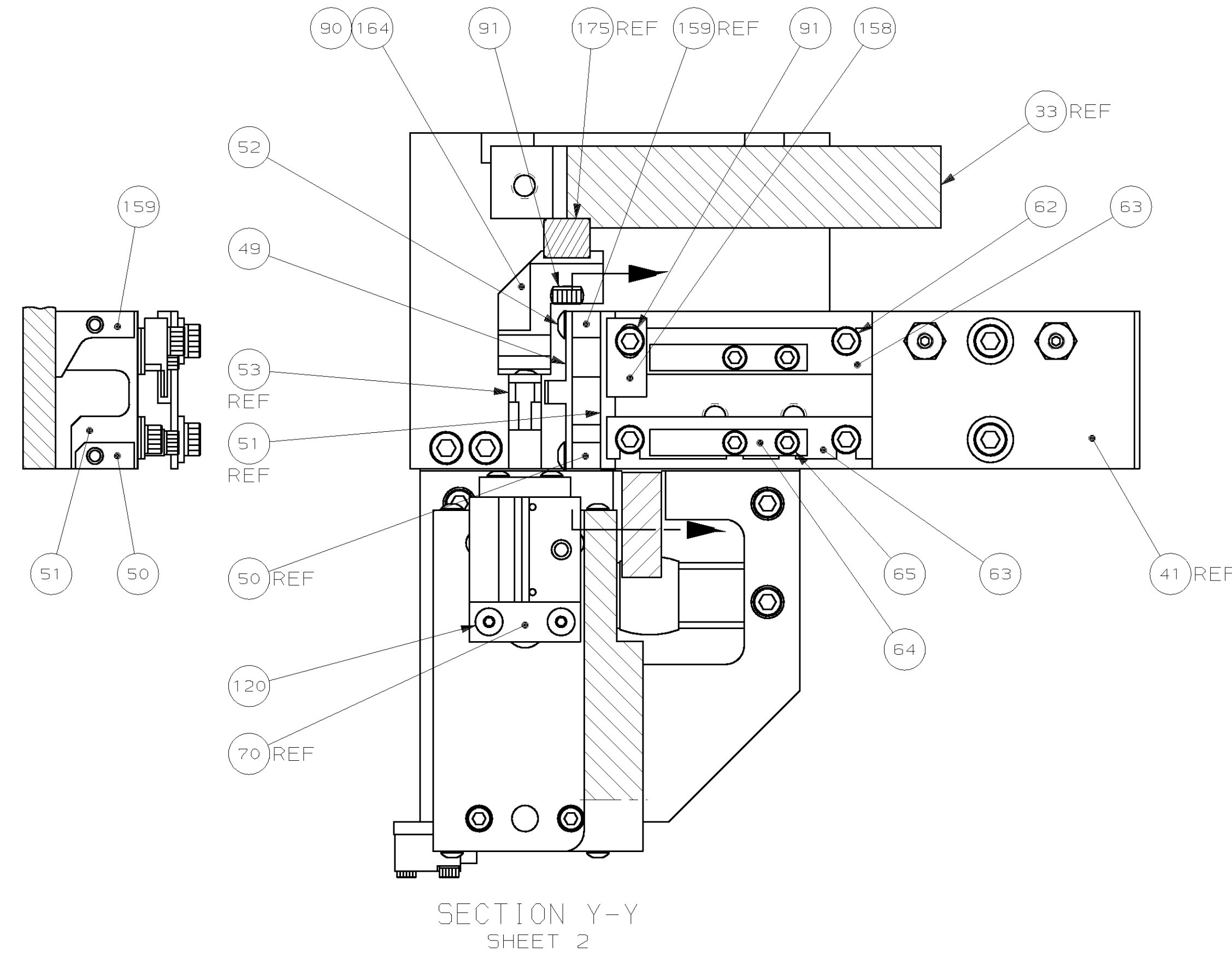

REV	DESCRIPTION	APP	DATE
1	SEE SHEET 1		

QTY	REQD PER ASSY	PART NO	DESCRIPTION	ITEM NO
REVISION OF EACH ASSY NO (WHEN BLANK, USE DWG REVISION)				
PARTS LIST				
MATL		HT TR		FIN
DIMENSIONS IN INCHES. DO NOT SCALE PRINT.				
TOLERANCES UNLESS OTHERWISE SPECIFIED:				
2 PLC DEC ± .25				
3 PLC DEC ±				
4 PLC DEC ±				
ANGLES ±				
SURF TEXTURE: ✓				
REMOVE BURRS, BREAK SHARP EDGES .015 R MAX				
SCALE	1:1	DWG NO	819528-1	SHEET 3 OF 4
CUSTOMER AND ASSEMBLY DRAWING 1			MACHINE REF CENTER STRIP MACHINE	
00779			REV M3	

819528-1

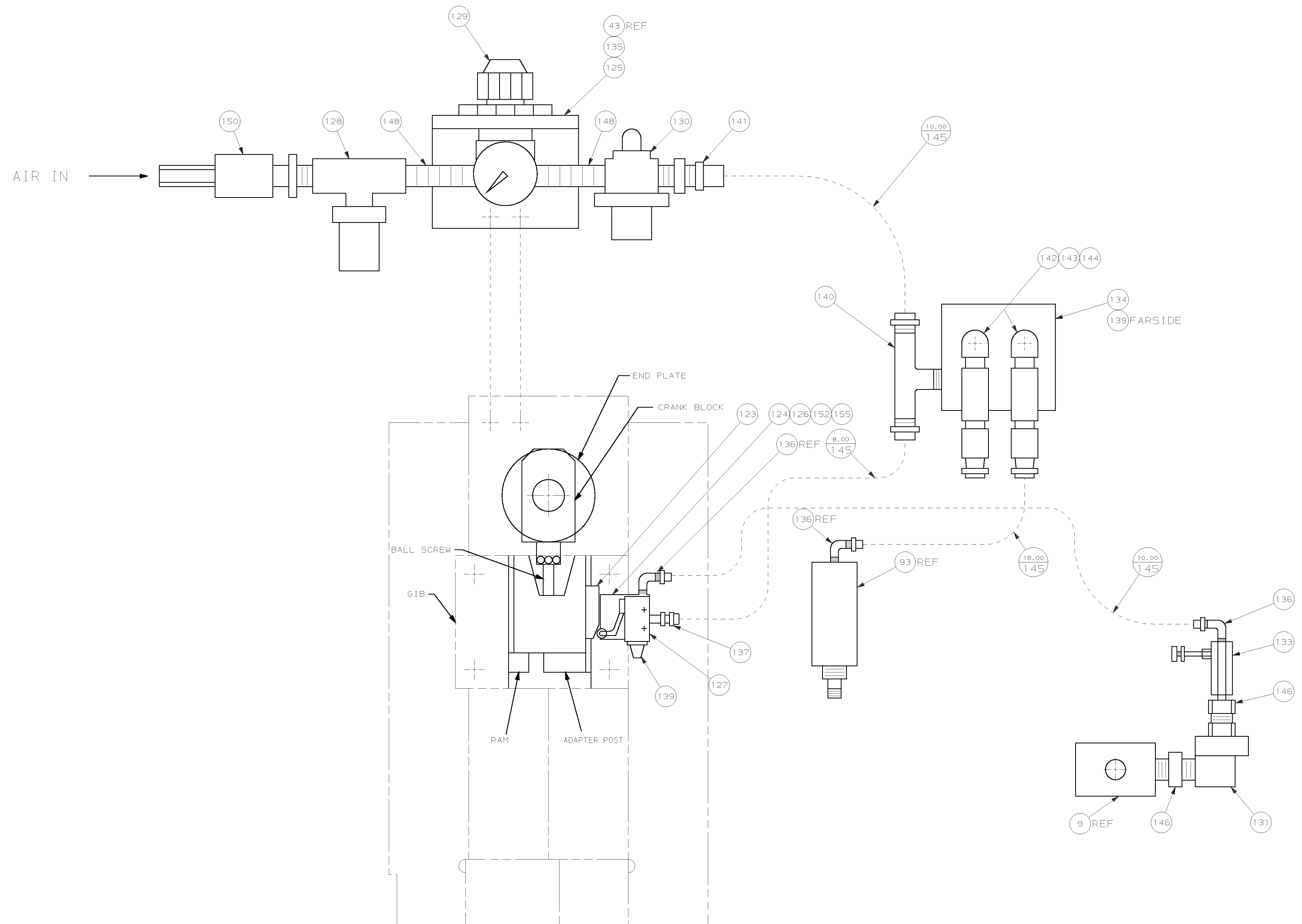

THIS DRAWING IS A CONTROLLED DOCUMENT.

THIS DRAWING IS UNRELEASED. RELEASED FOR PUBLICATION BY AMP INCORPORATED. ALL RIGHTS RESERVED.

LOC A
DIST 66

REV	DESCRIPTION	APP	DATE
1	SEE SHEET 1		

QTY	REQD PER ASSY	PART NO	DESCRIPTION	ITEM NO
REVISION OF EACH ASSY NO (WHEN BLANK, USE DWG REVISION)				
PARTS LIST				
MATL		HT TR		FIN
DIMENSIONS IN INCHES. DO NOT SCALE PRINT.				
TOLERANCES UNLESS OTHERWISE SPECIFIED:				
2 PLC DEC ± .25				
3 PLC DEC ±				
4 PLC DEC ±				
ANGLES ±				
SURF TEXTURE: ✓				
REMOVE BURRS, BREAK SHARP EDGES .015 R MAX				
SCALE	1:1	DWG NO	819528-1	SHEET 4 OF 4
CASE CODE	00779	CUSTOMER AND ASSEMBLY DRAWING 1		RESTRICTED TO



819528-1
D
C
B
A