

- 1 ZINC PER QQ-Z-363.
- 2 POLYMETHYLPENTENE PER ASTM-D-1238.
- 3 PHOSPHOR BRONZE PER QQ-B-750.
- 4 BRASS PER ASTM-B-453.
- 5 BRASS PER ASTM-B-16.
- 6 NICKEL PLATE PER QQ-N-290,  
3.81 μm [.000150] MINIMUM THICK.
- 7 TIN PLATE PER ASTM-B-545,  
3.81 μm [.000150] MINIMUM THICK.
- 8. SEE INSTRUCTION SHEET 408-2769.

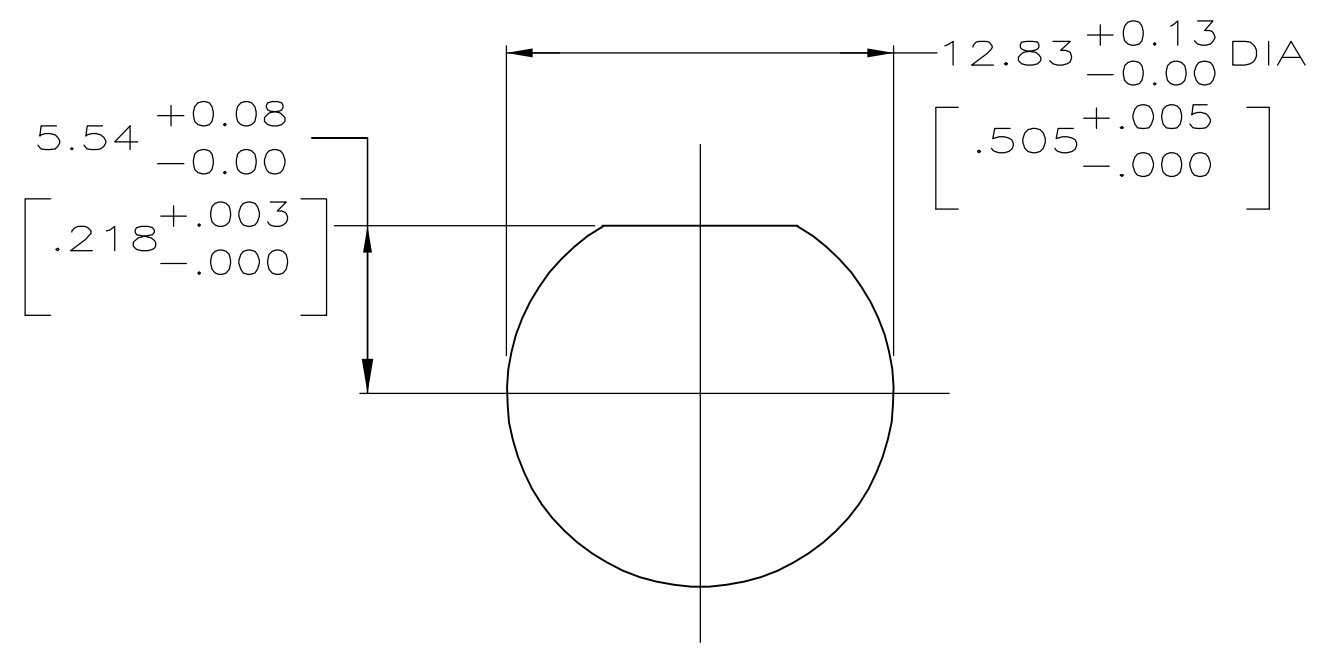

RECOMMENDED PANEL CUTOUT

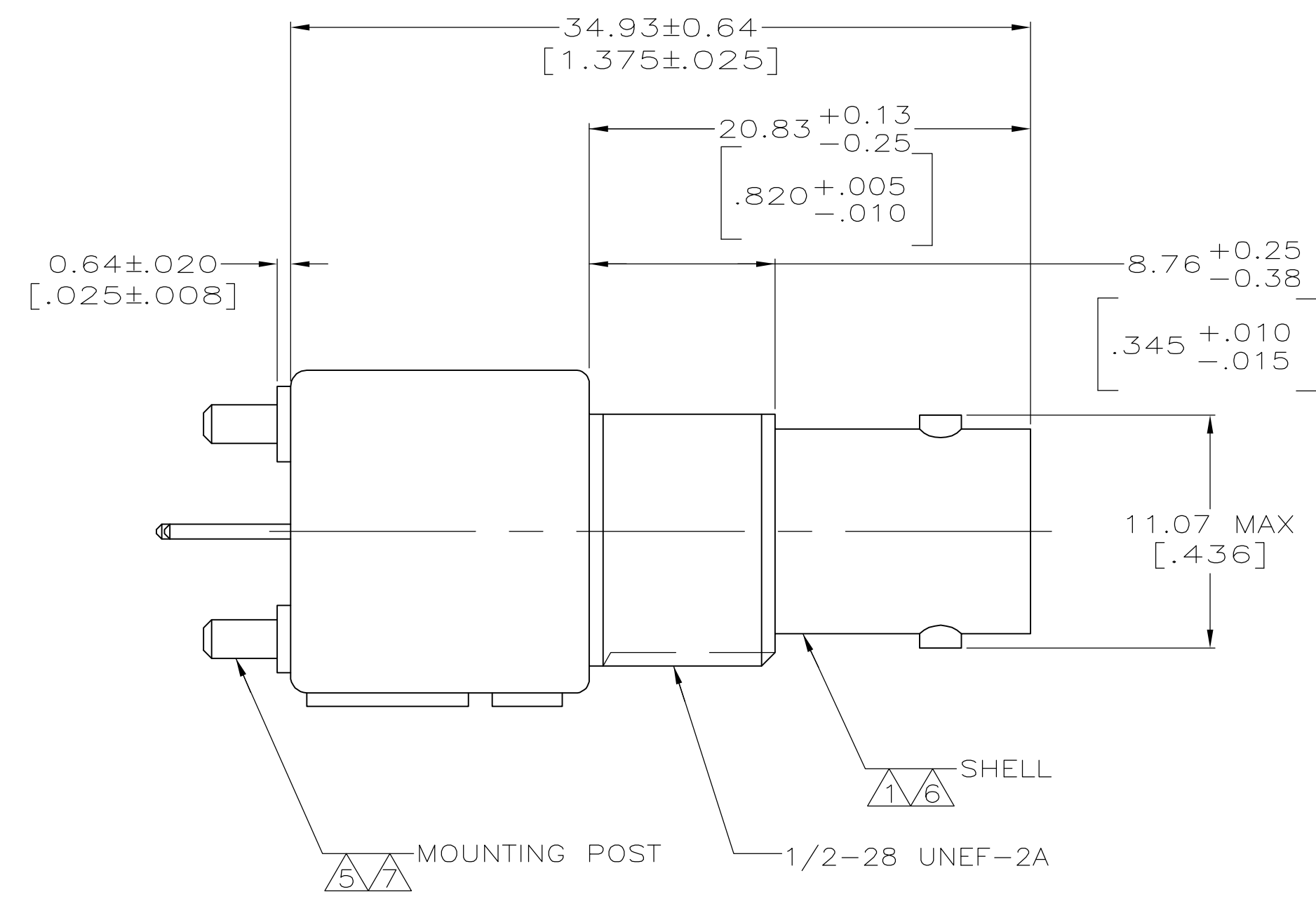
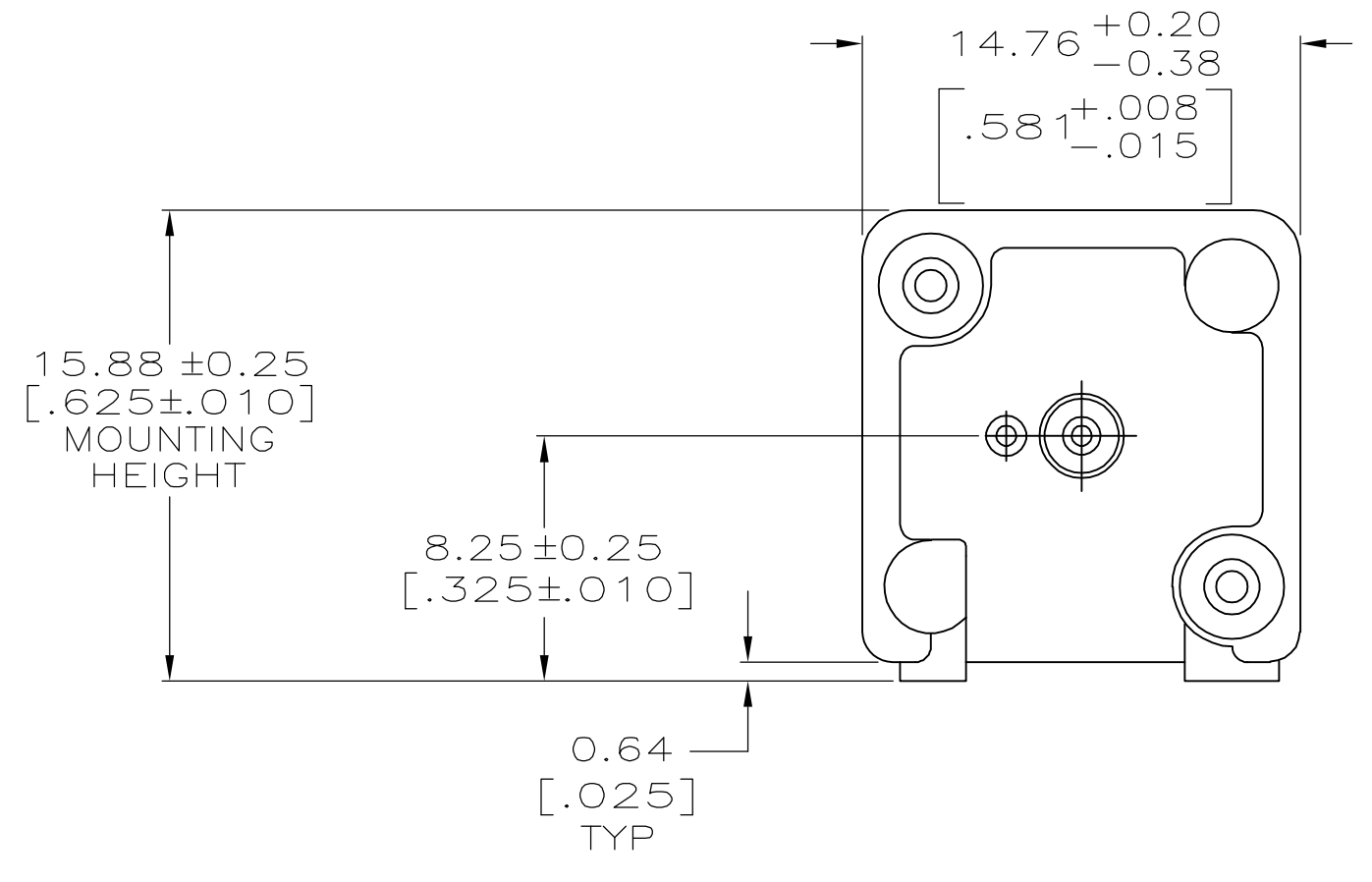
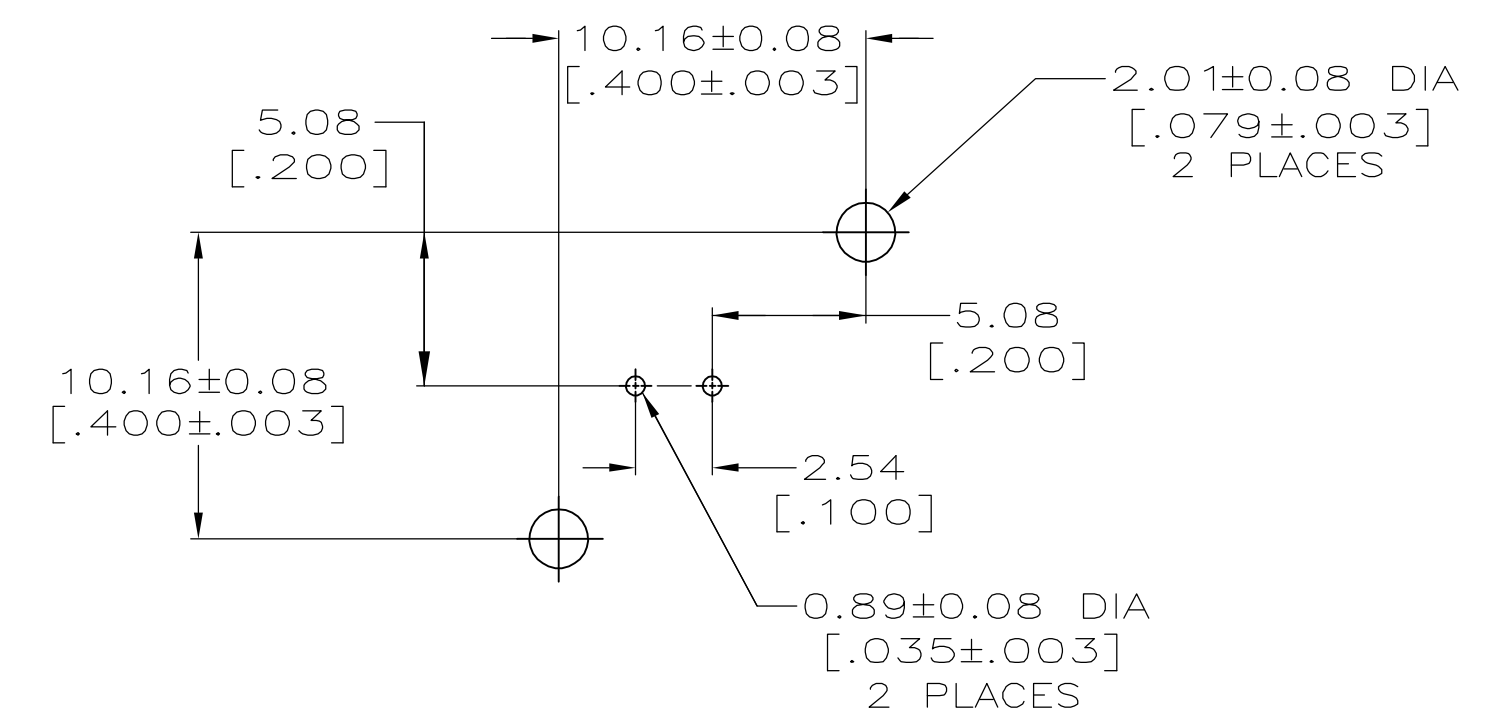

PCB CONFIGURATION

5227671-1  
PART NUMBER

THIS DRAWING IS A CONTROLLED DOCUMENT.		DWN L VARELA - 20APR2005		Tyco Electronics Corporation Harrisburg, Pa 17105-3608	
DIMENSIONS: mm [INCHES]		CHK J HAVENER - 20APR2005		APRO J LIPPERT - 20APR2005	NAME
TOLERANCES UNLESS OTHERWISE SPECIFIED:		PRODUCT SPEC		SIZE	108-12078
0 PLC ± -		APPLICATION SPEC		CAGE CODE	100779
1 PLC ± -		RESTRICTED TO		DRAWING NO	5227671
2 PLC ± 0.05 [.002]		WEIGHT		SCALE	4:1
3 PLC ± -		CUSTOMER DRAWING		SHEET	1 OF 1
4 PLC ± -		SCALE		REV	A
ANGLES ± -		SCALE			
FINISH SEE NOTES 6-8		SCALE			