

PART NUMBER	REV	FIRST USED
680133-1	B	854400-1
680133-2	B	565435-5
680133-3	B	354500-1

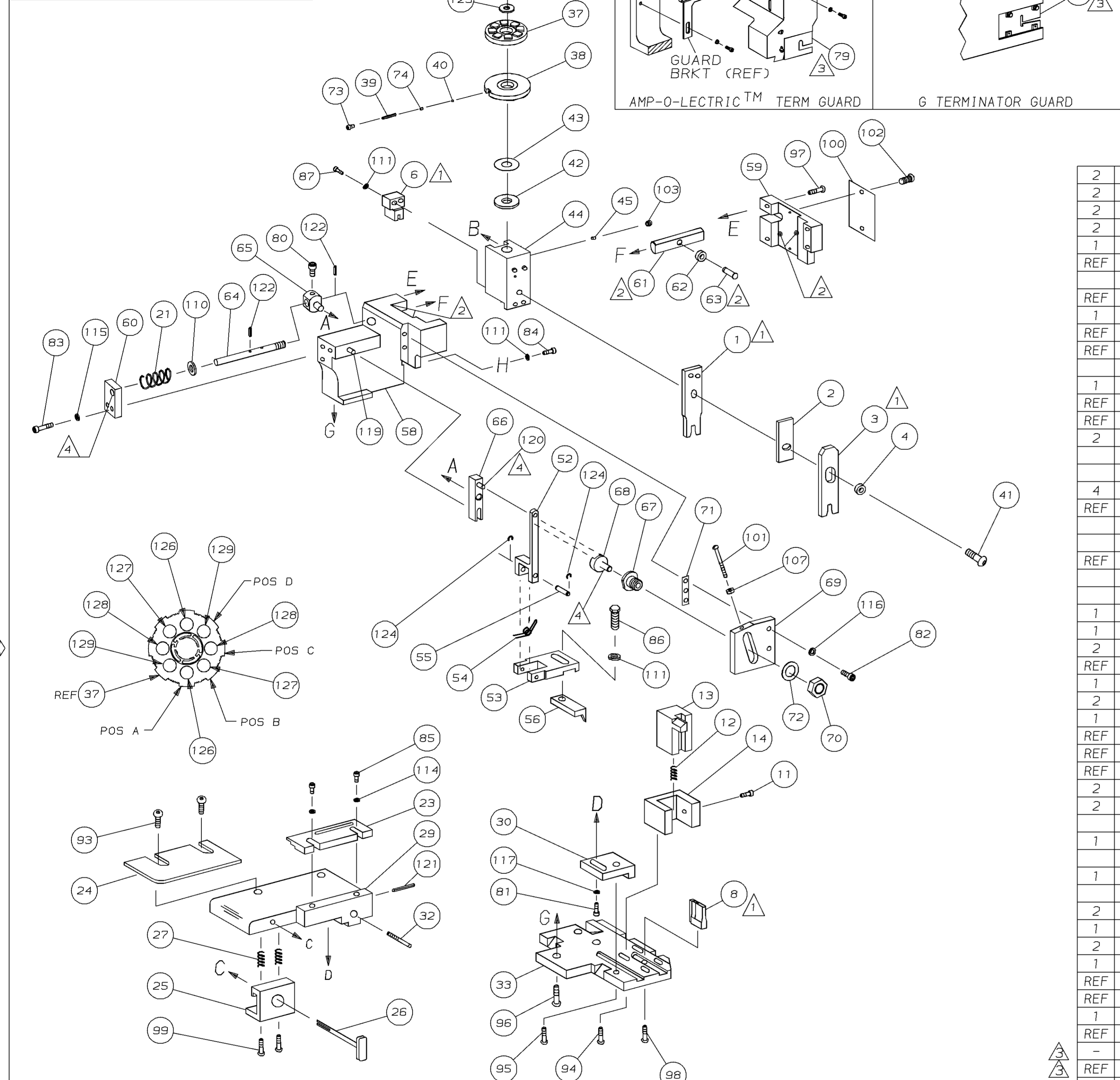

TERMINAL NAME:		REPT CONTACT, POWER SUPPLY	
			292002
TERM	APPL	SPEC	-

CRIMPING DATA			
PAD LTR	CRIMP HEIGHT	WIRE SIZE	
A	.051 ±.002	18	
B	.045 ±.002	20	
C	.042 ±.002	22	
D	.040 ±.002	24	
CRIMP	SIZE	TYPE	RANGE
WIRE	.070	F	24-18
INSUL	.100	0	.110 MAX
FEED	.309	APPL INST	SET UP GAGE LAYOUT
		408-8040	458637-1 L1612
WIRE STRIP LENGTH		-	

REV	LEADMAKER	MECH POST FEED		
-1	BENCH MODEL K	MECH PRE FEED		
-2	BENCH MODEL G	MECH PRE FEED		
REF	REF	REF	- B	22594-8 NUT, HEX (1/2-20)
REF	REF	REF	- B	240628-1 PLATE, ADJUSTMENT
REF	REF	REF	- B	240626-1 SHAFT, PIVOT
REF	REF	REF	- B	240633-1 BUSHING
REF	REF	REF	- A	455680-1 LEVER, INTERMEDIATE
REF	REF	REF	- B	240629-1 BLOCK, PIVOT
REF	REF	REF	- A	240632-2 SCREW, ADJ FEED ROD
REF	REF	REF	- B	240659-3 PIN, CAM ROLLER
REF	REF	REF	- B	240658-1 ROLLER, CAM
REF	REF	REF	- B	454398-2 ROD, FEED
REF	REF	REF	- A	454178-1 GUIDE, FEED ROD
REF	REF	REF	- C	454220-1 CAP, RAM
REF	REF	REF	- D	454485-1 HOUSING

2	2	2	-	C	3-354779-8	PIN, WIRE DISC (.3180)D	129
2	2	2	-	C	3-354779-4	PIN, WIRE DISC (.3160)C	128
2	2	2	-	C	2-354779-9	PIN, WIRE DISC (.3135)B	127
2	2	2	-	C	1-354779-5	PIN, WIRE DISC (.3065)A	126
1	1	1	-	A	986950-1	WASHER, FLAT PRECISION	125
REF	REF	REF	-	A	21045-3	RING, RET "C" (Ø.187)FD FING PIN	124
REF	REF	REF	-	A	5-21028-1	PIN, SLT SPR (Ø.125x.50)ADJ ROD	122
1	1	1	-	A	4-21028-0	PIN, SLT SPR (Ø.093x.75)ST GDE PL	121
REF	REF	REF	-	A	1-21030-1	PIN, DOWEL (Ø.187x.50)LEVER	120
REF	REF	REF	-	A	1-21030-6	PIN, DOWEL (Ø.187x1.25)HOUSING	119
1	1	1	-	A	21024-5	WASHER, LOCK (#10)ADJ BLOCK	118
REF	REF	REF	-	A	21024-5	WASHER, LOCK (#10)ADJ PLATE	117
REF	REF	REF	-	A	21024-5	WASHER, LOCK (#10)FEED GDE ROD	116
2	2	2	-	A	21024-2	WASHER, LOCK (#4)FRONT STP GUIDE	114
4	4	4	-	A	21024-4	WASHER, LOCK (#8)STRIPPER	111
REF	REF	REF	-	A	21899-4	WASHER, FLAT (Ø5/16)SCREW ADJ	110
REF	REF	REF	-	A	21018-5	NUT, HEX (6-32)FEED ADJ	107
1	1	1	-	A	992031-1	PIN, CLEVIS	104
1	1	1	-	A	21009-2	SCR, SKT SET (1/4-20x.25 LW)RAM	103
2	2	2	-	A	21017-2	SCR, DRIVE (#2x.19)ID PLATE	102
REF	REF	REF	-	A	6-23715-5	SCR, PAN HD (6-32x1.50)FEED ADJ	101
1	1	1	-	B	461264-1	PLATE, IDENTIFICATION	100
2	2	2	-	A	3-21002-0	SCR, BHC (10-32x.88)DRAG	99
1	1	1	-	A	22733-8	SCR, BHC (8-32x.38 LW)ANVIL	98
REF	REF	REF	-	A	2-21002-9	SCR, BHC (10-32x.75)CAP	97
REF	REF	REF	-	A	2-22733-8	SCR, BHC (1/4-20x.62)HOUSING	96
REF	REF	REF	-	A	2-21002-7	SCR, BHC (10-32x.50)SG ADJ BLOCK	95
2	2	2	-	A	2-21002-2	SCR, BHC (8-32x.50)SHEAR	94
2	2	2	-	A	2-21002-1	SCR, BHC (8-32x.38)R STRIP GUIDE	93
1	1	1	-	A	1-21002-7	SCR, BHC (6-32x.38)CAM	91
1	1	1	-	A	7-21000-9	SCR, SHC (4-40x.19)STRIPPER	89
2	2	2	-	A	2-21000-9	SCR, SHC (8-32x.75)DEP-HOLD	87
1	1	1	-	A	2-22603-0	SCR, HEX HD (8-32x.31)FEED FINGER	86
2	2	2	-	A	1-21000-4	SCR, SHC (4-40x.38)F ST GUIDE	85
1	1	1	-	A	2-21000-7	SCR, SHC (8-32x.50)STRIPPER	84
REF	REF	REF	-	A	3-21000-7	SCR, SHC (10-32x.75)FEED ROD GD	83
REF	REF	REF	-	A	3-21000-6	SCR, SHC (10-32x.62)FD ADJ BLK	82
1	1	1	-	A	3-21000-4	SCR, SHC (10-32x.38)SG ADJ BL	81
REF	REF	REF	-	A	3-21000-4	SCR, SHC (10-32x.38)PIVOT BLK	80
-	REF	-	-	B	455749-1	GUARD, WINDOW	79
REF	-	-	-	B	679532-1	INSERT, GUARD	78
1	1	1	-	A	690603-1	SPRING, ASSIST	74
1	1	1	-	A	23030-1	SCR, SHC (6-32x.25 SL)INS DISC	73
REF	REF	REF	-	A	458109-1	WASHER, SPECIAL	72
REF	REF	REF	-	A	690517-1	SPACER	71
-3	-2	-1	U/M	DWG SIZE	PART NO	DESCRIPTION	ITEM NO
REVISION OF EACH ASSY NO (WHEN BLANK, USE DWG REVISION)							
QTY REQD PER ASSY							

1	1	1	-	B	2-694433-9	PAWL, FEED	56
REF	REF	REF	-	B	240624-1	PIN, FEED FINGER	55
REF	REF	REF	-	B	691499-1	SPRING, FEED FINGER	54
REF	REF	REF	-	B	690541-1	HOLDER, FEED FINGER	53
REF	REF	REF	-	A	455679-1	LEVER, TERMINAL FEED ARM	52
1	1	1	-	B	690602-6	CAM, PRE-FEED 1 5/8 ST	49
-	1	-	-	B	690602-5	CAM, PRE-FEED 1 1/8 ST	48
-	-	1	-	B	690501-4	CAM, POST-FEED 1 5/8 ST	47
1	1	1	-	B	459456-1	APPLICATOR, BASIC (SUBASSY)	46
1	1	1	-	A	690191-1	PLUG, NYLON	45
1	1	1	-	C	455673-1	RAM	44
1	1	1	-	A	690125-1	WASHER, LAMINATED	43
1	1	1	-	A	690124-1	WASHER, RAM	42
1	1	1	-	A	7-21002-9	BOLT, CRIMPER (5/16x1.00)	41
1	1	1	-	A	23241-6	BALL, STEEL	40
1	1	1	-	A	690170-1	SPRING, COMPRESSION	39
1	1	1	-	C	690142-1	DISC, INSULATION	38
1	1	1	-	D	354777-1	WIRE DISC, PLASTIC	37
1	1	1	-	A	22480-5	WASHER, SPRING	36
1	1	1	-	B	690212-1	POST, RAM	35
REF	REF	REF	-	D	455675-1	PLATE, BASE	33
1	1	1	-	A	690432-3	SCREW, ADJUSTMENT	32
REF	REF	REF	-	B	455689-1	BLOCK, STRIP GUIDE ADJ	30
1	1	1	-	C	217821-1	PLATE, STRIP GUIDE	29
2	2	2	-	A	1-22284-0	SPRING, DRAG	27
1	1	1	-	B	690546-1	LEVER, DRAG RELEASE	26
1	1	1	-	B	224404-1	DRAG, TERMINAL	25
1	1	1	-	B	217817-1	GUIDE, STRIP (REAR)	24
1	1	1	-	B	217816-1	GUIDE, STRIP (FRONT)	23
-	-	1	-	B	690472-9	STRIPPER	22
REF	REF	REF	-	A	4-22284-9	SPRING, FEED RETURN	21
1	1	1	-	A	679218-1	STRIPPER WIRE STOP ASSY	20
1	1	1	-	B	458949-8	STRIPPER	19
1	1	1	-	C	217822-1	ANVIL	8
1	1	1	-	C	217820-1	BLADE, SHEAR	6
1	1	1	-	B	1-238009-2	SPACER, BLOCK CRIMPER	4
1	1	1	-	C	3-683454-1	CRIMPER, INSULATION	3
1	1	1	-	C	455888-3	SPACER, CRIMPER	2
1	1	1	-	C	3-456404-8	CRIMPER, WIRE	1
-3	-2	-1	U/M	DWG SIZE	PART NO	DESCRIPTION	ITEM NO
REVISION OF EACH ASSY NO (WHEN BLANK, USE DWG REVISION)							
QTY REQD PER ASSY							

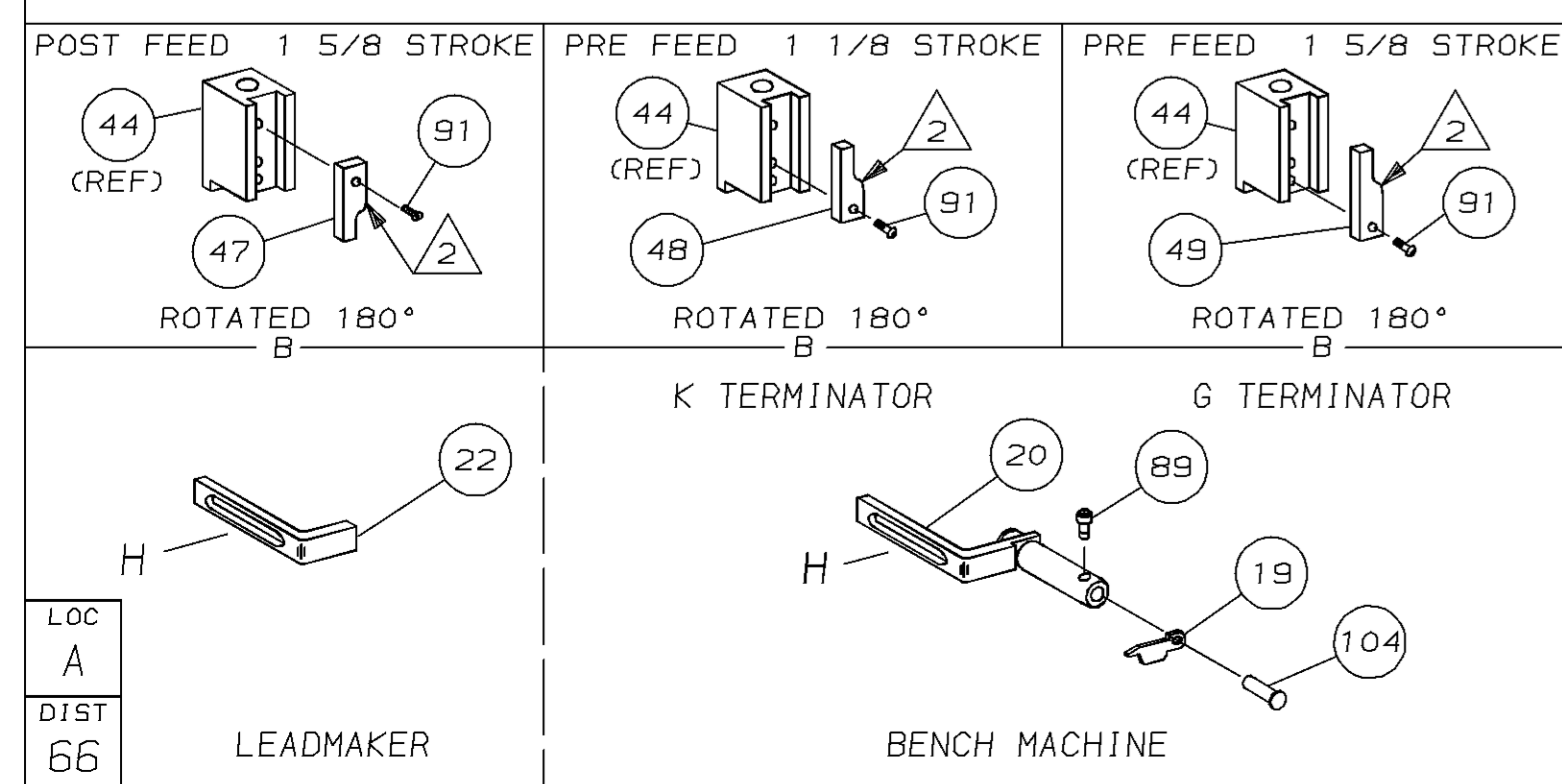

- 1 RECOMMENDED SPARE PARTS.
- 2 GREASE LIGHTLY.
- 3 GUARD MUST BE IN PLACE WHEN OPERATING APPLICATOR IN A BENCH MACHINE.
- 4 LUBRICATE DAILY USING NO. 20 MACHINE OIL.
- 5. ITEMS WITH QTY OF REF SPECIFIED (EXCEPT ITEMS 78 AND 79) ARE USED ON ITEM 46.

THIS INFORMATION IS CONFIDENTIAL AND IS DISCLOSED TO YOU ON CONDITION THAT NO FURTHER DISCLOSURE IS MADE BY YOU TO OTHER THAN AMP PERSONNEL WITHOUT WRITTEN AUTHORIZATION FROM AMP INCORPORATED, HARRISBURG, PA.

THIS DRAWING IS A CONTROLLED DOCUMENT FOR AMP INCORPORATED. IT IS SUBJECT TO CHANGE AND THE CONTROLLING ENGINEERING ORGANIZATION SHOULD BE CONTACTED FOR THE LATEST REVISION.