

SHARP

REFERENCE
SPEC. No. ED-02C009
ISSUE Aug 4, 2003

OPTO-ELECTRONIC DEVICES DIVISION
ELECTRONIC COMPONENTS GROUP
SHARP CORPORATION

SPECIFICATION

DEVICE SPECIFICATION FOR

MODEL No. Fiber-optic for digital audio interface
GP1FA514TZ

Specified for

Enclosed please find copies of the Specifications which consists of 11 pages including cover.
After confirmation of the contents, please be sure to send back copies of the Specifications
with approving signature on each.

CUSTOMER'S APPROVAL

DATE

BY

PRESENTED

DATE

BY *H. Ogura*

H. Ogura,
Department General Manager of
Engineering Dept., III
Opto-Electronic Devices Div.
ELECOM Group
SHARP CORPORATION

REFERENCE

Product name : Fiber-optic for digital audio interface

Model No. : GPIFA514TZ

1. These specification sheets include materials protected under copyright of Sharp Corporation ("Sharp"). Please do not reproduce or cause anyone to reproduce them without Sharp's consent.
2. When using this product, please observe the absolute maximum ratings and the instructions for use outlined in these specification sheets, as well as the precautions mentioned below. Sharp assumes no responsibility for any damage resulting from use of the product which does not comply with the absolute maximum ratings and the instructions included in these specification sheets, and the precautions mentioned below.

(Precautions)

- (1) This product is designed for use in the following application areas ;

• OA equipment • Audio visual equipment • Home appliances
• Telecommunication equipment (Terminal) • Measuring equipment
• Tooling machines • Computers • Amusement equipment etc.

If the use of the product in the above application areas is for equipment listed in paragraphs (2) or (3), please be sure to observe the precautions given in those respective paragraphs.

- (2) Appropriate measures, such as fail-safe design and redundant design considering the safety design of the overall system and equipment, should be taken to ensure reliability and safety when this product is used for equipment which demands high reliability and safety in function and precision, such as ;

• Transportation control and safety equipment (aircraft, train, automobile etc.)
• Traffic signals • Gas leakage sensor breakers • Rescue and security equipment
• Other safety equipment etc.

- (3) Please do not use this product for equipment which require extremely high reliability and safety in function and precision, such as ;

• Space equipment • Telecommunication equipment (for trunk lines)
• Nuclear power control equipment • Medical equipment etc.

- (4) Please contact and consult with a Sharp sales representative if there are any questions regarding interpretation of the above three paragraphs.

3. Please contact and consult with a Sharp sales representative for any questions about this product.

REFERENCE

1. Application

This specification applied to the outline and characteristics of the fiber-optic transmitter unit with shutter GP1FA514TZ for digital audio interface.

2. Outline

Refer to the attached drawing No. CY11727i02.

3. Ratings and characteristics

Refer to the attached sheet, Page 4 to 6.

4. Reliability

Refer to the attached sheet, Page 7.

5. Outgoing inspection

Refer to the attached sheet, Page 8.

6. Supplements

6.1 Packing specification : Refer to the attached sheet, Page 10.

6.2 To evaluate the characteristics, the Sharp GP1FA513RZ or its equivalent receiver shall be used as the standard receiver and the Sharp GP1C331 (APF,1m) or its equivalent fiber optic cable shall be used as the standard fiber optic cable.

6.3 This product is not designed to protect against electromagnetic waves or heavily charged electric particles.

6.4 This product shall not contain the following materials.

Also, the following materials shall not be used in the production process for this product.

Materials for ODS : CFCs, Halon, Carbon tetrachloride 1.1.1-Trichloroethane (Methylchloroform)

6.5 Product mass : Approx. 3g

7. Notes

Refer to the attached sheet, Page 9.

Symbol	Description	Material
A	Holder	PBT (color: Black)
B	Holder	ABS (color: Black)
C	Shutter	ABS (color: Black)
D	Fixing pin	PBT (color: Black)
E	Lead pin	Cu Alloy (Solder plating finish)

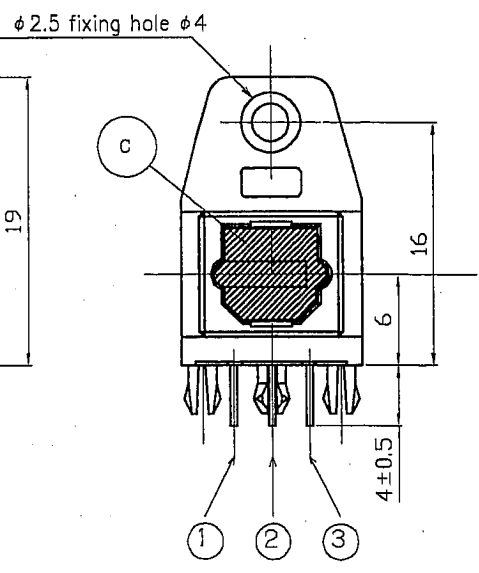
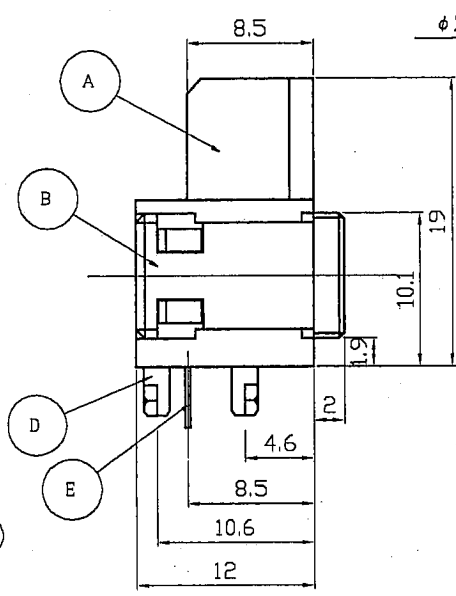
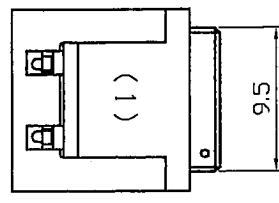
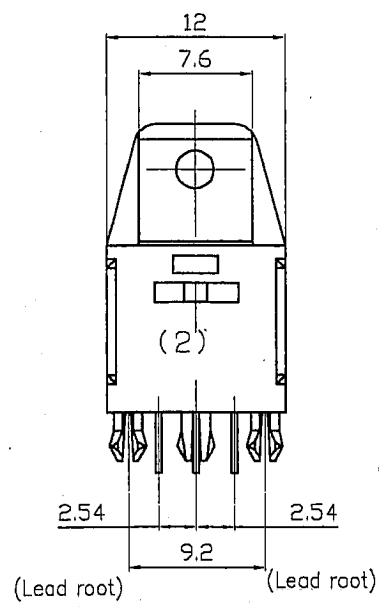

Example of mounting drawing from solder side
Unspecified tolerance ±0.1

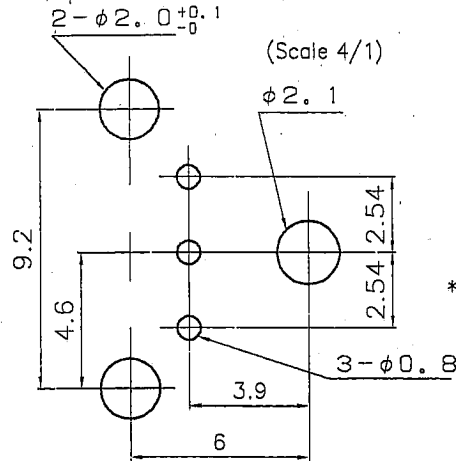

Internal equivalent circuit

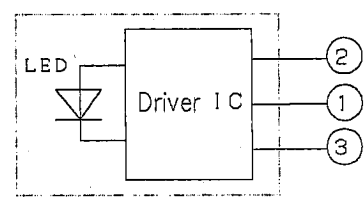

LED : GaAlAs
Driver IC : Silicon

Pin arrangement

- ① V_{in} *1
- ② VCC
- ③ GND

*1 Input conditions of V_{in} terminal are designed to conform to TTL and CMOS. We recommend that the input for V_{in} terminal uses the output of TTL and high speed CMOS.

- 4) We have SHARP's products which the shape of fixing pin to PCB is different from this transmitter. So, please understand that example of drawing for this transmitter.
- 3) Unspecified tolerance shall be ±0.3.

(2) Portion marking

Production year (Last digit of prod. year)

Production month

- Jan. to Sep.: 1~9
- Oct.: X
- Nov.: Y
- Dec.: Z

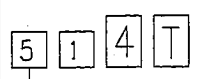

A part of Model No.

- 2) (1) portion: "S" mark (2) portion: A part of Model No. and date code shall be indicated
- 1) The connector joint area complies with the square connector EIAJ RC-5720B.

SCALE	NAME	Fiber-optic for digital audio interface	
2/1		GP1FA514TZ	
UNIT		Outline Dimensions	
1 = 1/1 mm	DRAWING No.	CY	11727i02

3. Ratings and Characteristics

3.1 Absolute maximum ratings

Parameter	Symbol	Ratings	Unit	Remarks
Supply voltage	Vcc	-0.5 to +7.0	V	
Input voltage	Vin	-0.5 to Vcc+0.5	V	
Operating temperature	Topr	-20 to 70	°C	
Storage temperature	Tstg	-30 to 80	°C	
Soldering temperature	Tsol	260	°C	5s /time up to 2 times

3.2 Recommended operating conditions

Parameter	Symbol	MIN.	TYP.	MAX.	Unit	Remarks
Supply voltage	Vcc	4.75	5.0	5.25	V	
Operating transfer rate	T	-	-	13.2	Mb/s	NRZ signal, duty 50%

3.3 Electro-optical characteristics

Ta=25°C, Vcc=5.0V

No.	Parameter	Symbol	Conditions	MIN.	TYP.	MAX.	Unit
1	Peak emission wavelength	λ_p		630	660	690	nm
2	Output optical power couple into fiber	Pc	Measuring method Refer to 3.4.1	-21	-18	-15	dBm
3	Supply current	Icc		-	8	13	mA
4	High level input voltage	ViH	Measuring method Refer to 3.4.2	2.0	-	-	V
5	Low level input voltage	ViL		-	-	0.8	V
6	L→H delay time	tpLH		-	-	180	ns
7	H→L delay time	tpHL		-	-	180	ns
8	Pulse width distortion	Δtw	Measuring method Refer to 3.4.3	-15	-	+15	ns
9	Jitter	Δtj		-	1	15	ns

REFERENCE

3.4 Measuring method

3.4.1 Fiber coupling light output measuring method

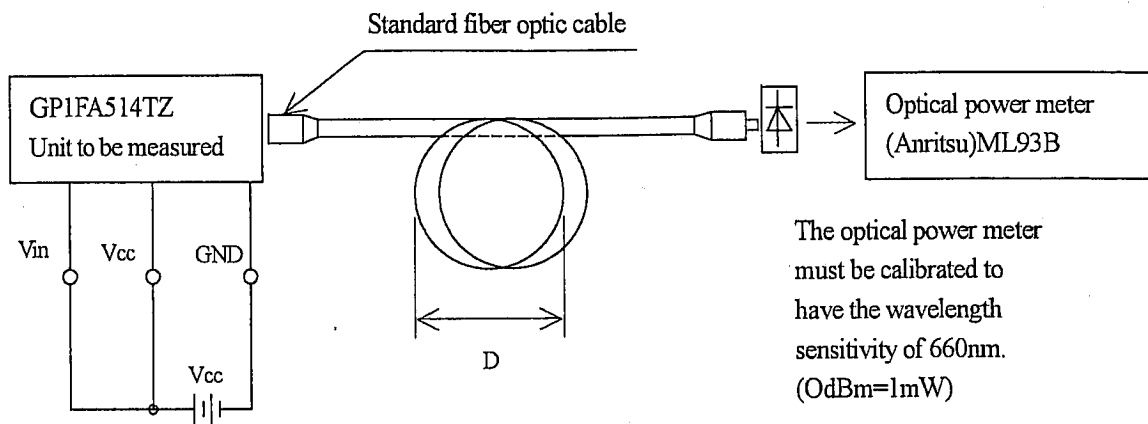

The optical power meter must be calibrated to have the wavelength sensitivity of 660nm. (OdBm=1mW)

Notes (1) V_{cc} ; 5.0V (State of operating)

(2) To bundle up the standard fiber optic cable, make it into a loop with the diameter $D=10\text{cm}$ or more. (The standard fiber optic cable will be specified elsewhere.)

3.4.2 Input voltage and supply current measuring method

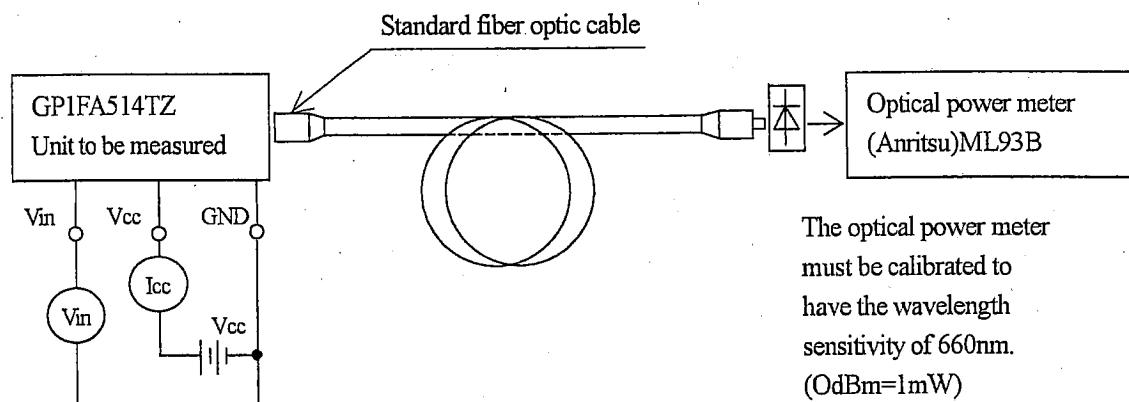

The optical power meter must be calibrated to have the wavelength sensitivity of 660nm. (OdBm=1mW)

Input conditions and judgement method

No.	Input conditions	Judgement method
1	$V_{in}=2.0\text{V}$ or more	$-21 \leq P_c \leq -15\text{dBm}$, $I_{cc}=13\text{mA}$ or less
2	$V_{in}=0.8\text{V}$ or less	$P_c \leq -36\text{dBm}$, $I_{cc}=13\text{mA}$ or less

Note (1) $V_{cc}=5.0\text{V}$ (State of operating)

REFERENCE

3.4.3 Measuring method of pulse response and Jitter

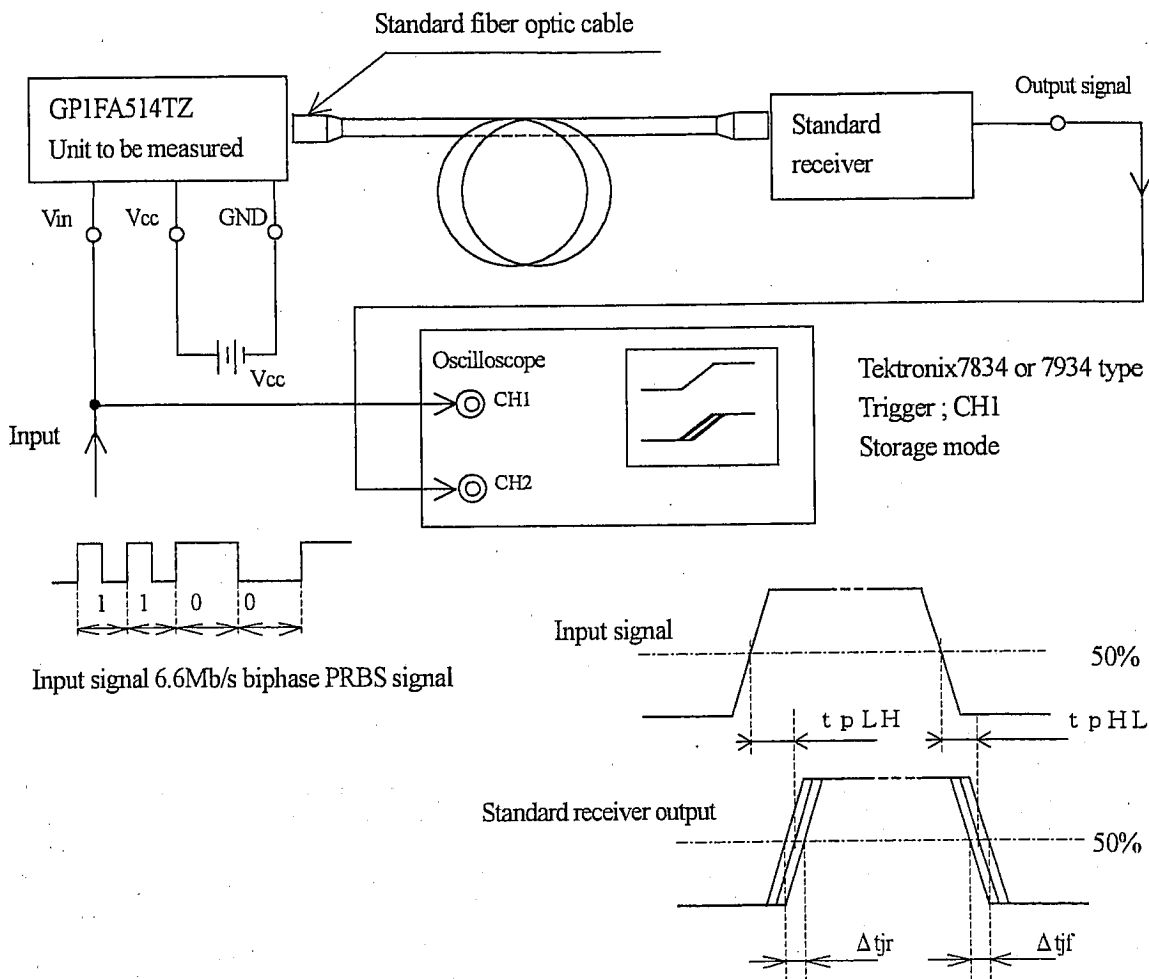

Test item

No.	Test item	Symbol	Test conditions
1	L→H pulse delay time	t_{pLH}	It is defined by drawing in 6/10 page.
2	H→L pulse delay time	t_{pHL}	It is defined by drawing in 6/10 page.
3	Pulse width distortion	Δtw	$\Delta tw = t_{pHL} - t_{pLH}$
4	L→H Jitter	Δt_{jr}	Set the trigger on the rise of input signal to measure the jitter of the rise of output.
5	H→L Jitter	Δt_{jf}	Set the trigger on the fall of input signal to measure the jitter of the fall of output.

- (1) The wave form write time shall be 4s. But do not allow the wave form to be distorted by increasing the brightness too much.
- (2) $V_{cc} = 5.0V$ (State of operating)
- (3) The probe for the oscilloscope must be more than $1M\Omega$ and less than $10pF$.

3.5 Mechanical characteristics

Parameter	Symbol	MIN.	TYP.	MAX.	Unit	Condition
Insertion force, withdrawal force	-	6	-	40	N	Initial value when GPIC331 is used

REFERENCE

4. Reliability

The reliability of products shall satisfy items listed below.

Confidence level : 90%

LTPD : 10 or 20

No.	Test Items	Test Conditions	Failure Judgement Criteria	Samples (n)
				Defective(C)
1	High temp. and high humidity storage	Ta=40°C, 90%RH, 500h	Failure judgement criteria of each characteristics given in 3.3 No. 2 to 9 must be with the following range.	n=22, C=0
2	High temp. storage	Ta=80°C, 500h		n=22, C=0
3	Low temp. storage	Ta=-30°C, 500h		n=22, C=0
4	Temperature cycling	Ta=-30°C to +80°C (30min) (30min) 20 cycles test		n=22, C=0
5	High temp. operation life	Ta=60°C, Vcc=5V applying 500h	No. 3 to 7, 9 L×0.8 or less	n=22, C=0
6	Soldering heat	Tsol=260°C, 5 s/2 times	U×1.2 or more	n=11, C=0
7	Terminal strength (Tension)	Weight : 5N 30 s/each terminal	No. 2 L×1.2 or less	n=11, C=0
8	Terminal strength (Bending)	Weight : 2.5N 0° →90° →0° 2 times/each terminal	U×0.8 or more	n=11, C=0
9	Shock	1000m/s ² Pulse width: 6ms X, Y, Z/3 times each	No. 8 L×1.2 or less U×1.2 or more	n=11, C=0
10	Vibration	Frequency range: 10 to 55Hz/sweep 1min Overall amplitude: 1.5mm X, Y, Z/2h each	U: Upper specification limit L: Lower specification limit	n=11, C=0
11	Repeated operation	500 times (Fiber optic cable GP1C331 used)	Insertion force ≥40N 4N ≥ withdrawal force 40N ≤ withdrawal force	n=11, C=0
12	Repeat open/close operation of shutter	1000 times (Fiber optic cable GP1C331 used)	※1	n=11, C=0

※1 Shutter open/close function shall be no trouble. Shutter shall be no damage.

4.1 Measurement conditions

In the test 1 to 6 above, to measure the characteristics, leave 2h at normal temperature and humidity after being tested.

REFERENCE

5. Outgoing inspection

(1) Inspection lot

Inspection shall be carried out per each delivery lot.

(2) Inspection method

A single sampling plan, normal inspection level II based on ISO 2859 shall be adopted.

Parameter	Inspection items		AQL(%)
Major defect	1	Satisfies electro-optical characteristics in parameter 3.3 (No.2 to 9).	0.4
	2	It should have no disconnection of lead terminal and case terminal. It should have no dust and solder that would hinder PCB insertion.	
	3	Free from foreign matter on the connector coupling portion that would hinder plug insertion.	
Minor defect	1	Deformation of case and lead terminal (Satisfying outline dimensions of parameter 2)	1.5
	2	Stamp (It should be possible to read stamp of parameter 2. Stamp should be indicated at fixed position.)	

7. Notes

- (1) The stabilization of the power supply line
Connect a by-pass capacitor ($0.1 \mu F$) of one piece per one element close to the GP1FA514TZ within 7mm of the unit lead terminal. (And connect a $4.7 \mu F$ capacitor of one piece per one element across the power supply line.)
- (2) Soldering condition
No more than two times of less than 5 seconds each at soldering temperatures not exceeding $260^{\circ}C$.
Check your soldering condition damaged device and do not getting stress in the lead terminal in case of using soldering rod.
In case of using flow soldering, please make sure of the conditions of process at the flow equipment.
(Solder at a position more than 1.6mm away from the base of the lead terminal.)
Please don't do soldering by reflow.
- (3) Incoming dirt and dust inside connector coupling portion
Dirt and dust in the jack junction portion, if any, must be blown off by a blower opening with shutter portion.
Do not insert any rigid rod-like object into the connector junction.
The device inside might get damaged resulting deteriorated characteristics.
- (4) Cleaning
Do not immerse when cleaning. The solvent would get into the connector coupling portion resulting deteriorated characteristics.
Should it be necessary to remove the flux, use one of the following solvents only to be applied with a brush.
Solvent ... Isopropyl alcohol, Methyl alcohol
- (5) Grand on assembly process
The human body and the soldering rod must be grounded against the static breakdown of the IC during assembling.
Avoid as much as possible touching the IC terminals before assembling.
- (6) Fixing product
Please fix this device with M3.0 screw. In case that this device is not fixed fully, there is the possibility that characteristics deteriorates by stress to be given to internal device and lead wire portion when connector detaching. The tightening torque of M3.0 screw for fixing this device shall be 0.25 to $0.4N \cdot m$.
However, in case of fixing with screw, Please confirm the limit of fixing strength to the fixed object before fixing actually.
In case of fixing the device with screw by screwdriver etc., if excessive force by screwdriver etc. is applied to the holder or internal devices, the performance might fall down. Please be careful at work.
(ref: the force applied by driver etc. shall be $39N$ or less for safety.)
- (7) Input signal
This transmitter is designed intentionally based upon the signal transmission which is defined by the digital audio interface standard ; CP-1201.
When signal out of ELAJ standard CP-1201 is inputted to this transmitter, there are cases that this transmitter can not transmit normally signal to receiving unit.
- (8) Foot print to fix
We have SHARP's products which the shape of fixing pin to PCB is different from this transmitter.
So please understand that example of mounting hole drawing for this transmitter shown in outline dimensions.
- (9) Damage to connector coupling portion
Please take care for force provided to connector coupling portion of this transmitter, such as deformation of connector coupling portion.
Because there are cases that shutter window can't open and shut in normally.
- (10) About getting the solvent into connector coupling portion
Please do not get the solvent into connector coupling portion of this transmitter.
Because there are cases that the characteristics deteriorated and the shutter window can't open and shut in normally.

REFERENCE

Packing specification

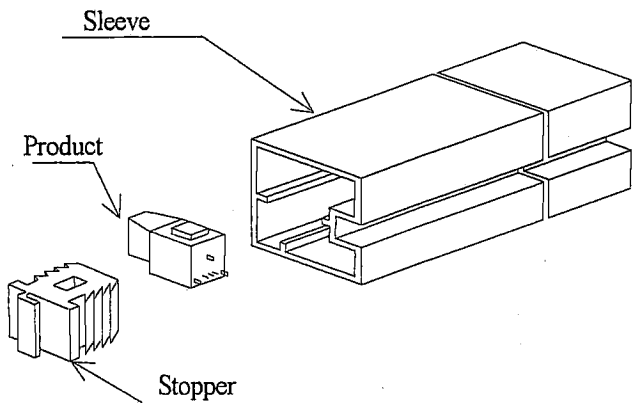

(Fig. 1)

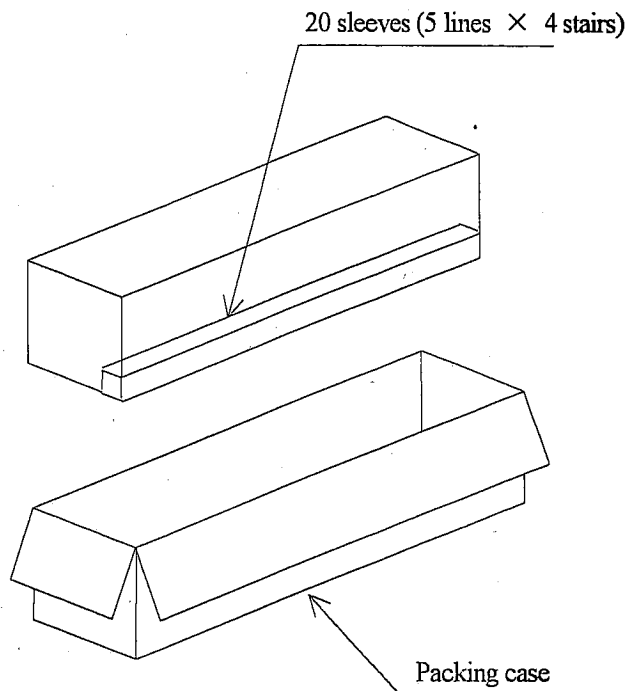

(Fig. 2)

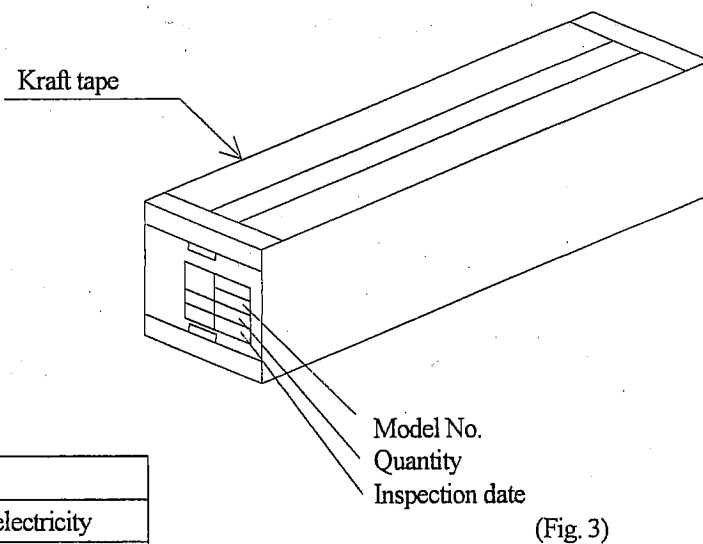

(Fig. 3)

Parts name	Material
Sleeve	HIPS with preventing static electricity
Stopper	Styrene butadiene rubber 45
Packing case	Corrugated cardboard

Packaging method

1. Products of appointed quantity shall be packaged in a sleeve and both of sleeve edge shall be fixed by stopper. Fig. 1
(GP1FA514TZ : 50 pcs.)
2. 20 sleeves shall be packaged in a packing case. Fig. 2
3. Fix the packing case by kraft tape, and fill in the blanks of Model No., Quantity and Inspection date. Fig. 3
(Quantity per a packing case : 1000pcs.)

Formal packaged mass : Approximately 5.4kg