

LOC	DIST	P	F	ZONE	LTR	REVISIONS	DATE	APPD
AF	50				C	REVISED & REDRAWN PER 0710-0455-94	14/JAN/95	MF/NN

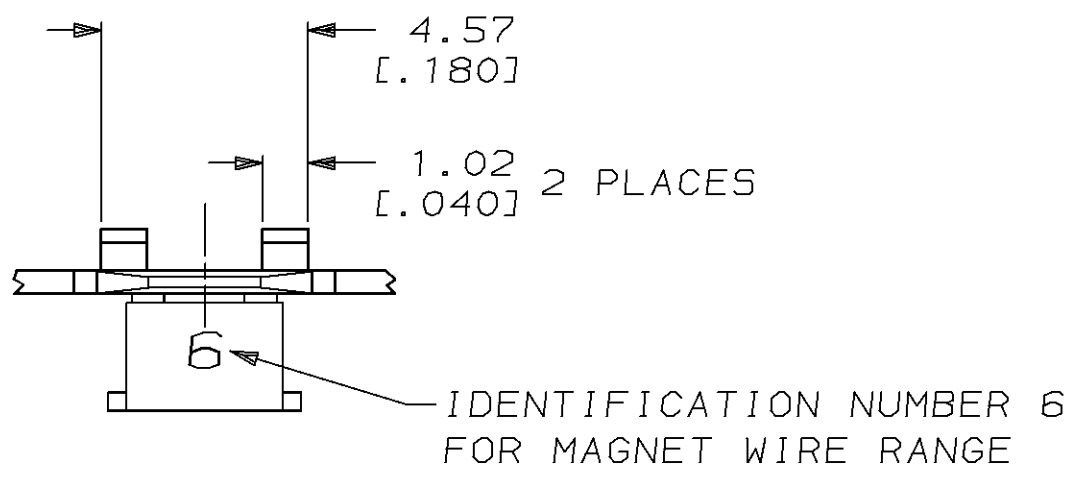

1 CONTINUOUS STRIP ON REELS WITH TERMINALS LOCATED ON 8.38±0.08 [.330±.003] CENTERS.
 2 SLOT ACCEPTS 0.25-0.36mm [#30-#27] AWG COPPER MAGNET WIRE.
 2 WIRES OF THE SAME SIZE MAX PER SLOT.

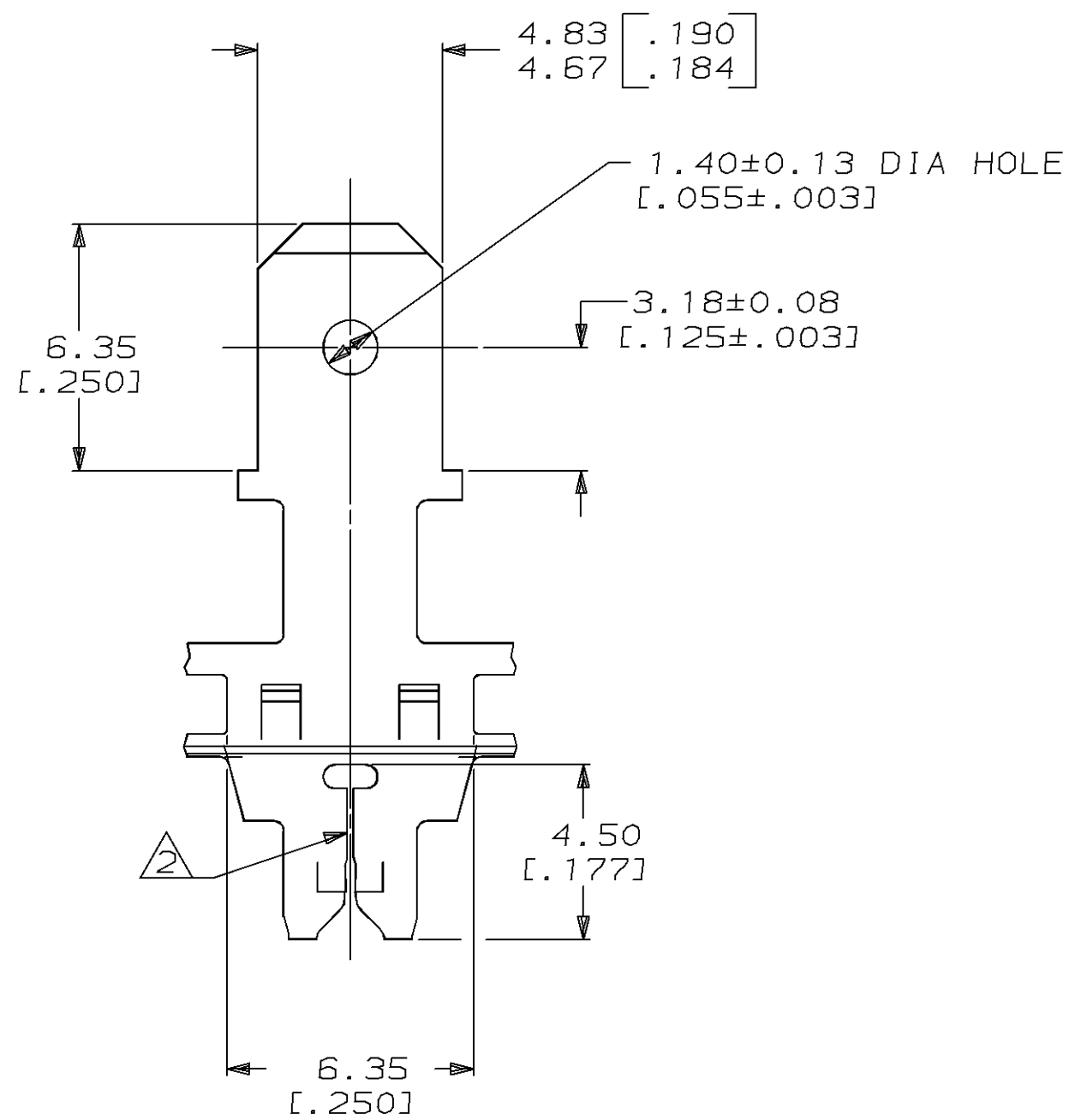
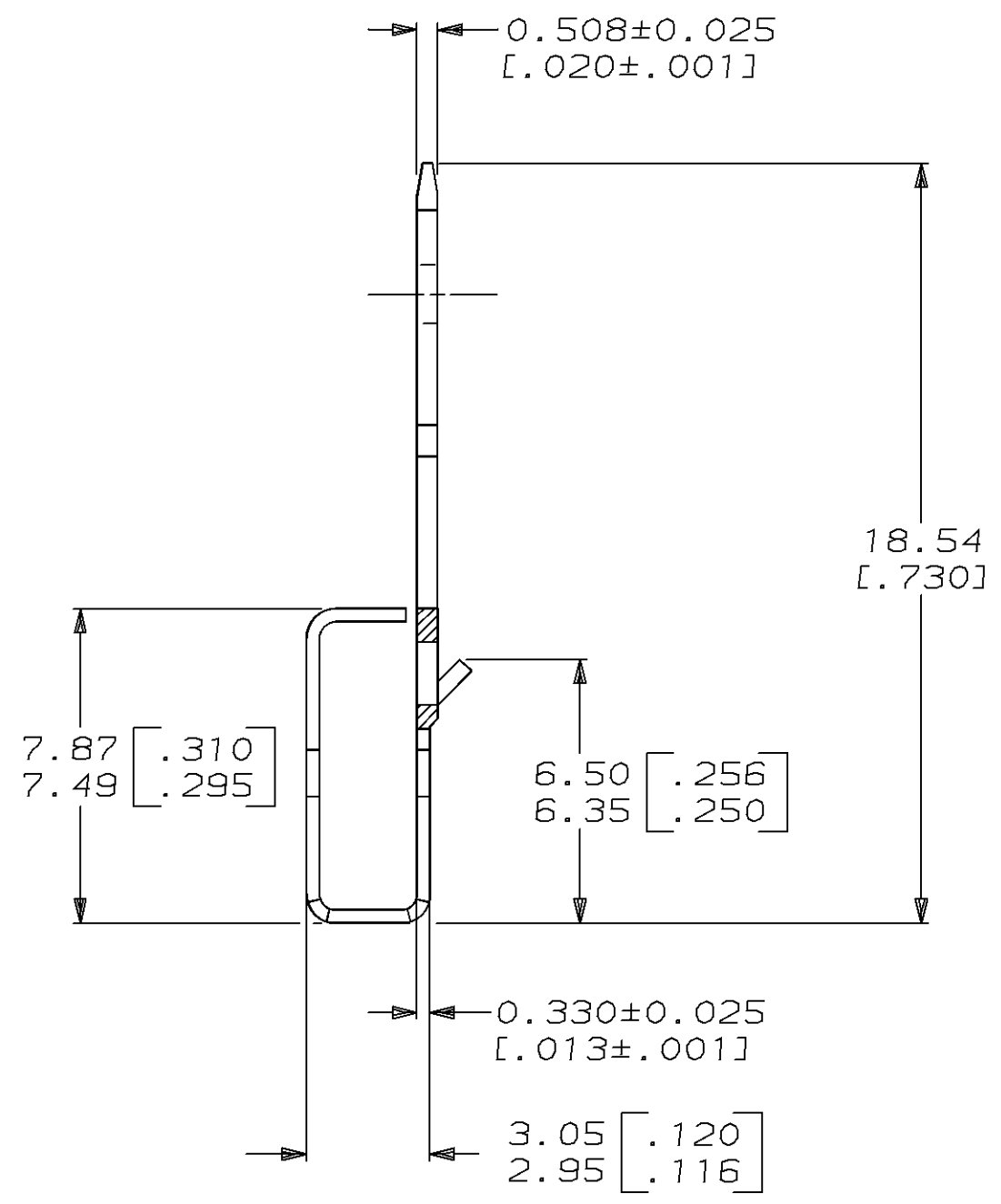
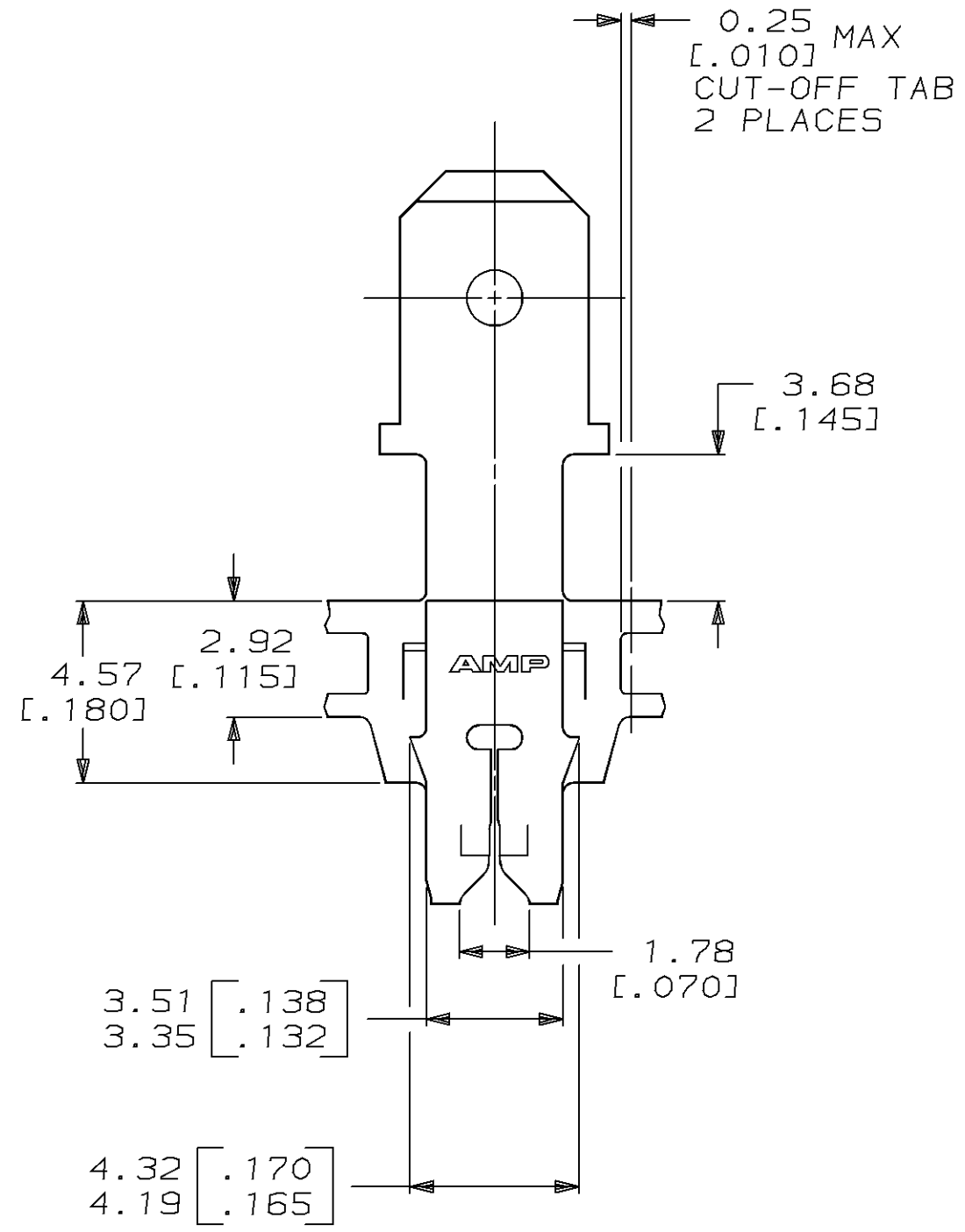

63447-1
 PART NO

DO NOT SCALE PRINT. UNLESS SPECIFIED DIMENSIONS IN mm [INCHES] TOLERANCES ON: 2 PLC DEC ± 0.25 [.010] 3 PLC DEC ± - ANGLES ± -		DR 14/JAN/95 MICHAEL S. FEHER		AMP Incorporated Harrisburg, PA 17105-3608	
MATERIAL 4M PRE-MILLED BRASS		CHK 16/JAN/95 PHILLIP M. FORTNEY			
FINISH 0.002032 [.000080] MIN TIN PER MIL-T-10727		APPD 16/JAN/95 NELSON E. NEFF		NAME TAB, 4.75 [.187] FASTON™ MAG-MATE™	
THIS DRAWING IS A CONTROLLED DOCUMENT FOR AMP INCORPORATED. IT IS SUBJECT TO CHANGE AND THE CONTROLLING ENGINEERING ORGANIZATION SHOULD BE CONTACTED FOR THE LATEST REVISION.		APPD 16/JAN/95 TERRY L. SHUTTER		DRAWING NO G=63447	
		PRODUCT SPEC 108-2012		SIZE C	
		APPLICATION SPEC 114-2094		CAGE CODE 00779	
		WEIGHT -		SCALE 6:1	
				SHEET 1 OF 1	