

**PRELIMINARY**

spec ref	dr	Hung Ngo	2015/10/16	projection	MM	size	A2	scale	3:1	
tolerance std	eng	Luo Weller	2016/06/14			ecn no	-	rel level	Preliminary	
-	chr	-	-							product family
-	appr	-	-	Amphenol FCI		title	24S + 6HP		rev	2
surface	linear	0.X	±0.5	PwrMAX RAR PRESS-FIT		dwg no	10136993		sheet	1 of 4
ASME Y14.5	angular	0°	±2°	cat. no.		Product - Customer Drw				

Amphenol FCI

© 2016 AFCI

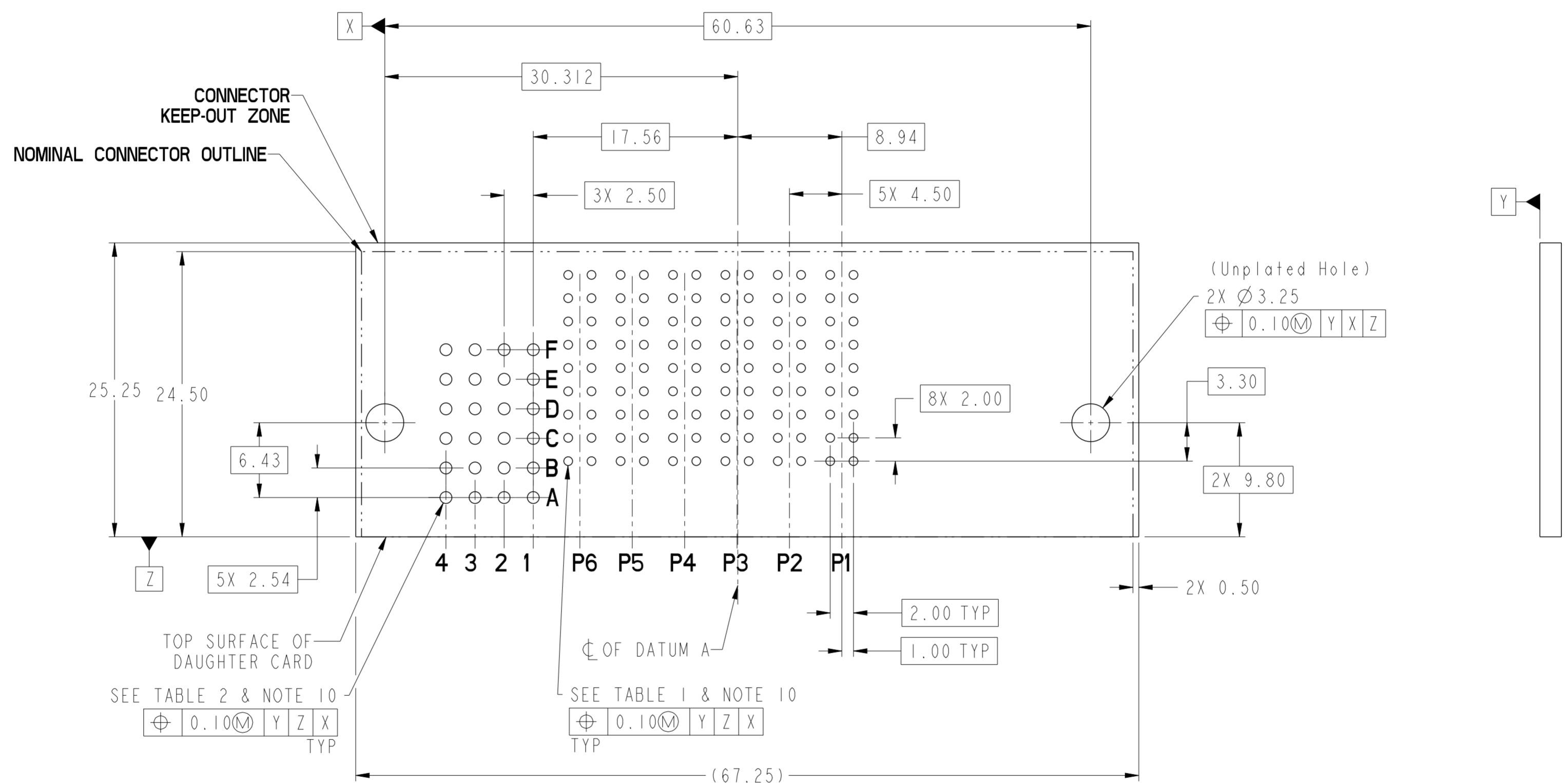

RECOMMENDED PCB LAYOUT  
COMPONENT SIDE  
NOTE 6

Amphenol  
FCi

© 2016 AFci

**PRELIMINARY**



spec ref	dr	Hung Ngo	2015/10/16	projection	MM	size	A2	scale	3:1
tolerance std	eng	Luo Weller	2016/06/14			ecn no	-	rel level	Preliminary
-	chr	-	-						
-	appr	-	-						
surface	linear	0.X	±0.5	<b>Amphenol FCI</b>		title 24S + 6HP PwrMAX RAR PRESS-FIT		dwg no 10136993	rev 2
ASME Y14.5	angular	0°	±2°	cat. no.		-		Product - Customer Drw sheet 2 of 4	

TOP LAYER DESCRIPTION	TABLE 1 (PwrMAX PRESS-FIT POWER PLATED THROUGH-HOLE REQUIREMENTS)							
	DRILLED HOLE DIAMETER	COPPER THICKNESS	TIN-LEAD THICKNESS	NICKEL THICKNESS	GOLD THICKNESS	TIN THICKNESS	SILVER THICKNESS	FINISHED HOLE DIAMETER
TIN-LEAD	0.81-0.86 (0.85 DRILL)	0.025 - 0.050	0.005 - 0.015	-	-	-	-	0.65 - 0.80
IMMERSION TIN	0.81-0.86 (0.85 DRILL)	0.025 - 0.050	-	-	-	0.9 - 1.5um	-	0.70 - 0.80
IMMERSION SILVER	0.81-0.86 (0.85 DRILL)	0.025 - 0.050	-	-	-	-	0.15 - 0.65um	0.70 - 0.80
COPPER (SEE NOTE 9)	0.81-0.86 (0.85 DRILL)	0.025 - 0.050	-	-	-	-	-	0.70 - 0.80
COLD	0.81-0.86 (0.85 DRILL)	0.025 - 0.050	-	0.003 - 0.007	FLASH UP TO 0.0002	-	-	0.69 - 0.80

TOP LAYER DESCRIPTION	TABLE 2 (PwrMAX PRESS-FIT SIGNAL PLATED THROUGH-HOLE REQUIREMENTS)							
	DRILLED HOLE DIAMETER	COPPER THICKNESS	TIN-LEAD THICKNESS	NICKEL THICKNESS	GOLD THICKNESS	TIN THICKNESS	SILVER THICKNESS	FINISHED HOLE DIAMETER
TIN-LEAD	1.125 - 1.175	0.025 - 0.050	0.005 - 0.015	-	-	-	-	0.94 - 1.10
IMMERSION TIN	1.125 - 1.175	0.025 - 0.050	-	-	-	0.9 - 1.5um	-	0.94 - 1.10
IMMERSION SILVER	1.125 - 1.175	0.025 - 0.050	-	-	-	-	0.15 - 0.65um	0.94 - 1.10
COPPER (SEE NOTE 9)	1.125 - 1.175	0.025 - 0.050	-	-	-	-	-	0.94 - 1.10
COLD	1.125 - 1.175	0.025 - 0.050	-	0.003 - 0.007	FLASH UP TO 0.0002	-	-	0.93 - 1.10

Amphenol FCI

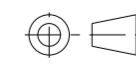
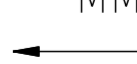
**PRELIMINARY**

spec ref	dr	Hung Ngo	2015/10/16	projection	MM	size	A2	scale	1:1
tolerance std	eng	Luo Weller	2016/06/14			ecn no	-	rel level	Preliminary
-	chr	-	-						
-	appr	-	-	product family	-	-	-	-	-
surface	linear	0.X	±0.5		title 24S + 6HP PwrMAX RAR PRESS-FIT	dwg no 10136993	rev 2	ASME Y14.5	angular 0° ±2°
-		0.XX	±0.25						
-		0.XXX	±0.10						
cat. no.	-		Product - Customer Drw	sheet 3 of 4					

PART NUMBER

10136993-001LF

NOTES:

- 1. CONNECTOR MATERIALS:  
HOUSING: HIGH TEMPERATURE THERMOPLASTIC, BLACK  
UL 94V-0 COMPLIANT  
CONTACTS: HIGH PERFORMANCE COPPER ALLOY
- 2. CONTACT FINISH (GS-12-1314 SECTION 5.2)
- 3. PRODUCT SPECIFICATION: (GS-12-1314).
- 4. APPLICATION SPECIFICATION: (GS-20-0447)
- 5. MANUFACTURER'S NAME, DATE CODE AND OPTIONAL P/N TO APPEAR ON THIS SURFACE. THE P/N CAN BE OMITTED IF THERE IS NOT ENOUGH SPACE ON THIS SURFACE.
- 6. MINIMUM NOMINAL PCB THICKNESS: 1.6mm
- 7. PACKAGED IN TRAYS.
- 8. HOUSING COMPONENT WILL WITHSTAND EXPOSURE TO 260°C PEAK TEMPERATURE FOR 10 SECONDS IN A CONVECTION, INFRA-RED, OR VAPOR PHASE REFLOW OVEN.
- 9. COPPER PLATING THICKNESS IN CENTER OF VIA-HOLE CAN BE NO MORE THAN 0.003 LESS THAN OTHER AREAS.
- 10. ALL HOLE SIZES ARE FINISHED HOLE SIZES.
- 11. A  $\triangle$  SYMBOL WILL BE NEXT TO ANY DIMENSION, VIEW, OR NOTE WHICH HAS BEEN MODIFIED WITH THE CURRENT DRAWING REVISION.
- 12. THE PRODUCT MUST BE USED WITH THE CABLE SIDE PRODUCT TO ALLOW MISALIGNMENT.

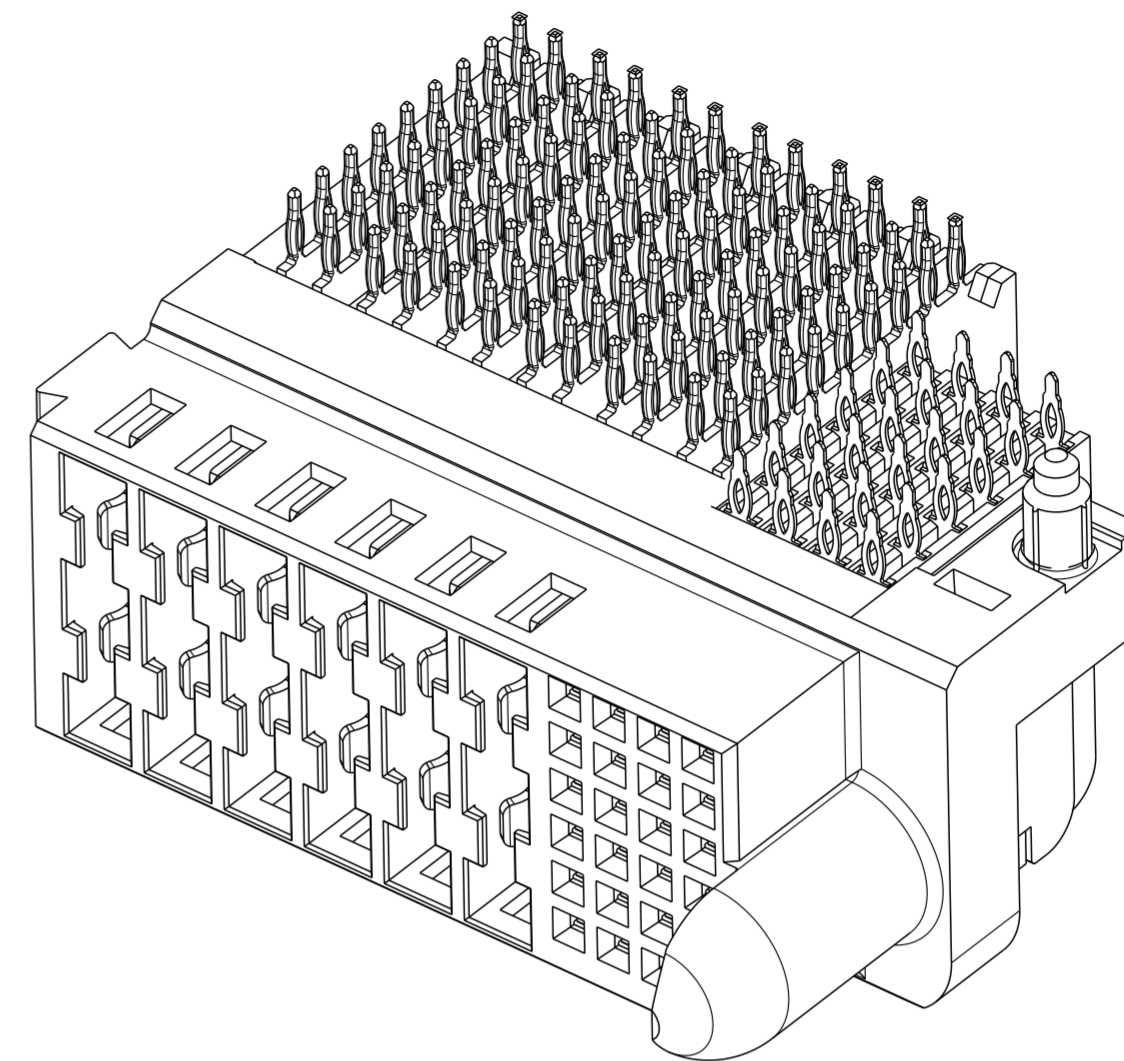

Amphenol  
FCi

PRELIMINARY

spec ref	dr	Hung Ngo	2015/10/16	projection	MM	size	A2	scale	1:1		
tolerance std	eng	Luo Weller	2016/06/14			ecn no	-	rel level	Preliminary		
-	chr	-	-								
-	appr	-	-	product family	PwrMAX	rel level	Preliminary				
surface	linear	0.X	±0.5	<b>Amphenol FCi</b>	title 24S + 6HP PwrMAX RAR PRESS-FIT	dwg no 10136993	rev 2	ASME Y14.5			
		0.XX	±0.25					cat. no.	-	Product - Customer Drw	sheet 4 of 4
	angular	0°	±2°								