

THIS DRAWING IS UNPUBLISHED. RELEASED FOR PUBLICATION, 19  
 © COPYRIGHT 19 BY AMP INCORPORATED. ALL INTERNATIONAL RIGHTS RESERVED.

LOC	DIST	P	F	ZONE	LTR	DESCRIPTION	DATE	APPD
AF	50				V	0B5 -1 PER 0L10-0216-96	5/28/97	JR/JG

- 1 CONTINUOUS STRIP ON REELS.
- 2 FEED TO BE  $.330 \pm .005$ .

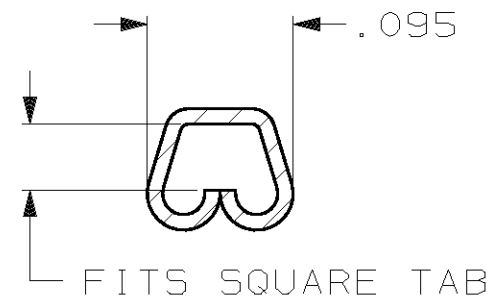
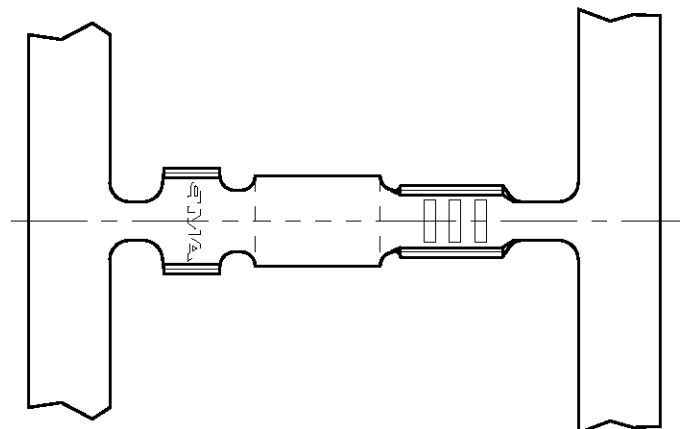

SECTION A-A  
SCALE 8:1

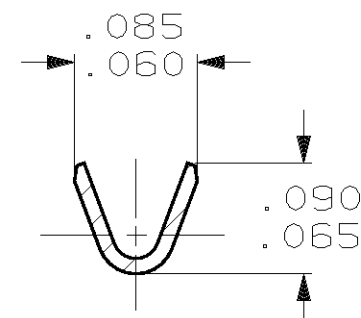
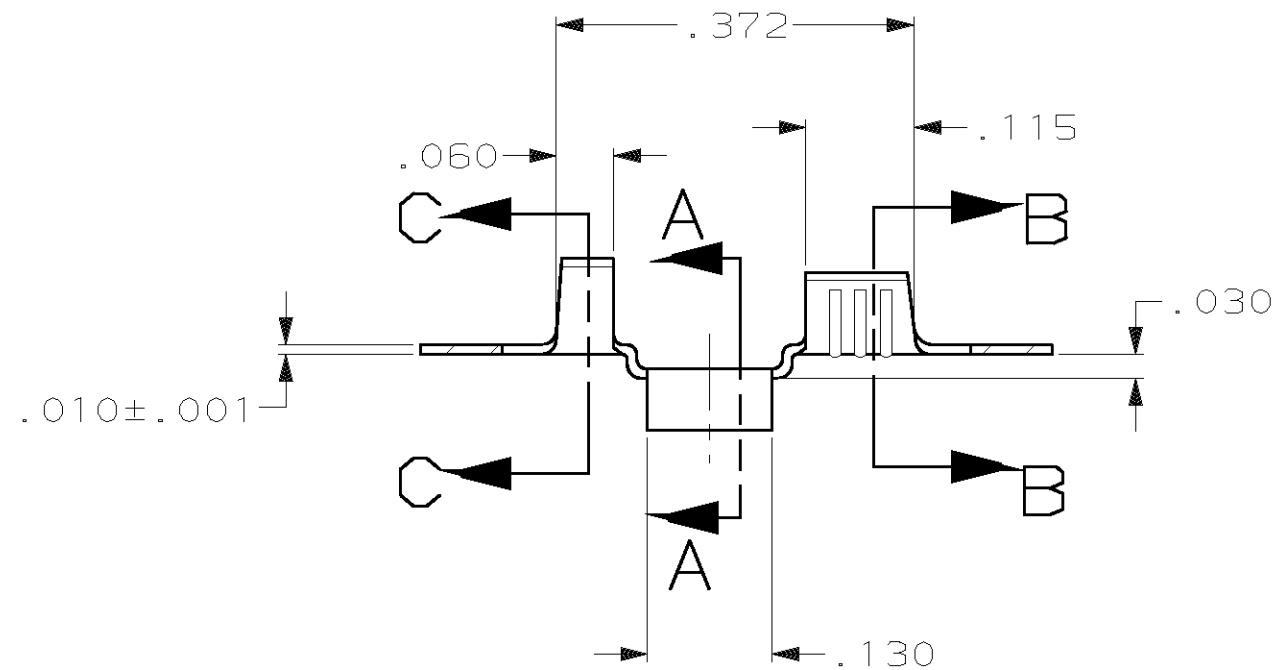

SECTION B-B  
SCALE 8:1

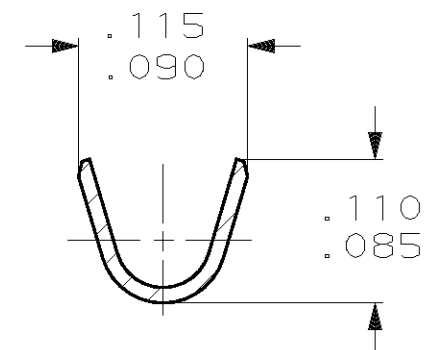

SECTION C-C  
SCALE 8:1

60524-5	.000080 MIN TIN	H04 BE COPPER	<del>60524-4</del>
<del>60524-8</del>	GOLD OVER NICKEL	H04 BRASS	<del>60524-3</del>
<del>60524-6</del>	.000080 MIN TIN	H04 BRASS	<del>60524-2</del>
<del>60524-7</del>	-	H04 BRASS	<del>60524-1</del>
REVERSE REEL PART NO.	FINISH	MATERIAL	PART NO
DO NOT SCALE PRINT. UNLESS SPECIFIED DIMENSIONS IN mm [INCHES] TOLERANCES ON: 2 PLC DEC ± - 3 PLC DEC ± .015 ANGLES ± -	DR 1/9/95 JR RUTH	<b>AMP</b> AMP Incorporated Harrisburg, PA 17105-3608	NAME RECEPTACLE, TAB, WRAP TYPE
	CHK 1/9/95 MS FEHER		
	APPD 1/9/95 J GILLESPIE		
	APPD 1/9/95 R REINER		
MATERIAL SEE TABLE	PRODUCT SPEC -	SIZE B	CAGE CODE 00779
FINISH SEE TABLE	APPLICATION SPEC -	DRAWING NO C-60524	SCALE 5:1
	WEIGHT -	SHEET 1 OF 1	

THIS DRAWING IS A CONTROLLED DOCUMENT FOR AMP INCORPORATED. IT IS SUBJECT TO CHANGE AND THE CONTROLLING ENGINEERING ORGANIZATION SHOULD BE CONTACTED FOR THE LATEST REVISION.