

COUNT	DESCRIPTION OF REVISIONS	BY	CHKD	DATE	COUNT	DESCRIPTION OF REVISIONS	BY	CHKD	DATE
△					△				
△					△				
△					△				

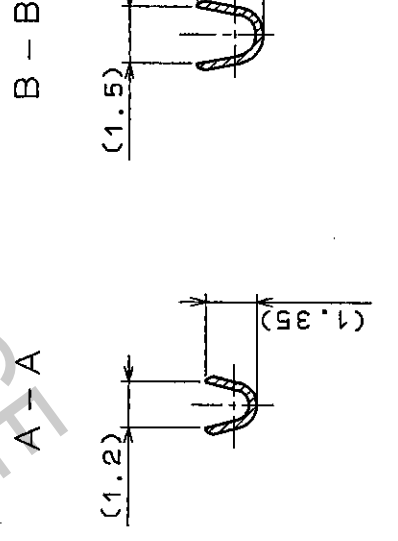
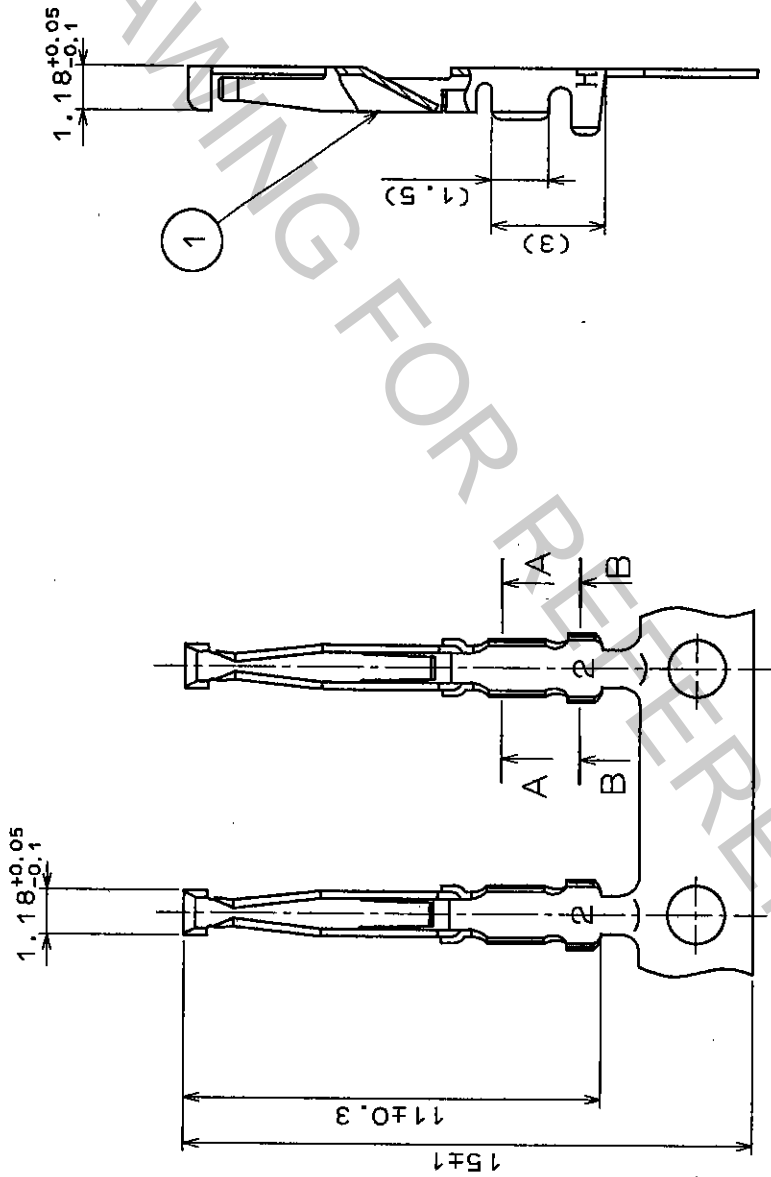
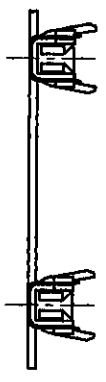
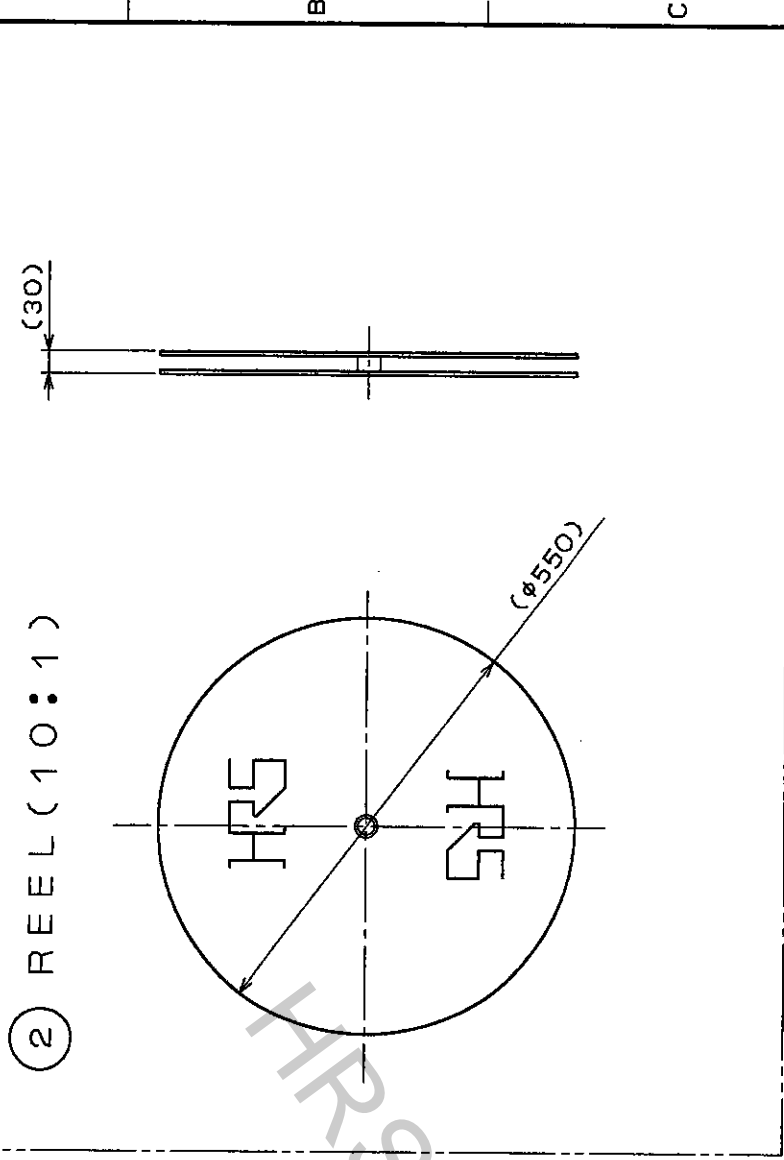

NOTE 1 APPLICABLE WIRE
 : AWG#24~30(INSULATION DIA 1.15 MAX).
 2 CRIMPING CONDITION AS CRIMP HEIGHT IS
 SPECIFIED INDIVIDUALLY DEPENDING ON
 WIRE USED.

NO.	PHOSPHOR BRONZE MATERIAL	SILVER PLATING(N=10000) FINISH . REMARKS	2	CARTON (REEL)	FINISH . REMARKS
CODE NO. (OLD)			NO.	MATERIAL	CHECKED
			DESIGNED		APPROVED
			DRAWN		RELEASED
			H. Kawaguchi	H. Kishi	M. Ojishima
			96.8.22	96.8.23	96.8.29
DRAWING NO. EDC3-021032		PART NO. RP19-SC-222			
SCALE 5:1		CODE NO. CL113-0266-2			
UNITS mm		HIROSE ELECTRIC CO., LTD.			
		FORM NO. 229			

TO	
R	