

REV.	ECN NO.	REVISIONS	DRN.	CKD.	APP.	DATE
D		REDRAWN IN PRO/E FORMAT ADDED BI-COLOR PAD LAYOUT	ADM			

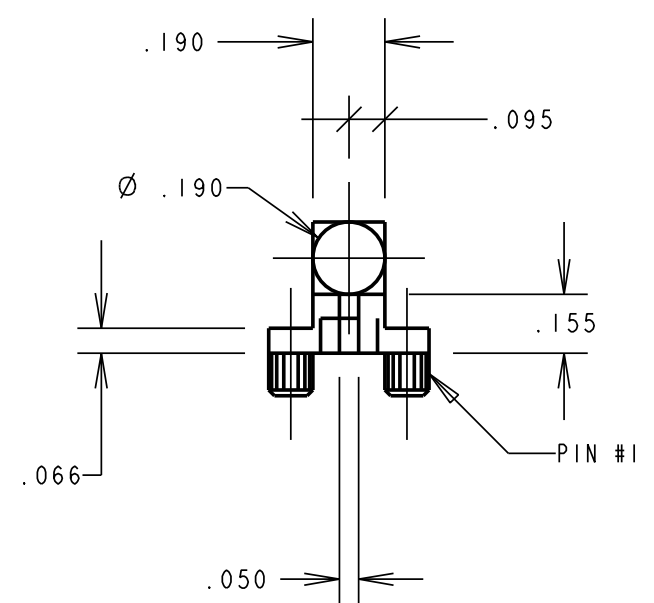
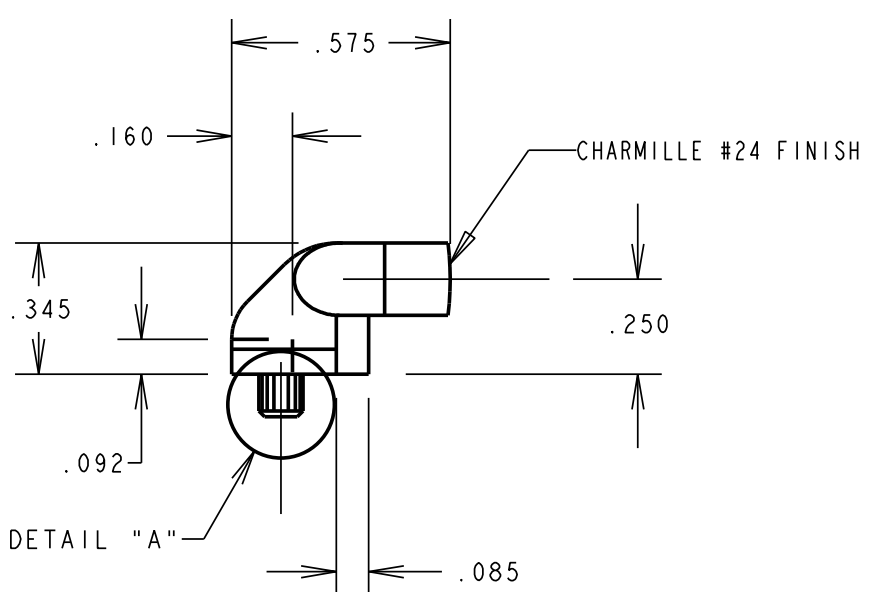
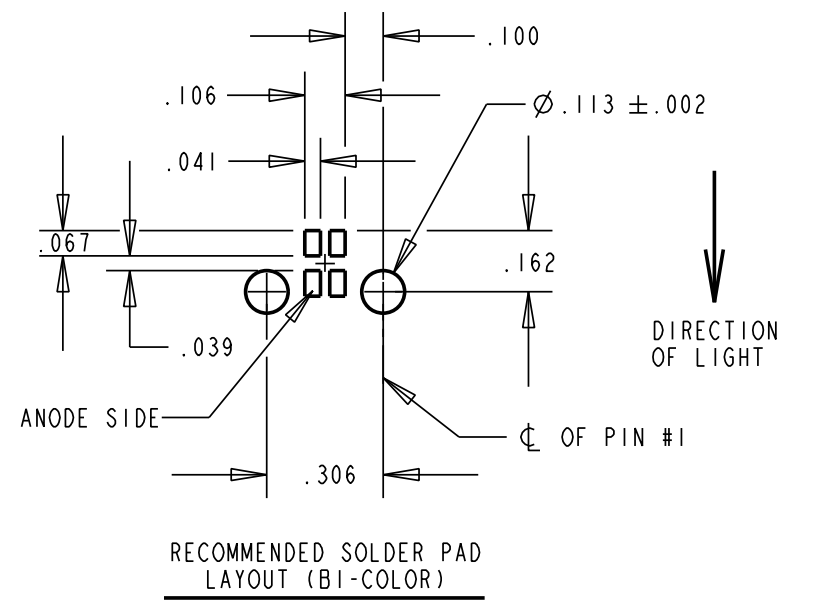
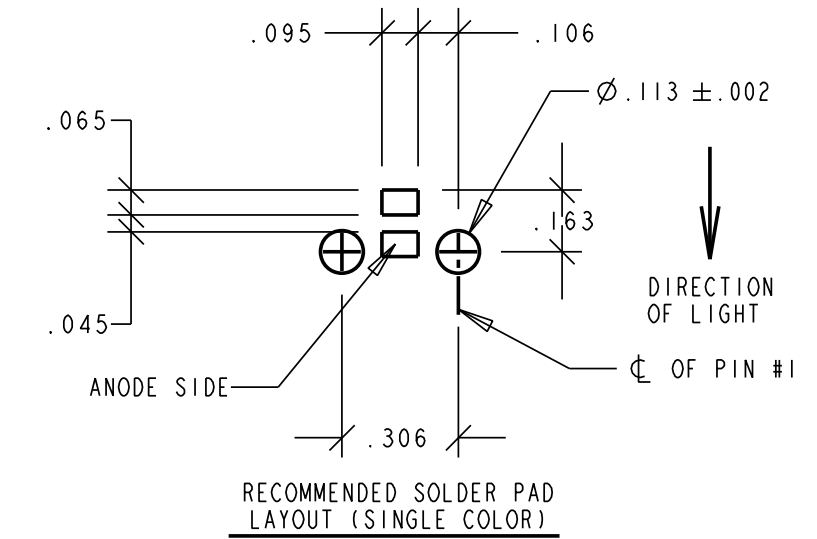
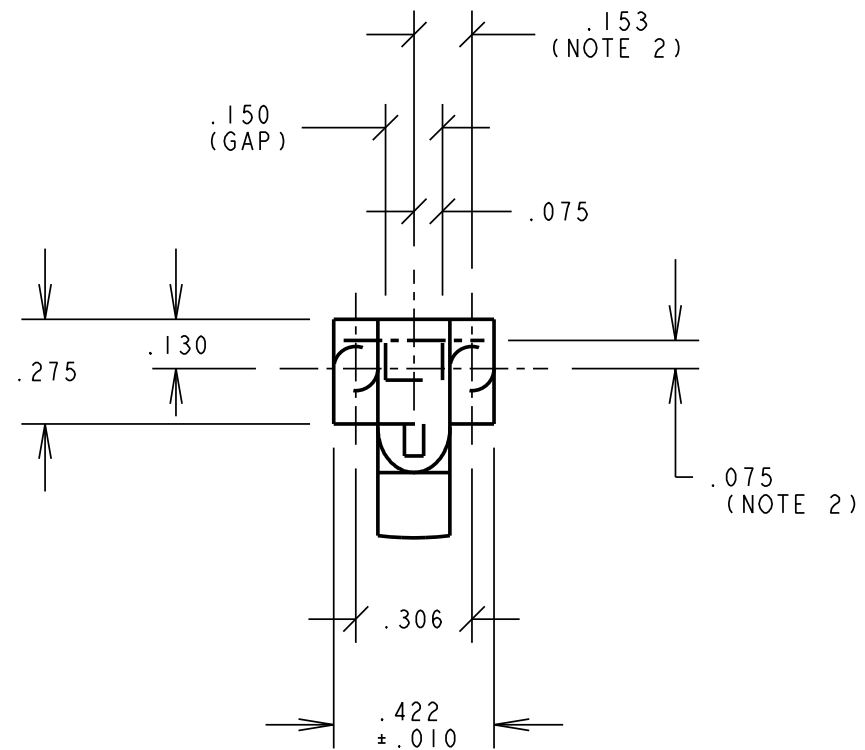
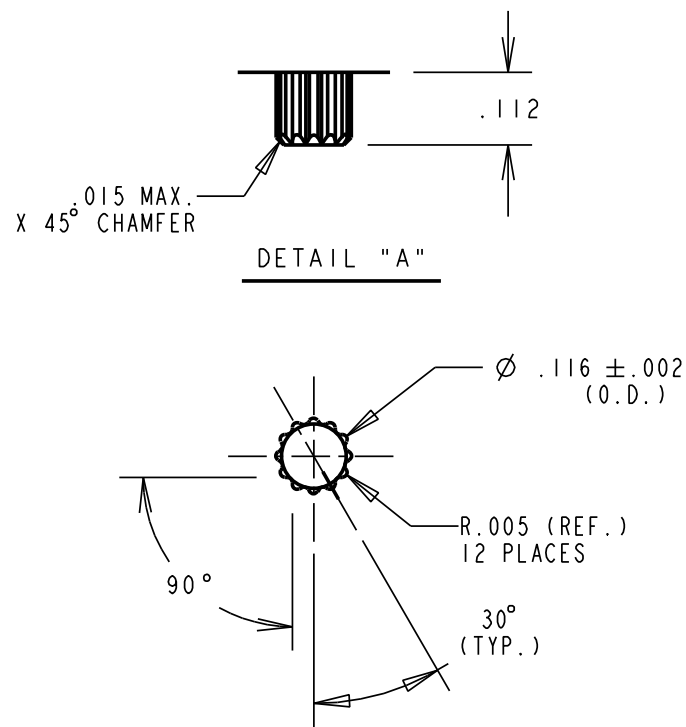

- NOTES:
 1. COMPONENT TO BE MOLDED IN A WATER CLEAR TRANSMISSIVE POLYCARBONATE.
 2. RECOMMENDED C.L. PLACEMENT OF LED.
 3. REFER TO DIALIGHT P/N: 515-1011.

THIS DRAWING AND THE CONTENTS HEREIN ARE CONFIDENTIAL AND THE SOLE PROPERTY OF DIALIGHT. REPRODUCTION OF THIS DRAWING OR CONSTRUCTION OF ANY PARTS WITHIN THIS DRAWING ARE FORBIDDEN WITHOUT THE WRITTEN CONSENT OF DIALIGHT.		
SCALE: DRAWING SCALE ALL DIM'S IN: INCHES (MM)	DRAWING NUMBER C-15754	REV D
TOLERANCES: UNLESS OTHERWISE SPECIFIED FRACTIONS: ±1/64 DECIMALS (.XX): ±.01 DECIMALS (.XXX): ±.005 DECIMALS (.XXXX): ±.0005 ANGLES: ±1°	TITLE LED, SINGLE LIGHTPIPE	
FINISH:	MATERIAL	
FSCM 83330	Dialight	1501 ROUTE 34 SOUTH FARMINGDALE, NJ 07727
	SHEET OF	FAMILY TABLE: