

37536-82		REVISIONS		
ZONE	LTR	DESCRIPTION	DATE	APPROVED
	B	(MFG) REDRAWN, SAME SIZE, STANDARDIZED, ECN: 59525-143	3-8-78 COLON	<i>Hand</i>
✓	C	(MFG) ADDED 4 REL -8 & DATA ECN: 70500-17	10-26-78 LONGWELL	<i>JJS</i>
	D	(CL ID) SEE CHG NOTICE ECN: 25778	10/28/91 11/11/90tt	<i>P</i>

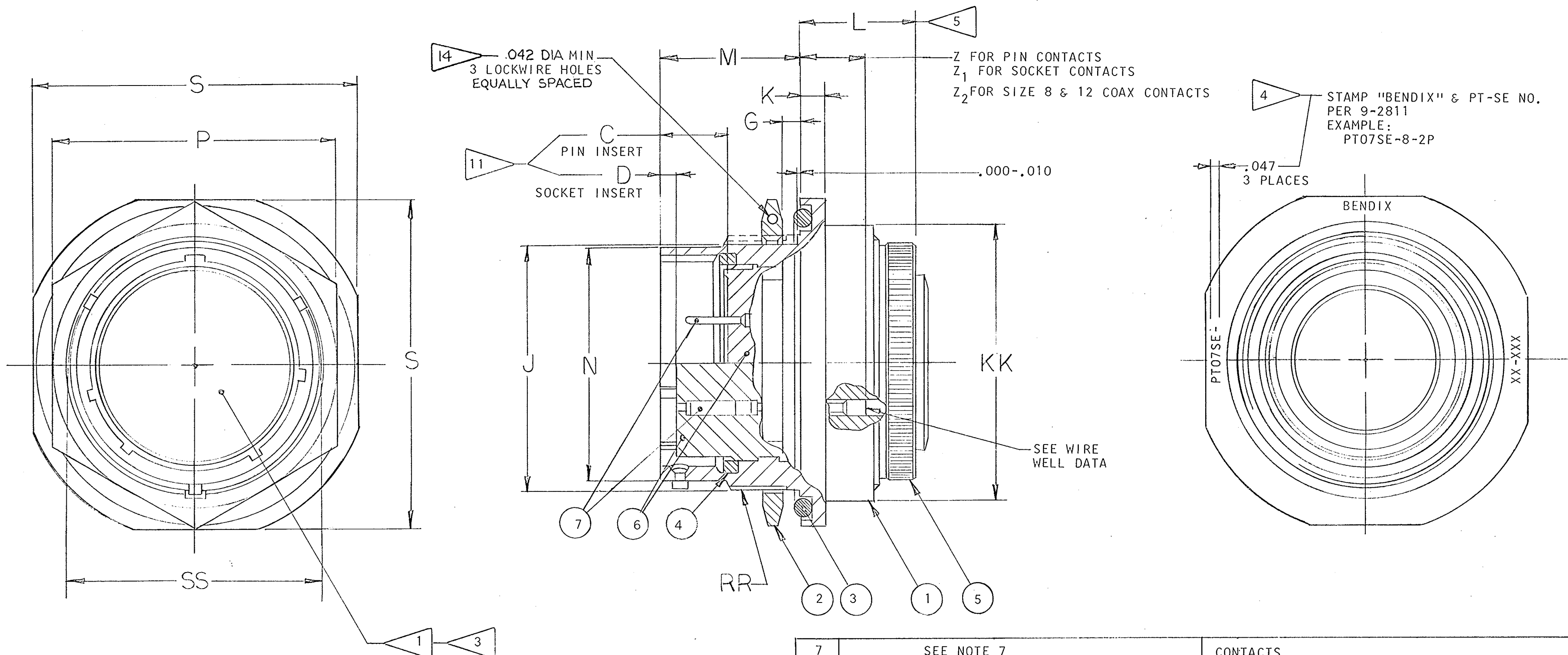

FIND NO.	QTY REQD	CODE IDENT	PART NUMBER	DESCRIPTION	NOTE REF
7			SEE NOTE 7	CONTACTS	7
6	1		10-330806-( )P/50-( )P OR 10-330806-( )S/50-( )S	INSERT, PIN INSERT, SOCKET	7
5	1		10-330957-XX3	CLAMPING NUT	
4	1		10-330914-XX1	GASKET	
3	1		SEE COLUMN	PACKING	13
2	1		10-123017-XX3	NUT	
1	1		10-330923-XX3	SHELL	

UNLESS OTHERWISE SPECIFIED		SIGNATURES		DATES		The Bendix Corporation Electrical Components Division Sidney, New York	
LINEAR DIMENSIONS ARE IN INCHES. TOLERANCES: .XXX ± .010, .XX ± .03, .X ± .1, ANGLES ± 2°. OTHER STANDARDS PER 9-3800 AND MIL-D-1000. NOTE REF		PREPARED	A. NILES	2-16-61	TITLE: CONNECTOR, ELECTRICAL RECEPTACLE, TYPE PT-SE( ) JFW, OLIVE DRAB		
		CHECKED	B. Tomco	3-28-78			
		APPROVED	<i>[Signature]</i>	3-9-78			
		APPROVED	<i>[Signature]</i>	3-30-73			
MATERIAL SPEC	PROCESS SPEC TEST 9-4039-1 ASSY 9-3836-2 9-2437-1 9-2811			SIZE C		CODE IDENT NO. 77820	71-331706 THRU 71-331750
				SCALE NONE	WT	REF 71-196706/50	SHEET 1 OF 2

SEE SHEET 2.  
NOTES:

NEXT ASSEMBLY

USE OF THIS DOCUMENT IS UNLIMITED. DOCUMENTS REFERENCED HEREON CONTAIN LIMITED RIGHTS DATA.

SCANNED [71-331706/50] A

ASSEMBLY NUMBER	PT-SE NO.	PACKING	C		D		PANEL MIN	THK MAX	J FLAT		K	L	M	N DIA		P HEX	S	Z	Z <sub>1</sub>	Z <sub>2</sub>	RR		SS	
			+.000	+.000	+.000	+.011			MAX	±.005				+.001	+.017						MAX	MAX	MAX	+.011
71-331706-()	07SE- 6-()	NOT AVAILABLE																						
71-331708-()	- 8-()	10-90351-17	.332	.025	.062	.125	.530	.125	.734	.696	.473	.750	.938	.323	.262	.422	.719	.5625-24	UNEF				.563	
71-331710-()	-10-()	10-90351- 19	.332	.025	.062	.125	.655	.125	.734	.696	.590	.875	1.062	.323	.262	.422	.844	.6875-24	UNEF				.680	
71-331712-()	-12-()	- 22								.818							.969	.875 -20					.859	
71-331714-()	-14-()	- 24								.942							1.094	1.000 -20					.984	
71-331716-()	-16-()	- 26								1.066							1.219	1.125 -18					1.108	
71-331718-()	-18-()	- 28								1.191							1.344	1.250 -18					1.233	
71-331720-()	-20-()	-128	.394	.087		.250	1.316	.156		.884	1.250	1.562	1.812	.197	.136	.266	1.500	1.375 -18					1.358	
71-331722-()	-22-()	-130					1.441			.884	1.375	1.688	1.938	.197	.135	.266	1.625	1.500 -18					1.483	
71-331724-()	-24-()	-132					1.566		.766	.917	1.500	1.812	2.062	.164	.103	.235	1.750	1.625 -18					1.610	

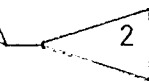

**ACCESSORIES**  
(NOT PART OF STANDARD ASSEMBLY)

SEE DRAWING  
10-150000

COAXIAL DATA  
SEE NOTE 1

WIRE WELL DATA				
CONTACT SIZE	20	16	12	12 FOR #10 WIRE
CONDUCTOR WELL DIA	.048 <sup>+</sup> .002 -.000	.066 <sup>+</sup> .002 -.000	.100±.002	.136±.002
CONDUCTOR WELL DEPTH	.189 <sup>+</sup> .037 -.000	.250 <sup>+</sup> .031 -.000	.250 <sup>+</sup> .031 -.000	.250 <sup>+</sup> .031 -.000
INSULATION WELL DIA	.091 <sup>+</sup> .002 -.000	NOT APPLICABLE	NOT APPLICABLE	NOT APPLICABLE
INSULATION WELL DEPTH	.072 <sup>+</sup> .006 -.000	NOT APPLICABLE	NOT APPLICABLE	NOT APPLICABLE

- 7. SEE SEPARATE PARTS LIST FOR COMPONENT PART NUMBERS AND QUANTITIES.
  - 6. SEE DRAWING 71-331606/50 & OTHERS FOR REQUIRED MATING PLUG ASSEMBLY.
  - 5. DIMENSION INDICATES FINAL INSTALLATION. FOR STORAGE & SHIPPING, SHELL & CLAMP ASSEMBLY MUST BE LOOSELY COUPLED.
  - 4. SEE WORK ORDER FOR PERMISSIBLE ADDITIONAL OR ALTERNATE STAMPING.
  - 3. INSERT ASSEMBLIES ARE NOT REMOVABLE.
  - 2. TO COMPLETE ASSEMBLY NO. & PT-SE NO., ADD APPLICABLE INSERT ARRANGEMENT SUFFIX TO BASE NUMBERS LISTED ABOVE PER 9-2437-1.
  - 1. FOR CONTACT ARRANGEMENTS & COAXIAL DATA, SEE DWGS L-15206-() THRU L-15250-().
- 14. FORMED LOCKWIRE HOLE DESIGN (G HOLES) OPTIONAL.
  - 13. FOR MAXIMUM SEALING EFFICIENCY, APPLY LIGHT COAT OF MIL-S-8660 TO PACKING.
  - 12. UNITS ILLUSTRATED MEET THE MATERIAL & FINISH REQUIREMENTS OF MIL-C-26482.
  - 11. INSERT LOCATING DIMENSIONS APPLY BEFORE ASSEMBLY OF CONTACTS.
  - 10. SEE INDIVIDUAL DRAWINGS FOR 71-331714-22, 71-331714-91 AND 71-331718-91.
  - 9. ALL INSERT HOLES MUST HAVE CONTACTS ASSEMBLED AND ALL UNUSED GROMMET HOLES MUST BE FILLED WITH THE APPROPRIATE SIZE SEALING PLUG 10-101033.
  - 8. PACKAGE PER PRODUCTION PROCESS SHEET.

SIZE	CODE IDENT NO.	71-331706 THRU 71-331750	
C	77820		
SCALE	WT	REF	SHEET 2

REV SYM	B	C	D								
---------	---	---	---	--	--	--	--	--	--	--	--

NOTES:

71-331706/50